

LPS Screen

Lightweight Climbing Enclosure

Instructions for Assembly and Use – Standard Configuration – Issue 04 | 2018

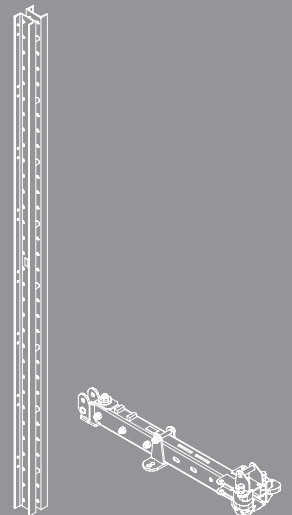
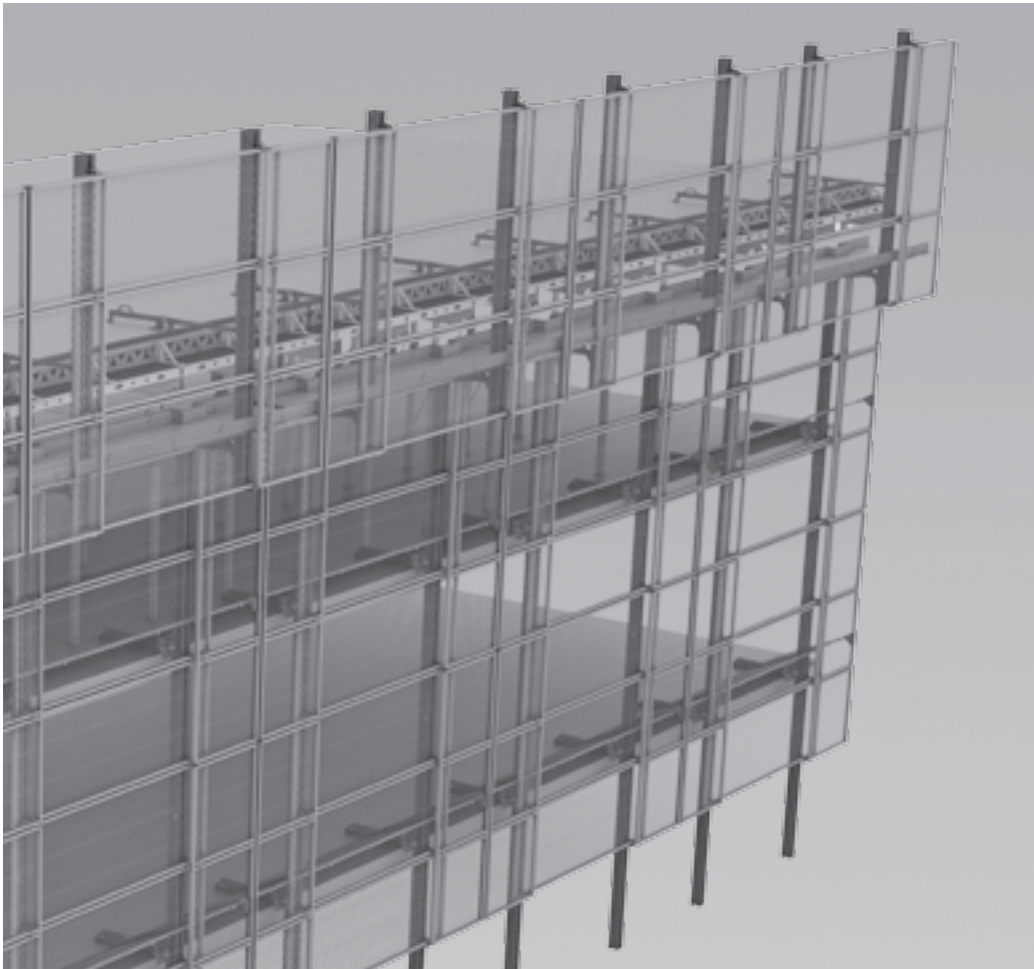

Main Components

Version 1

Climbing Protection Panel with straight protection screen.

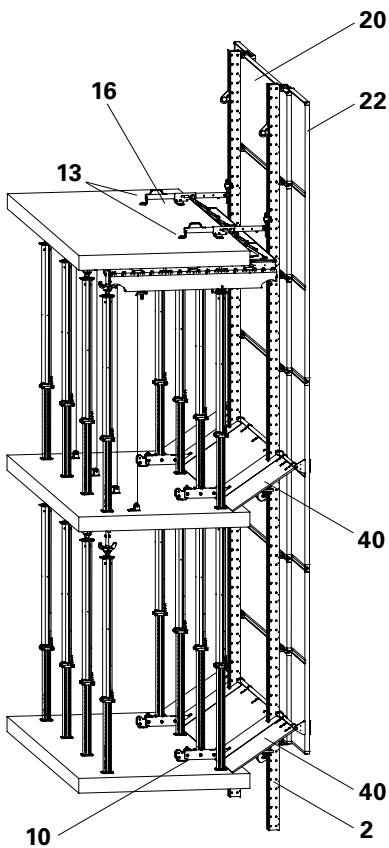

Version 2

Climbing Protection Panel with working platform.

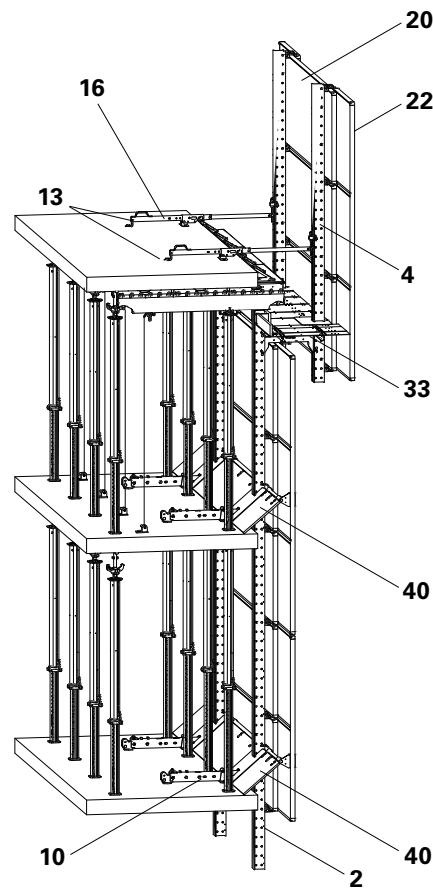

- 2 Climbing Profile (Climbing Rail-2 LPS 748 or 998)
- 4 Enclosure Post (Climbing Rail LPS 398)
- 10 Slab Shoe LPS, adjustable
- 13 Anchoring M24
- 16 Slab Anchor Template-2 LPS
- 20 Mesh Enclosure
- 22 Telescopic Screen
- 33 Platform LPS
- 40 Hinged Cover

Overview

Main Components	3
Key	4
Presentational Reference	4

Introduction

Target Groups	5
Additional Technical Documentation	5
Intended Use	6
Instructions on Use	6
Cleaning and Maintenance Instructions	7

Safety Instructions

Cross-System	8
System-Specific	10
Storage and Transportation	11
Component Overview and Tool List	12
Tightening Torque	13

General

A1 System Overview	14
Climbing Enclosure	14
A2 Climbing Device and Hydraulics	16
A3 Operating Status and Loads	18
A4 Operating Sequence	20

Work Preparation

B1 Planning the Supporting Structure	24
System Dimensions	24
Dependence on Storey Heights	26
Climbing Rail Spacings	30
Additional Spacers	31
Suspension with the Slab Shoe	32
Mixed Suspension	36
Suspension for Corner Area	37
Reaction Forces	38
B2 Planning the Units	40
General	40
Attachment Point for the Crane	40
Platform Cantilever Beam and Platform Decking	42
Platform Extension	44
Protection against Falling Objects	47
Covering with the Finishing Platform Enclosure	52
Vertical Bracing	55
B3 Corner Platforms	56
External Corners	56
Internal Corners	60
Non-Rectangular Building Corners	62
B4 Special Applications	64
Units on Circular Structures	64
Anchoring to Columns	65
Variants	66
Additional Finishing Platforms	67

Assembly

C1 Pre-Assembly	68
General	68

Preparation of the Climbing Rails	68
Assembly of the Attachment Points	69
Assembly of the Rail Connector SRU/LPS	70
Assembly of the Rail Connector LPS Platform LPS	71
Assembly of the Enclosure Post	74
Assembly of the Cover Flaps	75
Assembly of the Finishing Platform	77
Assembly of the Screen and Telescopic Screen	78
C2 On-Site Assembly	87
Assembly of the Platform Extension	87
Telescoping the Screen	88
Assembly of the Telescopic Screen on the Front Side of the Platform	89
Gap Covering with Draw-in Profiles	91
Gap Covering with Cover Strip Rubbers	93
C3 Suspension on the Structure	94
Setting Up the Climbing Unit	94
Assembly of the Climbing Unit	96
Troubleshooting	103

Utilisation

D1 Suspension and Anchoring	104
Fixing the Leading Anchor	104
Assembly of Slab Shoe LPS	108
Dismantling Slab Shoe LPS	109
Removing the Anchoring	110
D2 Operating the Slab Shoe	112
Opening / Closing the Rail Guidance	112
Activating / Deactivating the Climbing Pawl	113
Height Adjustment of the Slab Shoe	114
D3 Horizontal Bracing	115
Vertical Bracing	115
D4 Moving by Crane	116
Safety Instructions	116
Preparations	117
Moving Procedure	118
Troubleshooting	119
Finishing Tasks	119
D5 Moving with the Climbing Device	120
Safety Instructions	120
Initial Operation of the Climbing Hydraulics	121
Preparations	121
Hydraulic Diagram	121
Remedial Measures for Malfunctions	121
Moving Procedure	122
Self-Climbing Procedure	123
Bleeding the Oil-Hydraulic System	129

Dismantling

Removing the Climbing Unit	130
Dismantling the Climbing Unit	132

Components

LPS Screen	134
------------	-----

Key

Pictogram | Definition



Danger / Warning / Caution



Information



To be complied with



Load-bearing point



Visual check



Tip



Personal protective equipment to prevent falling from a height (PPE)



Misapplication

Arrows



Arrow representing an action



Arrow representing a reaction of an action*



Forces

* If not identical to the action arrow.

Safety instruction categories

The safety instructions alert site personnel to the risks involved and provide information on how to avoid these risks. Safety instructions are featured at the beginning of the section or ahead of the instructions, and are highlighted as follows:



Danger

This sign indicates an extremely hazardous situation which, if not avoided, will result in death or serious injury.



Warning

This sign indicates a hazardous situation which, if not avoided, could result in death or serious injury.



Caution

This sign indicates a hazardous situation which, if not avoided, could result in minor or moderate injury.



Information

This sign indicates situations whereby failure to observe the information can result in material damage.

Structure of the safety instructions



Signal word

Type and source of the danger!
Consequences of non-compliance.
⇒ Avoidance measures.

Dimension specifications

Dimensions are usually given in cm. Other measurement units, e.g. m, are shown in the illustrations.

Conventions

- Instructions are numbered with:
1., 2., 3.
- The result of an instruction is shown by: →
- Position numbers are clearly provided for the individual components and are given in the drawing, e.g. **1**, in the text in brackets, for example (1).
- Multiple position numbers, i.e. alternative components, are represented with a slash: e.g. **1 / 2**.

Presentational Reference

The illustration on the front cover of these instructions is understood to be a system representation only. The assembly steps presented in these Instructions for Assembly and Use are shown in the form of examples with only one component size. They are valid accordingly for all component sizes contained in the standard configuration.

For a better understanding, detailed illustrations are partly incomplete. Safety installations may not have been included in these detailed drawings, but must be used nevertheless.

Target Groups

Contractors

These Instructions for Assembly and Use are designed for contractors who use the PERI climbing system either for

- assembling, modifying and dismantling purposes, or
- use it or
- have it used for formwork operations.

Competent person

(Construction Site Coordinator)

The Safety and Health Protection Coordinator*

- is appointed by the client,
- must identify potential hazards during the planning phase,
- determines measures that provide protection against risks,
- creates a safety and health plan,
- coordinates the protective measures for the contractor and site personnel so that they do not endanger each other,
- monitors compliance with the protective measures.

Competent person qualified to carry out inspections

Due to the specialist knowledge gained from professional training, work experience and recent professional activity, the competent person qualified to carry out inspections has a reliable understanding of safety-related issues and can carry out inspections correctly. Depending on the complexity of the test to be undertaken, e.g. scope of testing, type of testing or the use of a certain measuring device, a range of specialist knowledge is necessary.

Qualified persons

The PERI climbing system may only be assembled, modified or dismantled by personnel who are suitably qualified to do so. For the work to be carried out, the qualified persons must have received instructions** covering at least the following points:

- Explanation of the plan for the assembly, modification or dismantling of the climbing system in an understandable form and language.

- Description of measures in order to safely assemble, modify or dismantle the climbing system.
- Designation of the preventive measures to avoid the risk of persons and objects falling.
- Designation of the safety precautions in the event of changing weather conditions that could adversely affect the safety of the formwork system as well as the persons concerned.
- Details regarding the permissible loads.
- Description of any other risks that are associated with the assembly, modification or dismantling procedures.



- **In other countries, ensure that the relevant national guidelines and regulations in the respective current version are complied with!**
- **If no country-specific regulations are available, it is recommended to proceed according to German guidelines and regulations.**
- **A competent person must be present on site during assembly operations.**

* Valid in Germany: Regulations for Occupational Health and Safety on Construction Sites 30 (RAB 30).

** Instructions are given by the contractor himself or a competent person selected by him.

Additional Technical Documentation

- Instructions for Use:
 - LPS Climbing Device and Hydraulics
 - Crane Eye BR-2 2.5 t
 - Screen Adapter Stacking LPS 60
 - Concrete Cones
- Data Sheet: Anchor Bolt PERI 14/20 x 130
- Flyer LPS Screen

Intended Use

Product description

PERI products have been designed for exclusive use in the industrial and commercial sectors by qualified personnel only.

These Instructions for Assembly and Use describe the standard assembly of the Rail Climbing System LPS as a Climbing Protection Panel.

The Climbing Protection Panel may only be used for the application shown here as a protection against falling with partial wind protection in the interior and as protection against falling objects. Version 2 also offers a working platform for accessing the slab edge.

The climbing procedure can be carried out with both versions either by crane or using the hydraulic climbing device.

Features

The LPS Screen Climbing Enclosure is a standard application of the LPS Light Protection System from PERI.

LPS Screen is a bracket-type supporting structure and has been designed as protection scaffold according to DIN EN 12811 and DIN 4420. Wind load assumptions are assumed in accordance with DIN EN 1991-1 (EC 1).

The supporting structure basically consists of 2 bracket structures that are connected to each other by an enclosure.

The enclosure consists of LPS Mesh Panels and is fixed to the Climbing Rails or Steel Walers SRU over the entire height by means of clamp connectors.

The mesh panels can be variably extended laterally with telescopic screen elements.

The lower Climbing Rail LPS is anchored in the floor slabs of the structure by means of slab shoes.

Version 1 with straight protection screen:

The LPS Climbing Rail forms the bracket structure.

Version 2 with working platform:

The bracket structure consists of a bottom Climbing Rail LPS to which a platform cantilever beam is bolted and a further post (shorter climbing rail) is attached.

The upper post is, thus, offset by the width of the platform and supports the enclosure which is projecting upwards. A platform consisting of platform beams and decking elements made of anti-slip checker plate is attached to the Platform Cantilever Beam.

Instructions on Use

Use in a way not intended according to the Instructions for Assembly and Use, or any use deviating from the standard configuration or the intended use, represents a misapplication with a potential safety risk, e.g. risk of falling.

Only PERI original parts may be used. The use of other products and spare parts is not allowed.

Changes to PERI components are not permitted.

Cleaning and Maintenance Instructions

In order to maintain the value and operational readiness over the long term, clean the components after every use. Some repair work may also be inevitable due to the tough working conditions. The following points should help to keep cleaning and maintenance costs as low as possible.

For cleaning and maintenance of the hydraulic system, observe the Instructions for Use for the LPS Climbing Device and Hydraulics.

Remove concrete residue with water immediately after concreting; this avoids any time-consuming and costly cleaning operations.

Never clean powder-coated components, e.g. elements and accessories, with a steel brush or hard metal scraper; this ensures that the powder-coating remains intact.

Mechanical components, e.g. spindles or gear mechanisms, must be cleaned of dirt or concrete residue before and after use, and then greased with a suitable lubricant.

Provide suitable support for the components during cleaning so that no unintentional change in their position is possible.

Do not clean components suspended on crane slings.

Cross-System

General

The contractor must ensure that the Instructions for Assembly and Use supplied by PERI are available at all times and understood by the site personnel.

These Instructions for Assembly and Use can be used as the basis for creating a risk assessment. The risk assessment is compiled by the contractor. These Instructions for Assembly and Use do not replace the risk assessment!

Always take into consideration and comply with the safety instructions and permissible loads.

For the application and inspection of PERI products, the current safety regulations and guidelines valid in the respective countries must be observed.

Materials and working areas are to be inspected on a regular basis, especially before each use and assembly, for:

- signs of damage,
- stability and
- function.

Damaged components must be exchanged immediately on site and may no longer be used.

Safety components are to be removed only when they are no longer required.

Components provided by the contractor must conform with the characteristics required in these Instructions for Assembly and Use, as well as all valid construction guidelines and standards. Unless otherwise indicated, this applies in particular to:

- Timber components: Strength Class C24 for Solid Wood according to EN 338.
- Scaffold tubes: galvanised steel tubes with minimum dimensions of $\varnothing 48.3 \times 3.2$ mm according to EN 12811-1:2003 4.2.1.2.
- Scaffold tube couplings according to EN 74.

Deviations from the standard configuration are only permitted after a further risk assessment has been carried out by the contractor.

On the basis of this risk assessment, appropriate measures for working and operational safety as well as stability are to be determined.

Corresponding proof of stability can be provided by PERI on request if the risk assessment and resulting measures to be implemented are made available.

Before and after exceptional occurrences that may have had an adverse effect regarding the safety of the slab props, the contractor must immediately

- create another risk assessment, with appropriate measures for ensuring the stability of the climbing enclosure being carried out based on the results.
- arrange for an extraordinary inspection to be carried out by a competent person qualified to do so. The aim of this inspection is to identify and rectify any damage in good time, in order to guarantee the safe use of the climbing enclosure.

Exceptional occurrences can include:

- accidents,
- longer periods of non-use,
- natural events, e.g. heavy rainfall, icing, heavy snowfall, storms or earthquakes.
- Fire.

Assembly, modification and dismantling work

Assembly, modification or dismantling of climbing enclosures may only be carried out by qualified persons under the supervision of a competent person. The qualified persons must have received appropriate training for the work to be carried out with regard to specific risks and dangers.

On the basis of the risk assessment and Instructions for Assembly and Use, the contractor must create installation instructions, in order to ensure safe assembly, modification and dismantling of the climbing enclosure.

The contractor must ensure that the personal protective equipment required for the assembly, modification or dismantling of the climbing enclosure, e.g.

- safety helmet,
- safety shoes,
- safety gloves,
- safety glasses,

is available and used as intended.

If personal protective equipment against falling from a height (PPE) is required or specified in local regulations, the contractor must determine appropriate attachment points on the basis of the risk assessment.

The contractor stipulates the PPE to be used to prevent falling.

The contractor must

- provide safe working areas for site personnel, which are to be reached through the provision of safe access ways. Areas of risk must be cordoned off and clearly marked.
- ensure the stability during all stages of construction, in particular during assembly, modification and dismantling operations.
- ensure and prove that all loads can be safely transferred.

Utilisation

Every contractor who uses or allows the climbing enclosure to be used, has the responsibility for ensuring that the equipment is in good condition.

If the climbing enclosure is used successively or at the same time by several contractors, the health and safety coordinator must point out any possible mutual hazards, and all work must be then coordinated.

System-Specific

Assembly work

The contractor must ensure that the user has the appropriate and sufficient number of tools, lifting equipment and slings, suitable and sufficient space for assembly and storage, as well as adequate crane capacity at his disposal.

There is always the possibility of unforeseen risks arising during assembly work. The level of risk is to be estimated according to each individual case and, if necessary, measures are to be taken to avoid or at least to minimise the risk.

If guardrails cannot be used due to technical reasons or have to be removed, the area of risk must be cordoned off and all personnel working on the slab edges must be secured using other means, e.g. personal protective equipment to prevent falling from a height (PPE).

Use a guide rope to ensure that assembly units suspended from the crane are fully under control when being moved. Persons are not allowed to remain under suspended loads or between loads and the structure.

Personnel must keep away from the area below where assembly work is being carried out if the area of risk is not protected from objects that could fall, tip over, slide or roll away. The area of risk is to be cordoned off.

Access means

Safe access to all working areas must be guaranteed at all times.

Preferred options are walkways, stairs, stair towers or site lifts. Ladders are only suitable for use as access means in exceptional cases.

In the case of an emergency situation, the working areas must have escape routes in place or suitable rescue equipment available.

It must also be ensured that at least one emergency escape route or piece of rescue equipment can still be used if the power supply fails.

The access areas on the jobsite must be free of obstacles and tripping hazards, as well as being slip-resistant.

Protection against falling objects

Avoid installing working areas and access points in areas of risk. If this is not possible due to work procedures, suitable protection equipment must be available. This also applies to work requiring only a short period of time.

Tools and materials are to be secured to prevent them from falling to the ground. Concrete excess and other forms of dirt are to be removed at regular intervals. The platforms are to be kept clean at all times. During operating conditions, working areas at great heights are always to be secured against falling objects through the use of suitable construction measures.

Climbing procedure

The climbing enclosure cannot be mounted for the next concreting step until the required concrete strength has been achieved.

As a result of the moving procedure, unprotected falling edges are formed. Such affected areas are to be cordoned off and additional equipment must be in place to secure those persons working at the falling edge e.g. personal protective equipment against falling from a height (PPE)!

Site personnel, construction materials or tools may not be transported with the crane during moving operations. Exceptions to this can be determined through the operational working and assembly instructions on the basis of a corresponding risk assessment.

The climbing procedure must be monitored by a competent and qualified person.

During the climbing procedure, clamping and crushing hazards are present that result from moving components.

Those persons carrying out the climbing procedure must be fully informed about all possible hazards.

All persons who are not required to carry out the climbing procedure must leave the area of risk.

When climbing with the hydraulic climbing device, specifications regarding the arrangement of the hydraulic hoses are to be observed. If the standard arrangement is not possible, an authorised person must determine a safe and secure alternative.

In case of a malfunction, lower the platform to the next possible position, leave the climbing unit in a safe and secure manner and notify an authorised person immediately!

Storage and Transportation

Store and transport components ensuring that no unintentional change in their position is possible. Detach lifting accessories and slings from the lowered components only if they are in a stable position and no unintentional change is possible.

Do not drop the components.

Use PERI lifting accessories and slings and only those load-bearing points provided on the component.

During the moving procedure

- ensure that components are picked up and set down so that unintentional falling over, falling apart, sliding, falling down or rolling is avoided.
- no persons are allowed to remain under the suspended load.

For transportation, the surface used must have sufficient load-bearing capacity.

Use original PERI storage and transport systems, e.g. crate pallets, pallets or stacking devices.

Component Overview and Tool List



Pos. no.	Component name	Item no.
2	Climbing Rail-2 LPS 784	130265
2.1	Spacer-2 LPS 52	130262
3	Steel Waler Universal SRU 72	103868
4	Climbing Rail-2 LPS 398	130268
5	Rail Connector LPS	117245
5.1	Screen Support LPS M20	127875
6	Rail Connector SRU/LPS	124682
7	Crane Eye BR-2 2.5 t	127834
8	Bracing Connector LPS	129814
8.1	Bracing Chain LPS 5.0 m	129570
9	Lifting Beam 10 t	127320
10	Slab Shoe-2 LPS, adjustable	128562
11	Slab Shoe Corner-2 LPS	128883
12	Rail Guidance Shoe-2 LPS	128799
13	Anchoring M24	
13.1	Screw-On Cone-2 M24/DW 20	114158
13.2	Threaded Anchor Plate DW 20	030860
13.3	Anchor Sleeve M24	026230
13.4	Spacer for Anchor Sleeve M24	026240
13.5	Climbing Cone-2 M24/DW 15	031220
13.6	Tie Rod DW 15	030030
13.7	Threaded Anchor Plate DW 15 Ø 80 mm	030840
13.8	Spacer Tube Ø 22, LT = h – 185 mm	065027
13.9	KK Concrete Cone M24	031652
13.10	Plug PP Ø 26 mm	026250
14	PERI Anchor Bolt 14/20x130	124777
15	Bolt ISO 4014-M16x120-8.8	105402
16	Slab Anchor Template-2 LPS	127347
17	Nut M16x50	
18	Bolt ISO 4017-M16x030-8.8	710231
19	Washer ISO 7089-16-200HV	711043
21	Gitter Panel DX LPS 250 x 123	127568
22	Telescopic Screen DX LPS 123 x 248	127556
24	Screen Adapter Single LPS 60	117166
25	Screen Adapter Double LPS 60	117152
26	Screen Adapter Telescope-2 LPS	127600
27	Screen Adapter Combi LPS 60	117165
28	Screen Adapter Corner LPS	117535
29	Edge Screen Adapter Telescope LPS	128842
30	Edge Screen Adapter Corner LPS	128804
31	Screen Adapter Stacking LPS 60	129796
32	Platform Cantilever Beam LPS	130212
33	Platform LPS 250	125981
34	Platform Beam LPS 235	117129
34.1	Platform Beam LPS 173	126197

Pos. no.	Component name	Item no.
34.2	Platform Beam LPS 123	124575
35.5	Platform Cover LPS 37.5 x 107.5	125974
36.4	Platform Cover Corner LPS 105 x 105	126611
37	Toe Board	
40	Hinged Cover	
41	Flap Hinge LPS Ø 48/M10	125461
42	Flap Safety Plate LPS Ø 48	125458
43	Scaffold Tube Ø 48.3 x 3.2 L = 2.5 m	125976
44	Telescopic Scaffold Tube LPS	125972
46	Scaffold Tube Connector Ø 48-M10 LPS	128317
47	Cover Plate for Internal Corner	
50	Telescope Beam Finishing Platform LPS	129480
51	Support Angle TP LPS 25	129546
54	Platform Cover Finishing Platform LPS	129517
53	Platform Cover TP LPS 92	129530
55	Corner Cover TP LPS, left	129547
56	Corner Cover TP LPS, right	129536
57	Bolt Ø 16x36	118123
60	Cover Mat LPS 60 x 75, U120 – 140	125960
61	Cover Strip LPS 0.20 x 10 m	125973
61.1	Cover Mat LPS 41 x 66	129577
61.2	Cover Mat LPS 41 x 66	129577
62	Cover Strip LPS 20 x 108	126076
62.1	Cover Strip LPS 20 x 158	126834
63	Cover Clip Profile LPS 110	127053
64	Draw-in Profile LPS 18/93	127061
65	Draw-in Profile LPS 20/55	127060
66	Self-Drilling Screw ST 5.5 x 45 – TX30	710262
71	Bolt ISO 4014 M24x70-10.9	026430
72	Bolt ISO 4017 M16x40-8.8	113635
72.1	Nut ISO 7040 M16-8	104024
73	Oval-Head Screw ISO 7380 M10x25-10.9	125991
73.1	Nut ISO 7040 M10-8	780356
74	Clamp A64 DIN 3570 M12	110296
74.1	Nut ISO 4032 M12-8	104526
75	Cable Binder PA 6.6 SW 203x7.6	126268
76	Timber	
77	Bolt ISO 7380-M10X040-10.9-VZ	129571
78	Flat Round Screw DIN 603 M8x100 MU	710240
79	Untreated Plywood 20, 21 mm	
81	Fitting Pin Ø 21x120	104031
82	Toe Board Angle 90°	123478
83	SPAX 6x20 TX30	129711
84	SPAX 5x25 SK-TX 25	105847
84.1	TSS Torx 6x60	024470

Pos. no.	Component name	Item no.
85	Hinge DIN 7957-200	111436
86	Cotter Pin 4/1	018060
87	Bolt ISO 4014 M20 x 90-8.8	710226
88	Nut ISO 7042 M20-8	781053
90	Climbing Device LPS 30 kN	125815
91	Hydraulic Pump RCS 4x190 bar	109766
92	Hydraulic Twin Hose RCS 10 m	110069
93	Adapter Cable RCS	110280
94	Plug Socket RCS	110279
96	Reinforcement	
97	Tie Rod	
98	Guide-in Tool RCS	114317
99	Guardrail	

Tool name
Ratchet Wrench
Extension for the Ratchet Wrench
Wrench Socket SW 36
Allen Key SW 6 / SW 8 / SW 10
Spirit Level
Cordless Screwdriver
Screw Bits TORX 25, 30
Ring / Open-end Wrench SW 13 / SW 16 / SW 18 / SW 24 / SW 30 / SW 36
4-sling Lifting Gear
Circular Saw
Torque Wrench
Hammer
Round Slings

Tightening Torque

For the screw connections, PERI recommends the following "hand-tightened" tightening torque MA, hand-tightened according to Eurocode 3 and DIN EN 1090-2:

Screw	M20	M24	M30	M36
MA, hand-tightened	60 Nm	110 Nm	220 Nm	350 Nm

Tightening torque has been determined for the following components:

Clamping Screw for Screen Adapter	80 Nm
Nut for Screen Adapter	80 Nm
Climbing Bolt for Spacer	60 Nm
Turnbuckle, oiled	Hand-tightened
Turnbuckle, dry	Hand-tightened + one complete turn (360°)

Climbing Enclosure

The climbing enclosure can be assembled in 2 basic versions.

Version 1:
Climbing enclosure with straight protection screen. (Fig. A1.01)

Version 2:
Climbing enclosure with working platform. (Fig. A1.02)

In both versions, the Climbing Rails (2) are supported by Slab Shoes (10), which are mounted on pre-completed floor slabs.

The mesh panels (21) are mounted on the Climbing Rails (2) using Screen Adapters. Additional Telescopic Screens (22) can be mounted on both versions.

Spacings between floor slabs and the climbing enclosure are closed with foldable covers (40). During the climbing procedure, these are folded up and secured in position.

In Version 2, one Platform LPS (33) and one Enclosure Post (4) are mounted on the Climbing Rail.

Assembly of the climbing enclosure varies depending on the storey height and projection of the slab formwork.

Version 1

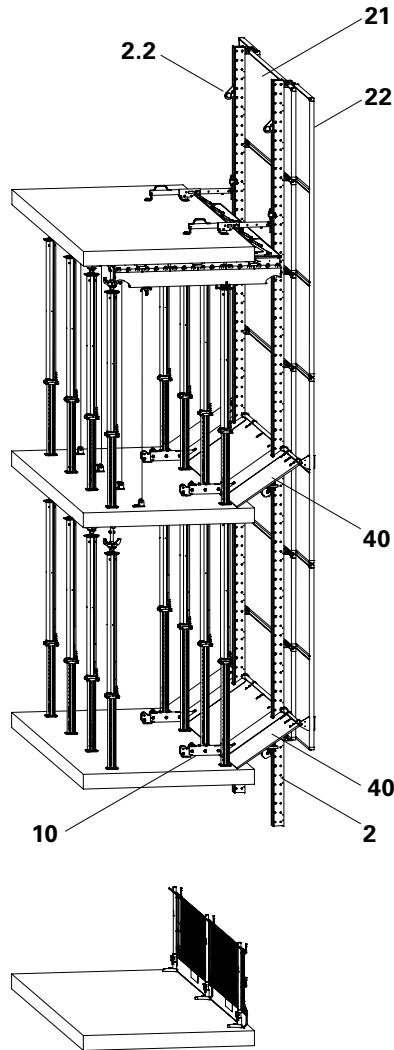

Fig. A1.01

Version 2

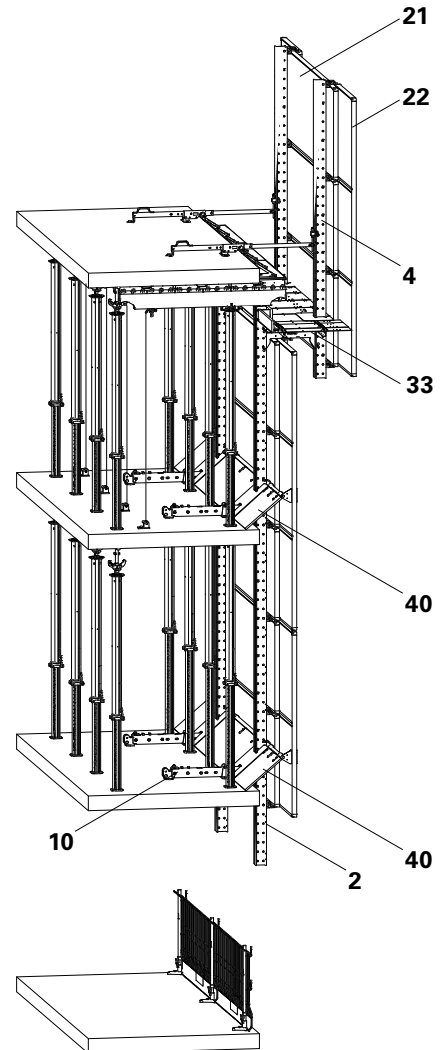

Fig. A1.02

Components

- 2** Climbing Rail-2 LPS 748 or 998
- 2.1** Spacer LPS 52 (Climbing Bolts)
- 2.2** Attachment point
- 4** Climbing Rail-2 LPS 398
- 10** Slab Shoe LPS, adjustable
- 13** Anchoring M24
- 14** PERI Anchor Bolt 14/20x130
- 21** Screen Element LPS
- 22** Telescopic Screen LPS
- 23** Screen Adapter LPS
- 32** Platform Cantilever Beam LPS
- 33** Platform LPS
- 40** Foldable Cover
- 90** Climbing Device LPS 30 kN

Abbreviations used in these Instructions for Assembly and Use:

- $a_{1,2}$ Anchor spacing to slab edge
- B Width of the protection screen
- B_0 Width of Screen Element
- $B_{1,2}$ Projection of the Telescopic Screen
- b Width of influence of a bracket
- b_1 Support distance
- c Distance of the bracket axes in the layout
- c_c Distance between climbing units
- c_1 Adjustment length of Slab Anchor Template
- c_2 Lateral distance to edge of anchoring
- $d_{1,2}$ Dimension outer edge of Screen Element to middle of Climbing Rail
- d_x Distance between building edge and stop on the Slab Shoe hBStorey height = 2.80 - 4.50 m
- F Fibre direction
- G Weight
- $H_{1,2}$ Horizontal force on Slab Shoe
- h_B Storey height = 2.80 - 4.50 m
- h_G Operating height above ground
- h_1 Projecting height of the protection panel
- h_P Height of Climbing Rail above top edge of the concrete
- h_S Height of slab formwork above the working platform
- h_{nom} Installation depth of anchoring
- L_S Length of tie rod
- L_T Length of Spacer Tube
- $L_{1,2}$ Length of Climbing Rail
- N_A Anchor tension force
- Q_A Anchor shear force
- q Wind load
- S Bolt spacing
- S_1 Gap dimension
- V_C Support force of the slab
- $V_{1,2}$ Vertical force
- X Distance to edge of building columns
- α Crane sling angle
- Δ_h Horizontal dimension

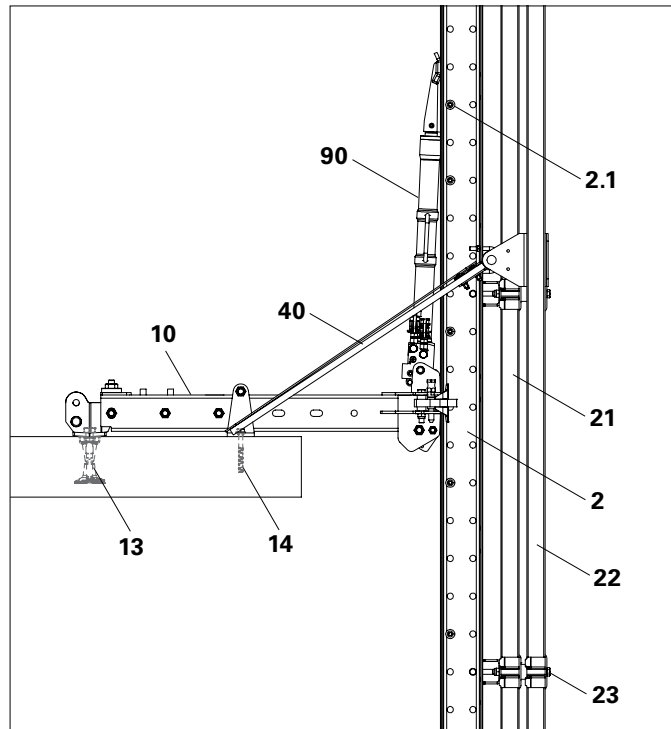

Fig. A1.03

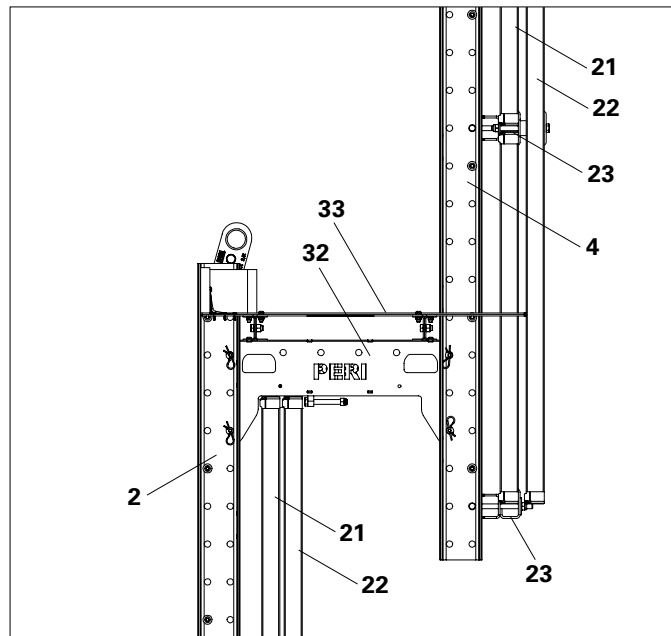

Fig. A1.04

Climbing Device and Hydraulics

This section provides basic information about the climbing device and hydraulic pump. Further information is provided in the following sections, as well as in the separate Instructions for Use for the LPS Climbing Device and Hydraulics.

Climbing Device LPS 30

The Climbing Device LPS 30 facilitates gradual climbing of the climbing enclosure.

After the climbing procedure is completed, the climbing enclosure must be placed on the climbing pawls of the slab shoes ensuring that the load is fully supported. The climbing device must be load-free. (Fig. A2.01 + A2.02)

Main components

- 90** Climbing Device LPS 30 1*
- 90.1** Piston head with claw
- 90.2** Cylinder base
- 90.3** Return from the piston side with hydraulic quick coupler (nipple) to angle screw with protective cover
- 90.4** Inflow to the piston base with hydraulic quick coupler (bushing) to angle screw with protective cover
- 90.5** **Cylinder reposition device (spring-loaded)**
- 90.6** Locking lever (spring-loaded)

The quick couplers on the climbing device and hydraulic pump are interchangeable. Feed line and return line cannot be mixed up.

1* safety components.

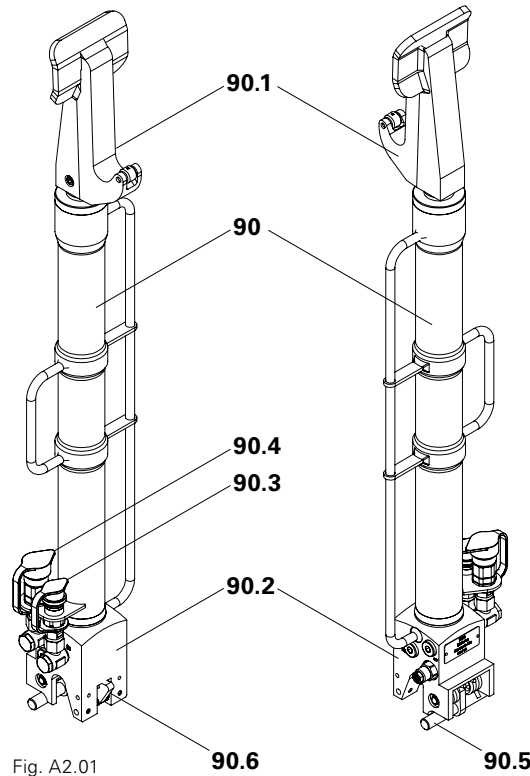

Fig. A2.01

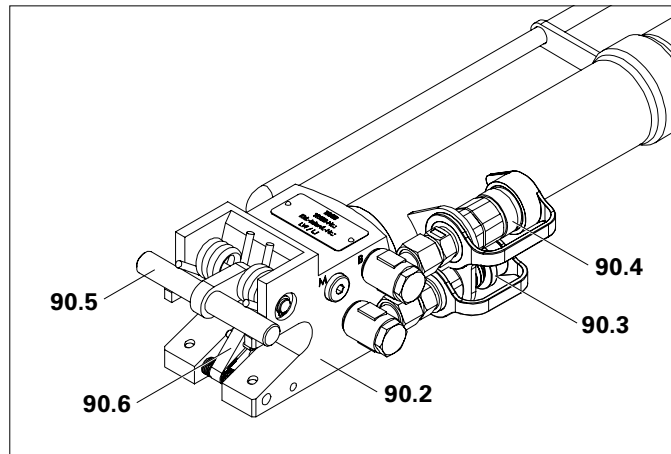

Fig. A2.02

Hydraulic pump

Hydraulic Pump RCS 4 x 190 bar,
380 – 460 V for 4 climbing devices 1*
(Fig. A2.03)

Main components

- 91.1** Operating lever
- 91.2** Switch unit
- 91.3** Electricity socket with phase in-
verter
- 91.4 Hydraulic oil tank**
- 91.5** Filling piece
- 91.6** Oil level indicator; thermometer
- 91.7** Oil filter
- Return from the piston side of
the cylinder with hydraulic
quick coupler (bushing)**
- 91.9** Inflow to the piston head side of
the cylinder with hydraulic quick
coupler (nipple)
- 91.10 Rotary field control lamp**

Accessories:

(Fig. A2.04 + A2.05)

- 93** Adapter Cable RCS for supply line
with CEE socket, operational vol-
tage 380 - 400 V / 16A, 50 Hz
- 94** Plug Socket RCS, black for mount-
ing an adapter cable carried out by
a qualified electrician. Operational
voltage 380 - 460 V, 50 - 60 Hz

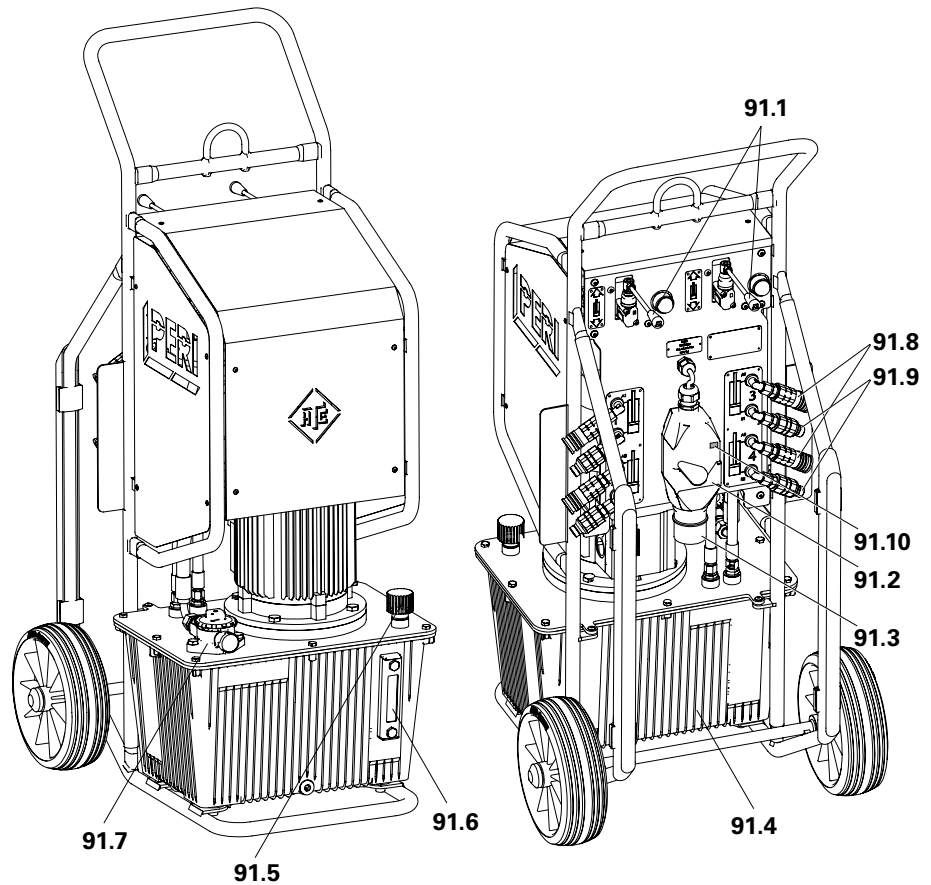

Fig. A2.03

Hydraulic hose

The hydraulic twin hose is available in
lengths of 10 m and 20 m.
(Fig. A2.06)

Main components

- 92** Hydraulic Twin Hose RCS 1*
- 92.3** Hydraulic Quick-Coupler (bushing)
- 92.4** Hydraulic Quick-Coupler (nipple)



During transport, join the two coupling
ends together in order to protect the
hoses.

1* safety components.

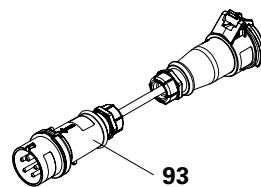

Fig. A2.04

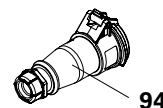

Fig. A2.05

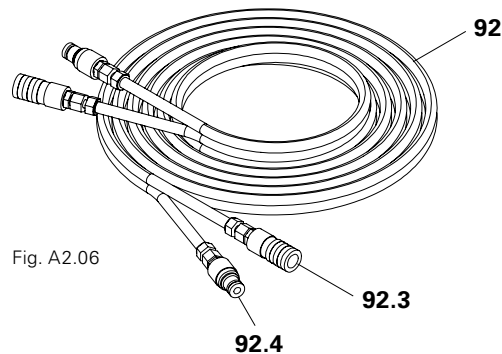

Fig. A2.06

Operating Status and Loads

Operating status: working

All work carried out with protection provided by the climbing protection panel and on its working platforms: assembly of the slab and column formwork, concreting and striking, inspection and maintenance.

- Platforms are freely accessible for the required work to be carried out.
- Max. wind speed km/h.

Operating status: climbing

Moving the climbing unit by crane or by means of the hydraulic climbing device.

- Non-planned loads on the platforms are to be removed.
- Crane-assisted climbing:
Personnel are not allowed on the platforms during the climbing procedure.
- Self-climbing:
Personnel required for climbing are usually on the floor slab.
- Max. wind speed 72 km/h.



The project-related assumed dynamic wind pressure, which was taken as basis for the design, has to be stated on the execution plan.

Live loads

Working platform 150 kg/m²

Finishing platform 75 kg/m² (if available)

Non-operational

During longer work breaks, overnight, in the case of storm warnings, with wind speeds over 100 km/h.

- Accessing the platform during storm conditions is prohibited.
- Materials and equipment are to be removed from the platforms.
- The assumed wind speed (dynamic wind pressure) during storm conditions is calculated based on the respective application height, wind zone and terrain category according to DIN EN 1991-1-4 or (EC 1).
- If given limits are exceeded, a visual inspection of all bearing components and a functional check of all safety components are necessary for further use.
- If a storm warning has higher wind speeds than originally stated, the site management has to be informed. All enclosure tarpaulins are to be removed and the climbing protection panel is to be supported by means of additional struts.
- On the instructions of authorised site personnel, the climbing protection panel can be climbed down to the previous storey. For this, additional instructions are required.

Operating Sequence

The difference in the operating sequence of Versions 1 and 2 is primarily due to when the slab is struck.

Both versions can be climbed with the hydraulic self-climbing device (Fig. A4.04) or by crane (Fig. A4.08).

Version 1

Climbing enclosure with straight protection screen.

The slab formwork can remain in position. The climbing enclosure can climb past the slab formwork.

Example

Operating sequence with shortened cycle times if two sets of SKYDECK Slab Formwork are used.

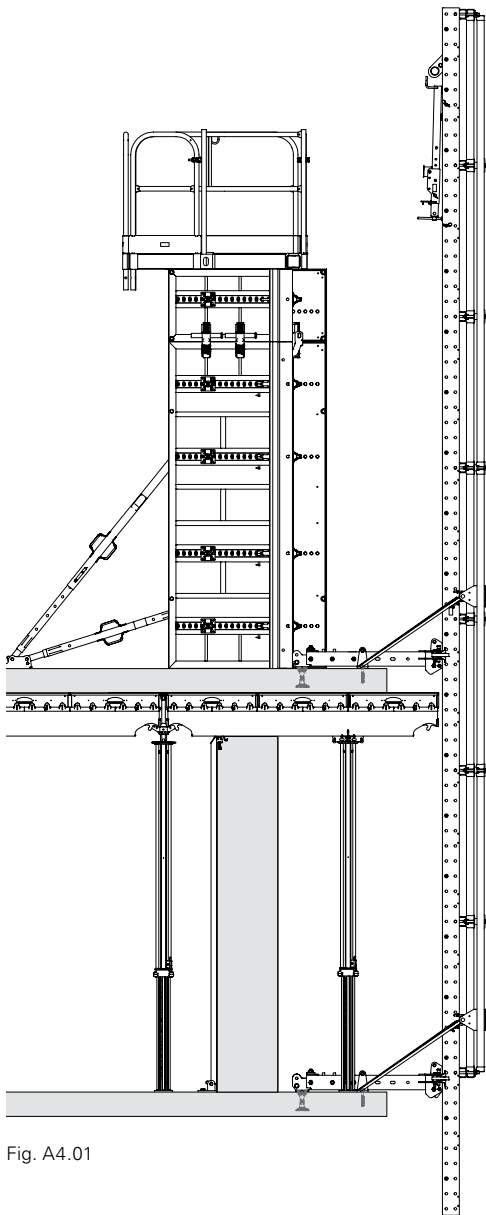

Fig. A4.01

Step 1
Climbing enclosure is in position.
Close cover flaps.
Concrete the columns.

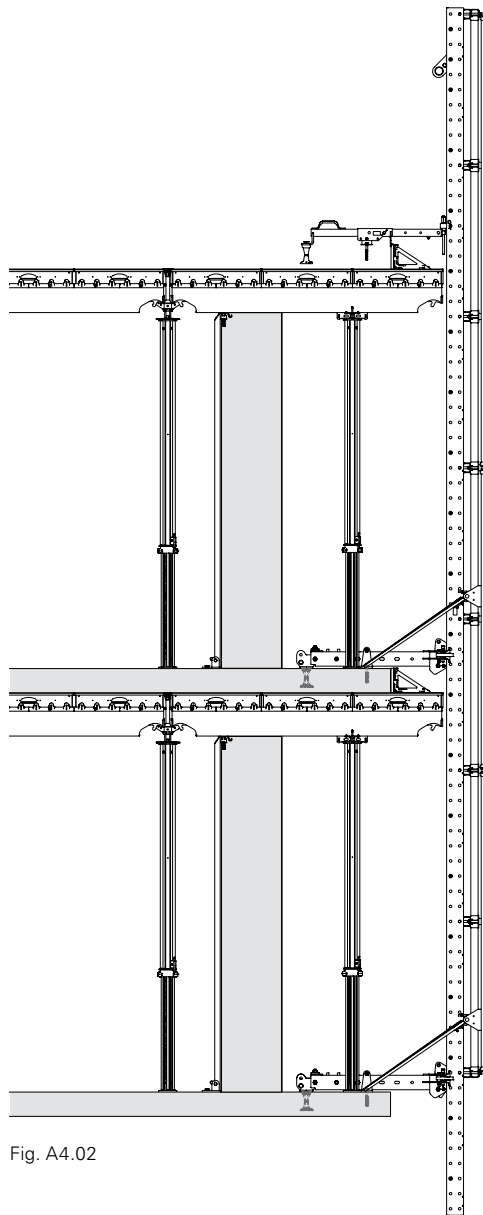

Fig. A4.02

Step 2
Erect slab formwork with stopends.
Install leading anchor with the aid of the Slab Anchor Template.

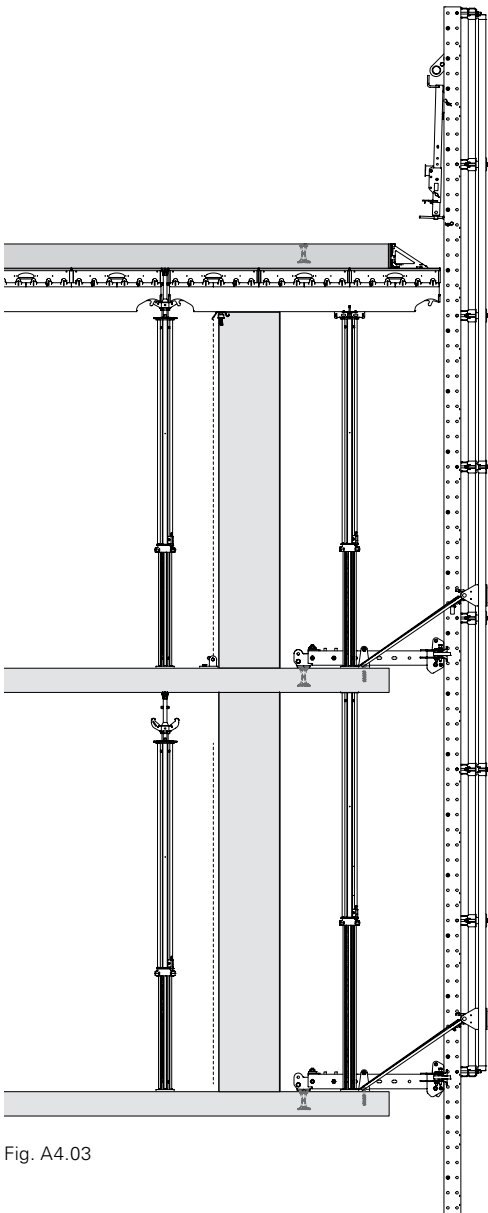

Fig. A4.03

Step 3
 Concrete the slab.
 Fold up the Slab Anchor Template.
 Rework slab.
 Remove bottom slab formwork and back-prop.
 Assemble subsequent guardrails.

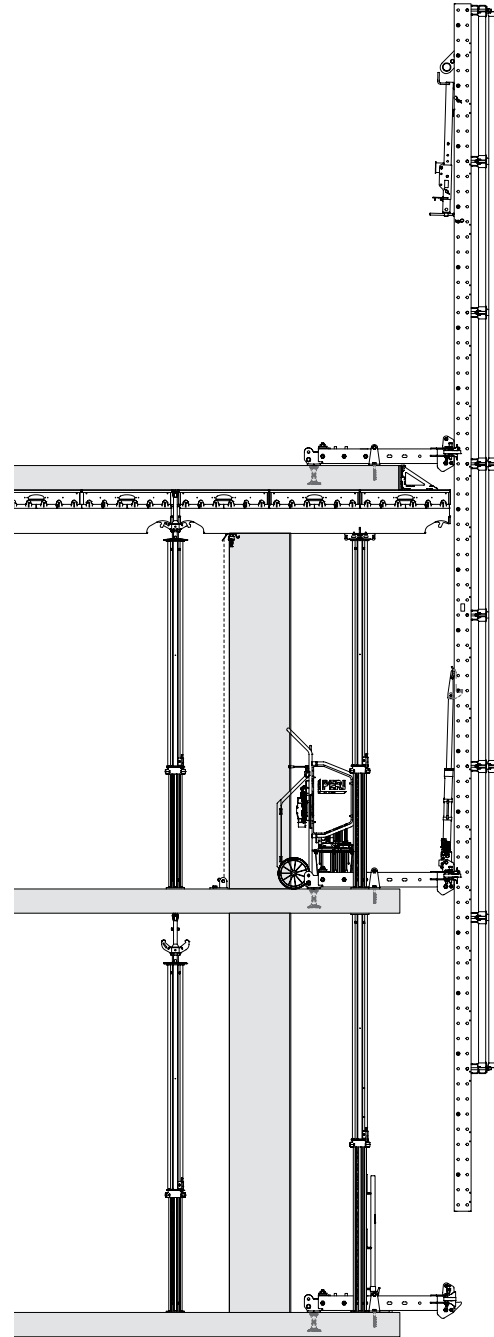

Fig. A4.04

Step 4
 Mount top slab shoe.
 Open cover flaps.
 Climb climbing enclosure hydraulically (as depicted above) or by crane.
 Dismantle bottom slab shoe.

Version 2

Climbing enclosure with working platform.

The slab formwork is in the way for the climbing procedure. PERI recommends a slab formwork system, e.g. SKYDECK, which allows early striking.

Example

Operating sequence with SKYDECK Slab Formwork.

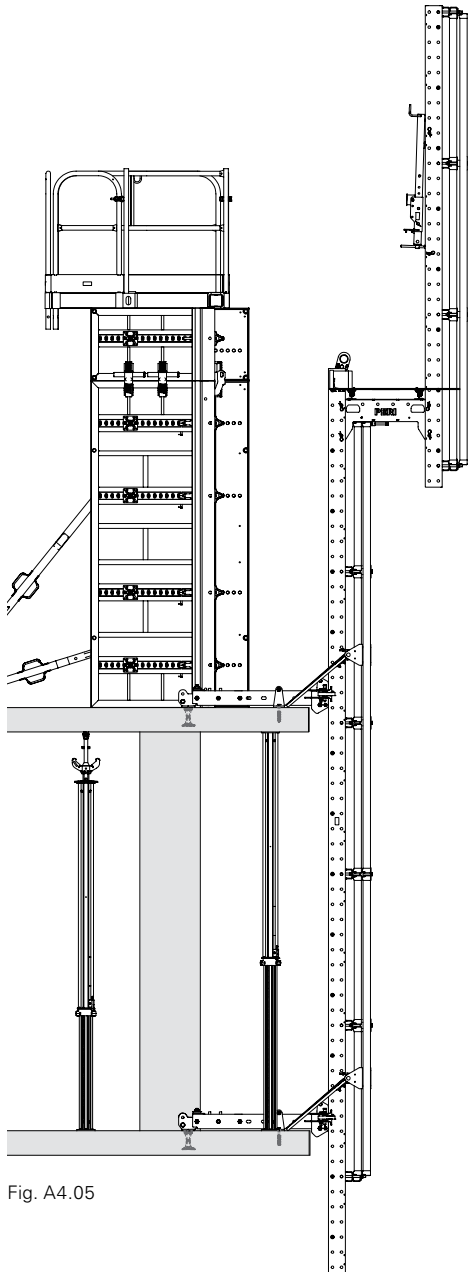

Fig. A4.05

Step 1

Climbing enclosure is in position.
Close cover flaps.
Concrete the columns.

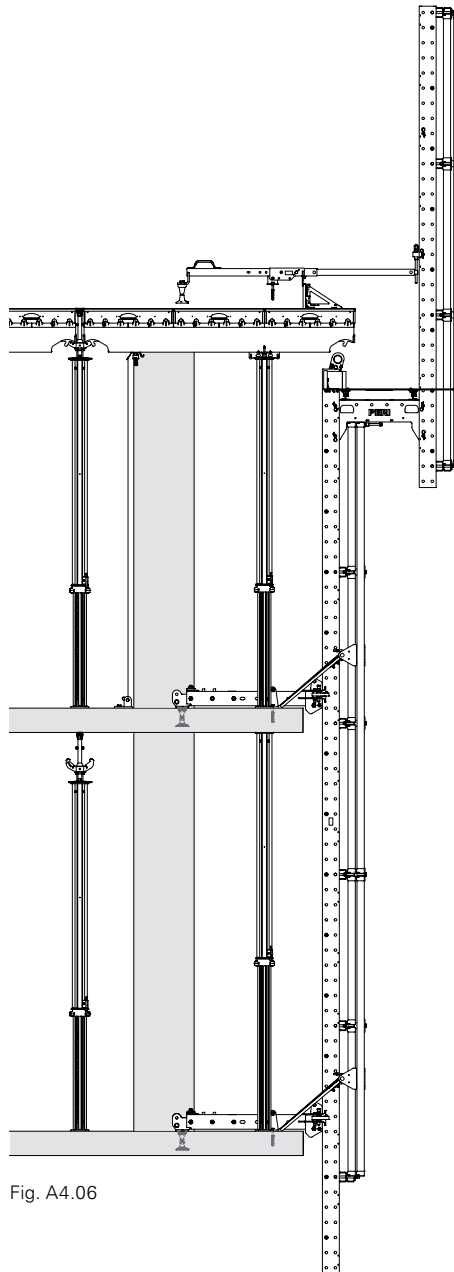

Fig. A4.06

Step 2

Erect slab formwork with stopends.
Install leading anchor with the aid of the Slab Anchor Template.

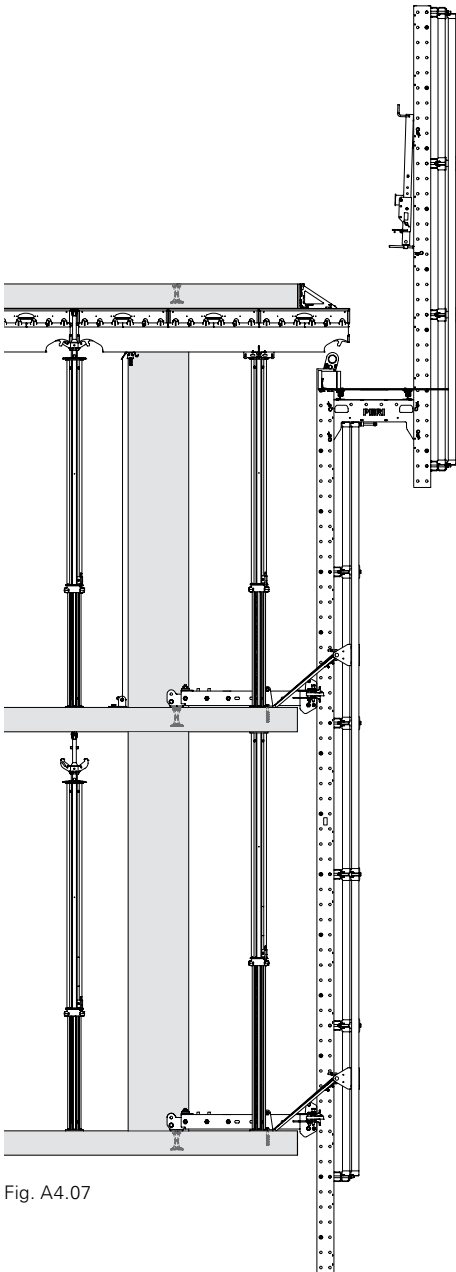

Fig. A4.07

Step 3
 Concrete the slab.
 Fold up the Slab Anchor Template.
 Rework slab.
 Assemble subsequent guardrails.

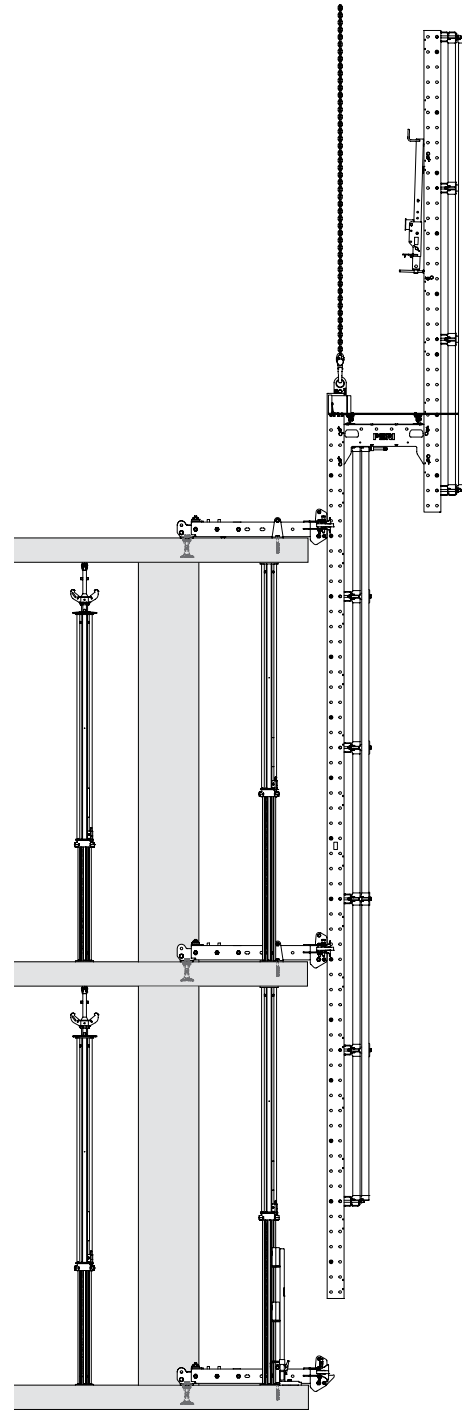

Fig. A4.08

Step 4
 Mount top slab shoe.
 Strip slab formwork and back-prop.
 Open cover flaps.
 Climb climbing enclosure hydraulically (as depicted above) or by crane.
 Dismantle bottom slab shoe.

System Dimensions

Climbing rails

The length of the climbing rail L_1 (2) corresponds to the height of the storeys h_B . It must correspond to at least the height of two successive storeys plus an overlap for safety reasons.

With changing storey heights, the largest dimension of two consecutive storeys must be selected.



- At least 2 slab shoes must guide each climbing rail at all times.
- An extension of the climbing rail with the Steel Waler Universal SRU cannot be used for mounting or guiding in the slab shoes. The top slab shoe must grip the climbing rail underneath the rail joint.
- It is possible to plan so that the climbing rail does not overlap 2 entire storeys for those intermediate storeys with larger storey heights. In this case, self-climbing is not possible. When climbing with the crane, special measures are required because there is no climbing rail guide. These special measures must be defined in manufacturer-specific assembly instructions.

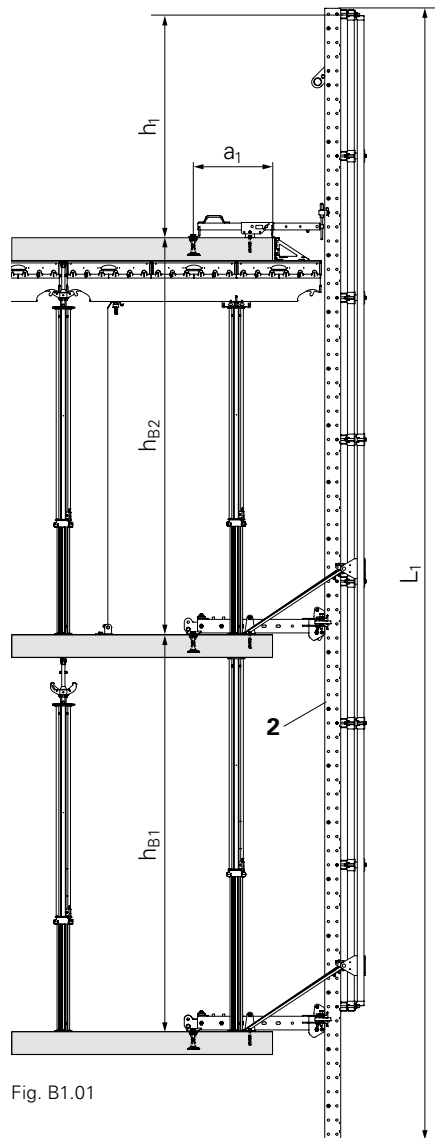

Fig. B1.01

Calculation Version 1.1

Continuous Climbing Rail-2 LPS (2)
(Fig. B1.01)

$$L_1 \geq h_{B1} + h_{B2} + h_1 + 20 \text{ cm.}$$

Calculation Version 1.2

Climbing Rail-2 LPS (2) with top-mounted extension using Steel Waler Universal SRU (3)

(Fig. B1.02)

$$L_1 \geq h_{B1} + h_{B2} + h_p + 20 \text{ cm.}$$

$h_p = 30 \text{ cm}$ without Slab Anchor Template.

$h_p = 60 \text{ cm}$ with Slab Anchor Template.

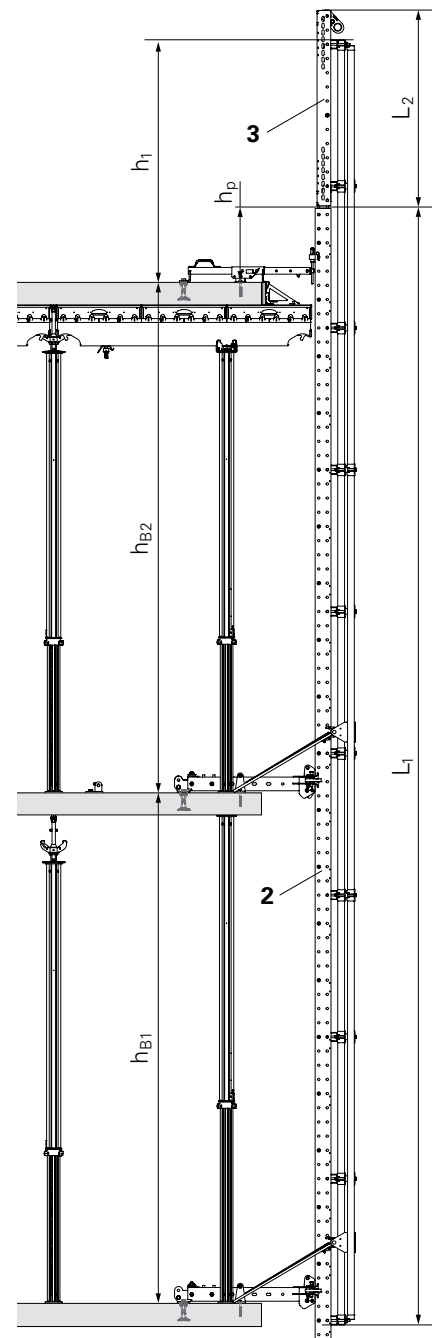

Fig. B1.02

Version 2

Climbing Rail-2 LPS (2) with mounted working platform (32) and Climbing Rail LPS as enclosure post (4). (Fig. B1.03)

Calculation Version 2

Continuous Climbing Rail-2 LPS (2)
(Fig. B1.01)

$$L_1 \geq h_{B1} + h_{B2} + 20 \text{ cm.}$$

Climbing Rail-2 LPS 748 $L_1 = 7.48 \text{ m.}$

Climbing Rail-2 LPS 998 $L_1 = 9.98 \text{ m.}$

Components

-
- 2** Climbing Rail-2 LPS 748 or 998
 - 3** Steel Waler Universal SRU
 - 4** Climbing Rail-2 LPS 398
 - 33** Platform LPS
-

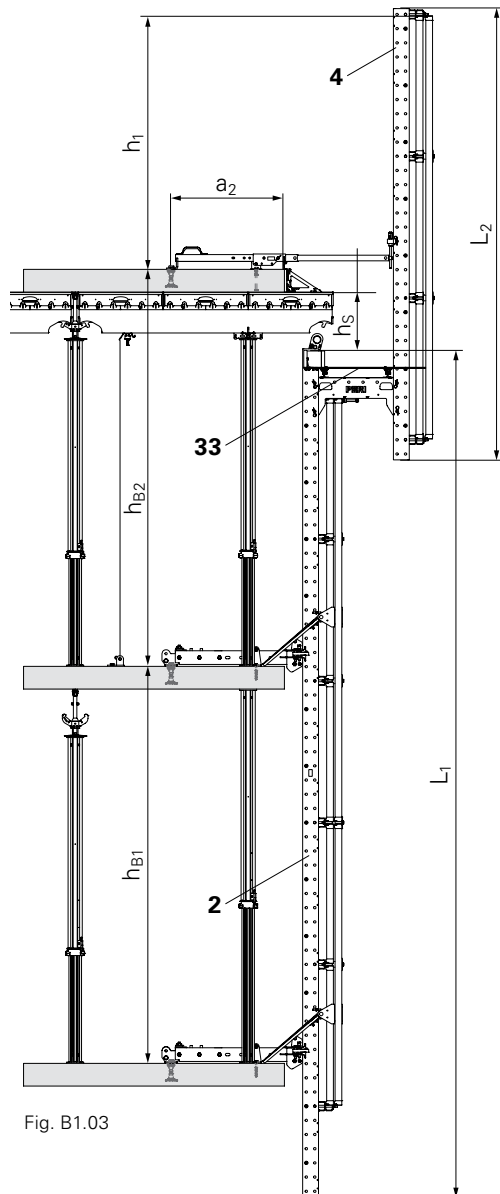

Fig. B1.03

Dependence on Storey Heights

Version 1

Climbing enclosure with straight, continuous screen elements.

For mounting Screen Elements DX LPS (21), the Climbing Rails-2 LPS (2) can be extended upwards to realise larger protection heights.

The extension is carried out using Steel Waler Universal SRU (3) and Rail Connector SRU/LPS (6).

The number and position of the screen elements depend on the respective floor height, as well as the required upper projection.

Screen elements with a height of 1.23 m are mounted on the climbing rails in a system dimension of 1.25 m. The required space of 2 cm for the grid adapters has been taken into account in the system dimension.

The protection area is reduced for all combinations by 2 cm through the top and bottom grid adapters.

For Version 1, Climbing Rail LPS 998 is provided as standard. As a result, a protection height of 8.73 m is possible.

For other possible combinations, see Table B1.01 and illustrations.

Larger protection heights are achieved by means of the extension with Steel Waler SRU. Extension dimensions are limited by the load-bearing capacity of the Rail Connector SRU/LPS.



Other Version 1 combinations are not covered by the standard configuration and require static verification.

Components

- 2** Climbing Rail-2 LPS 748 or 998
- 3** Steel Waler Universal SRU
- 6** Rail Connector SRU/LPS
- 21** Screen Element DX LPS

$h_B = 2,50 \text{ m}$

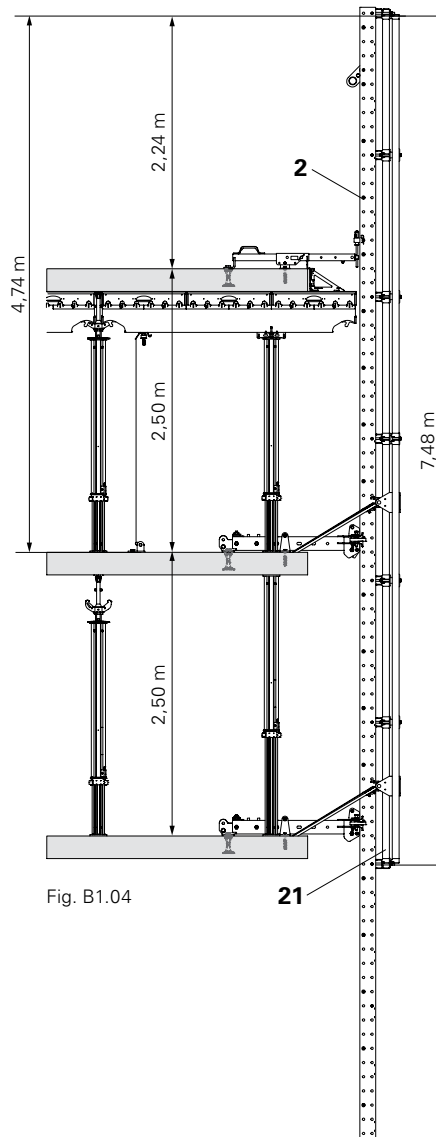

Fig. B1.04

$h_B = 3,00 \text{ m}$

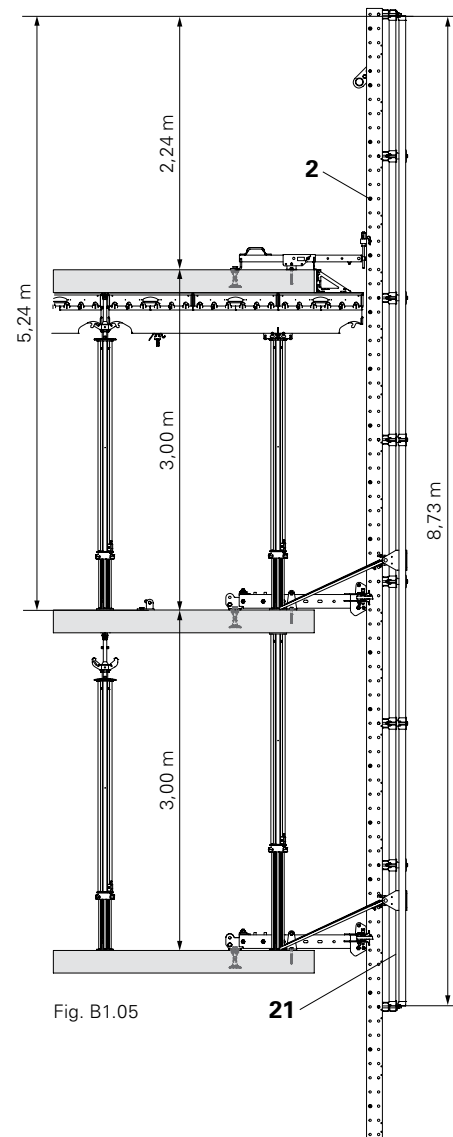

Fig. B1.05

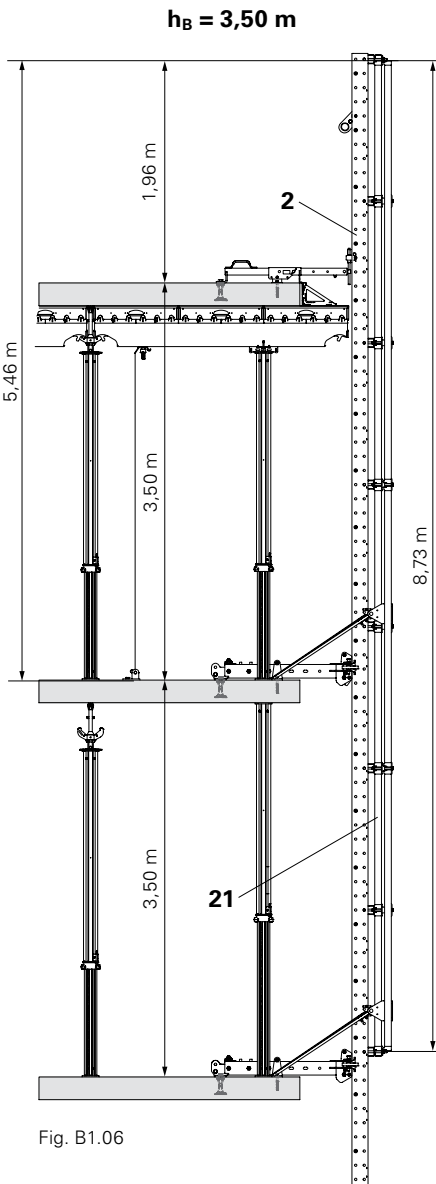

Fig. B1.06

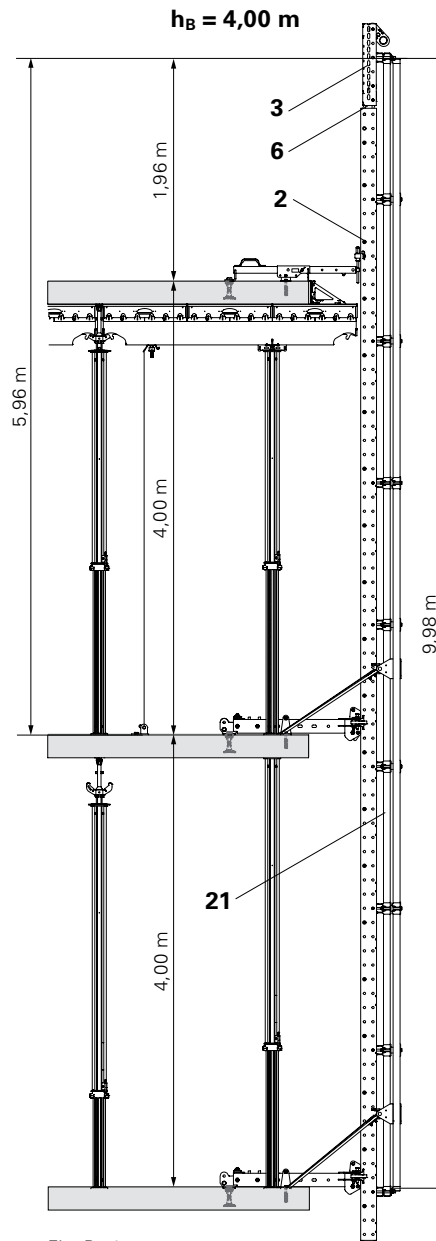

Fig. B1.07

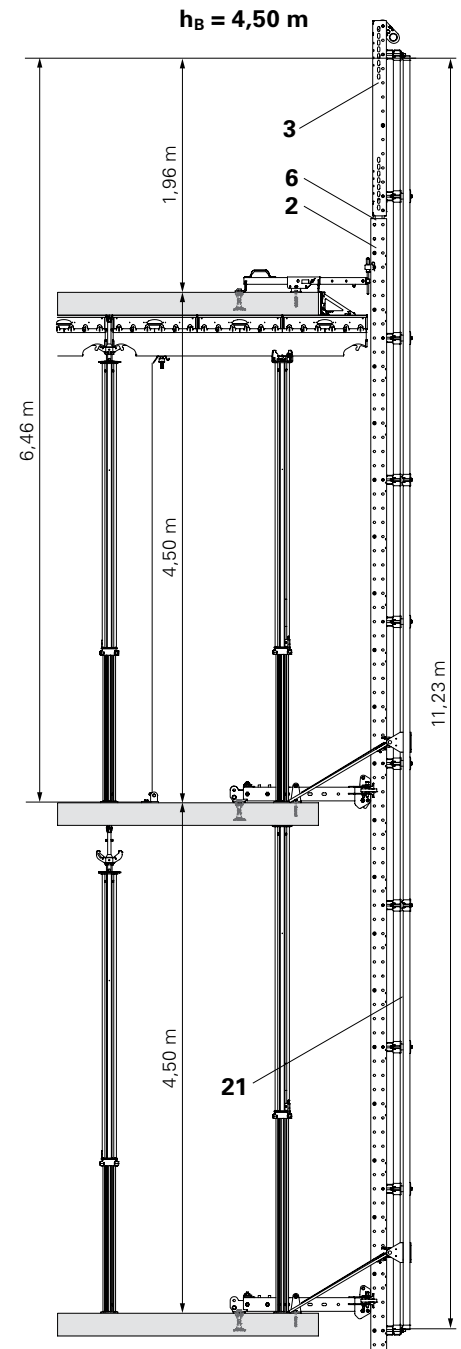

Fig. B1.08

Version 1 – climbing rails dependent on storey heights h_B					
h_B	max $h_{B1} + h_{B2}^*$	Climbing Rail	Screen Element	Protection height in total	Projection h_1
2.50 m	5.00 m	LPS 998	6 rows	7.48 m	2.24 m
3.00 m	6.00 m	LPS 998	7 rows	8.73 m	2.24 m
3.50 m	7.00 m	LPS 998	7 rows	8.73 m	1.96 m
4.00 m	8.00 m	LPS 998 + SRU 72	8 rows	9.98 m	1.96 m
4.50 m	9.00 m	LPS 998 + SRU 172	9 rows	11.23 m	1.96 m

Table B1.01

* 2 x storey height / largest dimension of two consecutive storeys.

Version 2

For screens with working platform, the climbing rail limits the possible storey height.

The distance h_s to the bottom edge of the slab reduces the projecting length h_1 and has to be selected depending on the slab formwork system.

PERI recommends for

SKYDECK	$h_s \geq 0.50$ m
GRIDFLEX	$h_s \geq 0.50$ m
MULTIFLEX	$h_s \geq 0.60$ m

For Version 2, the following is considered as standard:

Climbing Rail LPS 748 or 998 (2) in connection with platform (33) and Climbing Rail LPS 398 (4) as enclosure post.

As a result, a protection height of 7.11 m to 12.11 m is possible.



Other Version 2 combinations are not covered by the standard configuration and require static verification, as well as site-specific assembly instructions.

Components

- 2** Climbing Rail-2 LPS 748 or 998
- 4** Climbing Rail-2 LPS 398
- 21** Screen Element DX LPS
- 33** Platform LPS

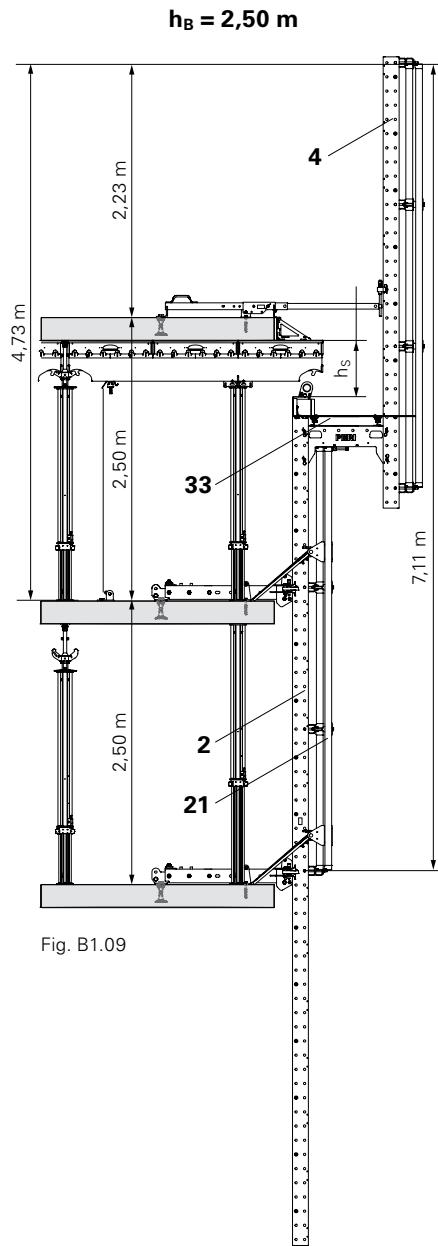

Fig. B1.09

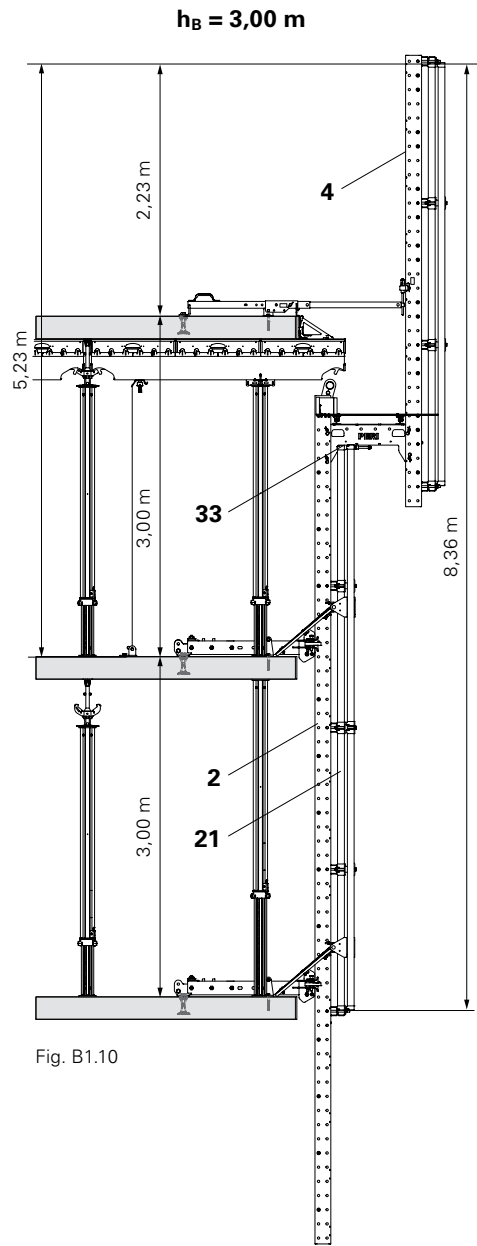

Fig. B1.10

Version 2 – climbing rails dependent on storey height h_B

h_B	max $h_{B1} + h_{B2}^*$	Climbing Rail	Screen Element	Protection height in total	Projection h_1
2.50 m	5.00 m	LPS 748 + 398	3 + 3 rows	7.11 m	2.23 m
3.00 m	6.00 m	LPS 748 + 398	4 + 3 rows	8.36 m	2.23 m
3.50 m	7.00 m	LPS 748 + 398	5 + 3 rows	9.61 m	2.23 m
4.00 m	8.00 m	LPS 998 + 398	6 + 3 rows	10.86 m	2.23 m
4.50 m	9.00 m	LPS 998 + 398	7 + 3 rows	12.11 m	2.23 m

Table B1.02

* 2 x storey height / largest dimension of two consecutive storeys.

** for $h_s = 50$ cm

B1 Planning the Supporting Structure

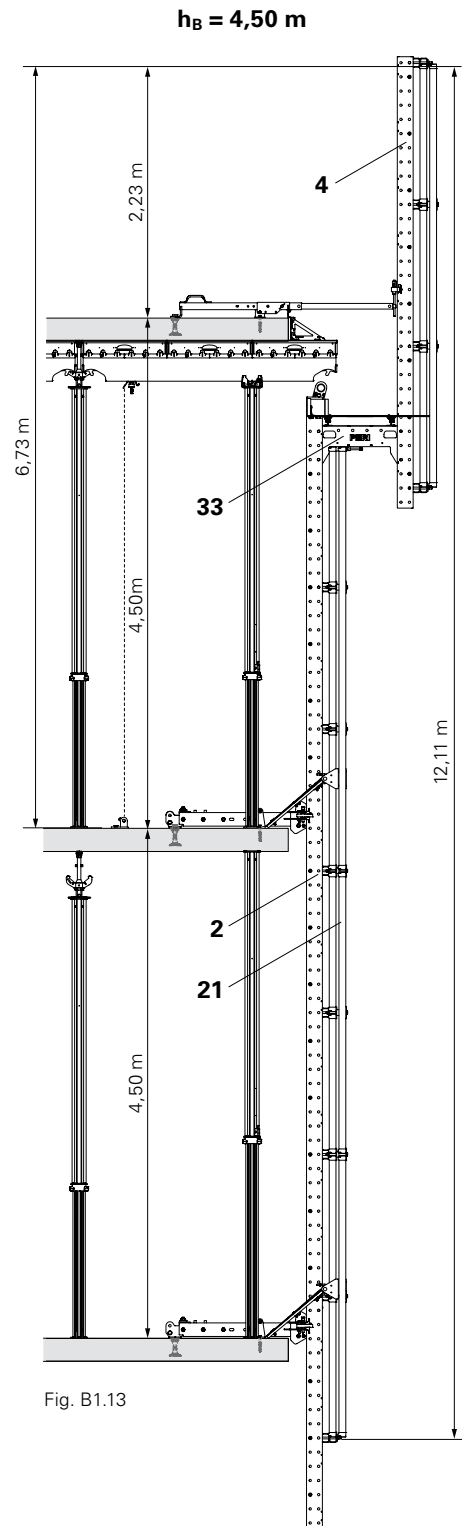
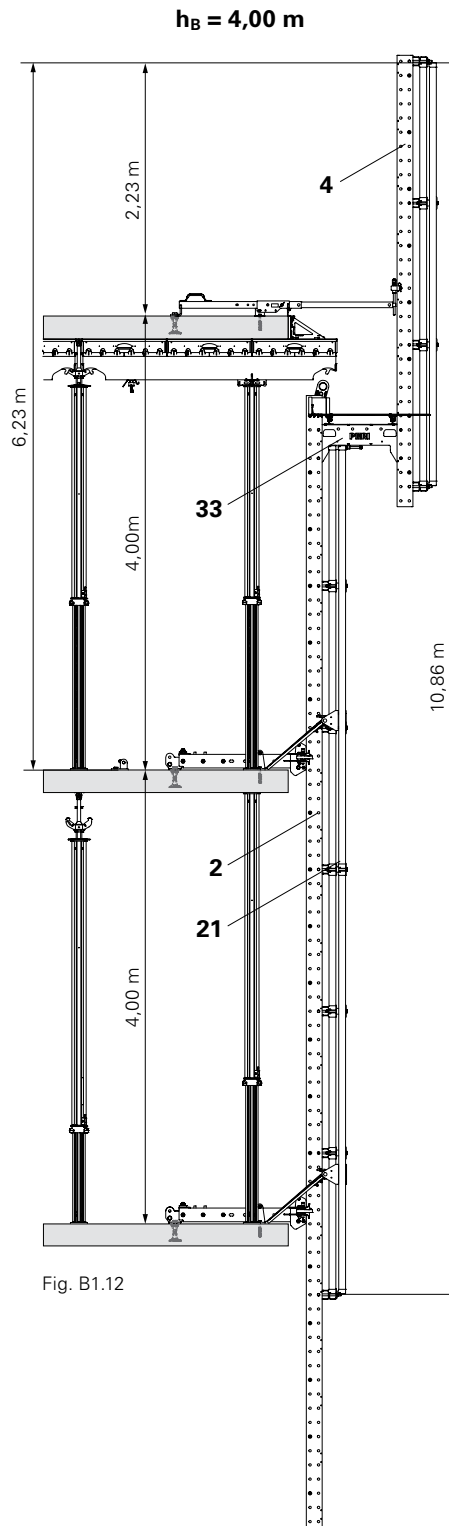
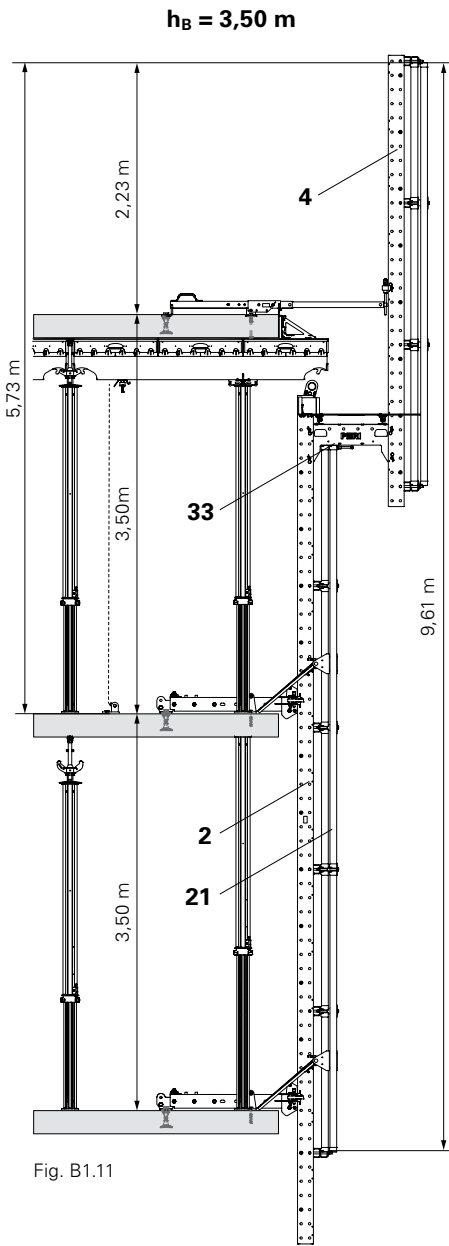

Climbing Rail Spacings

The distance between the climbing rails depends on the mounted screen elements.

Climbing rail distance c especially when using working platforms is:
Width of the screen elements to be mounted B_0 minus 62.5 cm.

Calculation example with Screen Element DX LPS 250:
 $c = 250 \text{ cm} - 62.5 \text{ cm} = 187.5 \text{ cm}$.

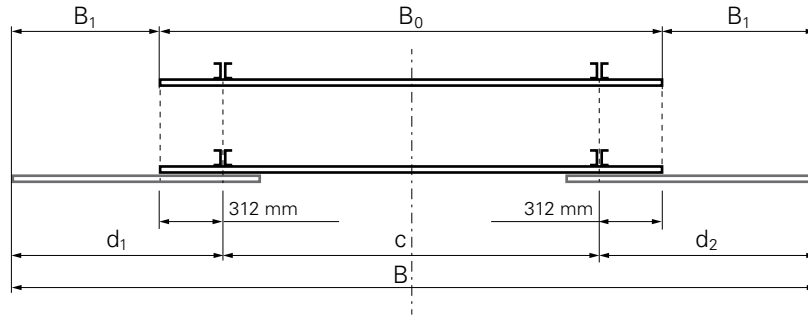

Fig. B1.14



PERI recommends arranging the screen elements symmetrically on the climbing rails.

Dimension outer edge of screen element to middle of climbing rail
 $d = 625 \text{ mm} / 2 = 312.5 \text{ mm}$.

Telescopic screens have no influence on the climbing rail spacing.
(Fig. B1.14)



Accurately maintain the distance of the climbing rails. Otherwise, mounting parts, e.g. platforms, cannot be installed.

Other climbing rail spacings require:

- exact planning,
- static calculations,
- platform modification if necessary,
- site-specific assembly instructions.



For Version 1 with straight protection screen, the position of the climbing rails on the screen elements can be varied accordingly.

With the use of Combi Adapters:
Screen Adapter without Telescopic Screen:
 $c \leq B_0 - 160 \text{ mm}$
Screen Adapter with Screen Adapter Telescope: $c \leq B_0 - 440 \text{ mm}$

The use of platforms and trailing platforms is then not possible. The arrangement and size of the flaps and bracing are to be adjusted accordingly. The width of influence is to be determined separately.

Width of influence for symmetrically extended telescopic screens						
Screen element width B_0	Spacing of climbing rails c	Extension width of the Telescopic Screen $B_1 = B_2$				
		0.00 m	0.50 m	0.75 m	0.87 m	1.05 m*
Width of influence $B_1 = B_2$						
2.50 m	1.875 m	1.25 m	1.75 m	2.00 m	2.12 m	2.30 m
3.00 m	2.375 m	1.50 m	2.00 m	2.25 m	2.37 m	2.55 m
3.50 m	2.875 m	1.75 m	2.25 m	2.50 m	2.62 m	2.80 m
5.00 m	4.375 m	2.50 m	3.00 m	3.25 m	3.37 m	3.55 m

Table B1.03

* Only when using the Screen Adapter Telescope-2.

Additional Spacers

On the climbing rails, spacers are mounted at a distance of 50 cm. Additional spacers (2.1) can be installed on the climbing rail (2). This allows the height of the climbing enclosure to be adjusted in increments of 125 mm.

(Fig. B1.15)

Spacers are used for supporting the climbing enclosure on slab shoes during working operations.

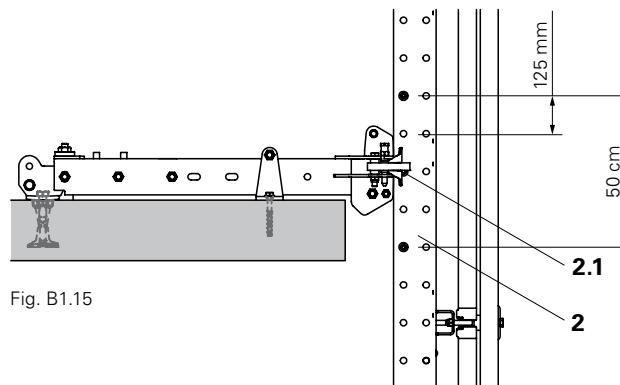

Fig. B1.15



PERI recommends mounting an additional Spacer LPS 52 for standard storey heights that are multiples of 50 cm. This ensures a definite bearing on the planned slab shoe without having to deactivate the other slab shoes.

Suspension with the Slab Shoe

Suspension overview

- 2** Climbing Rail-2 LPS
- 2.1** Spacer LPS 52
- 10** Slab Shoe-2 LPS, adjustable 1*
- 10.2** Climbing Pawl
- 10.3** Folding Runners
- 10.6** Guide Bracket-2 LPS
- 13** Anchoring M24
- 14** PERI Anchor Bolt 14/20x130 1*
- 16** Slab Anchor Template-2 LPS
- 16.4** Height Adjustment
- 16.7** Support M24
- 71** Bolt ISO 4014 M24x70-10.9 1*

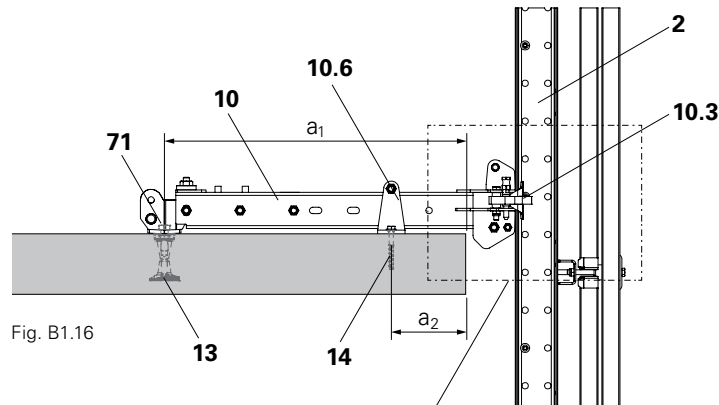

Fig. B1.16

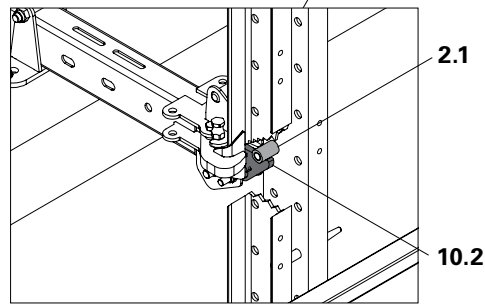

Fig. B1.16a

Anchor fixations

Anchoring M24 is possible in 4 versions:
 Version 1 Screw-On Cone M24/DW 20
 Version 2 Anchor Sleeve M24
 Version 3 Climbing Cone-2 M24/DW 15
 Version 4 Climbing Cone-2 M24/DW 15, completely re-usable

Standard anchor spacings:

Version 1: $a_1 = 700 \text{ mm}$, $a_2 = 200 \text{ mm}$.
 Version 2: $a_1 = 1000 \text{ mm}$, $a_2 = 250 \text{ mm}$.
 Adjustment range 1 610 – 1000 mm.

Leading anchors (13) are fixed in their position during concreting by means of the Anchor Support M24 (16.7) of the Slab Anchor Template LPS (16). The Slab Anchor Template rests on the stopend formwork and is configured by means of height adjustment (16.4).



The stop on the support plate creates an impression in the concrete.

1* All suspension and anchoring parts are safety components.

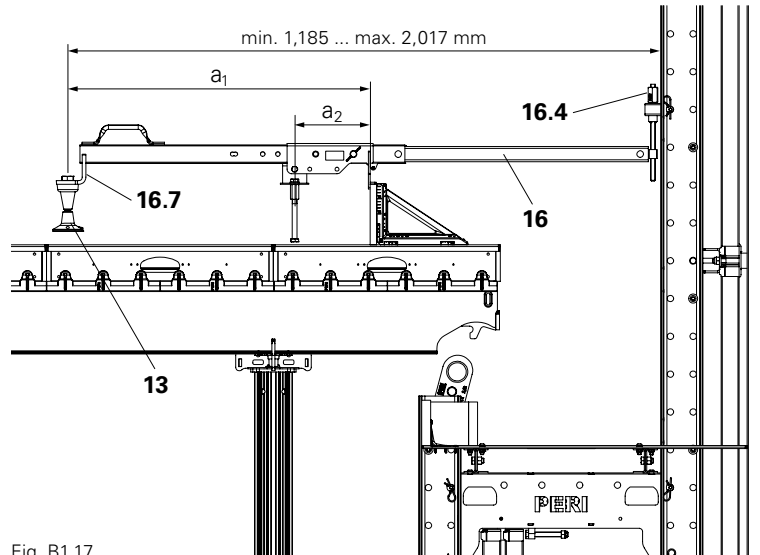

Fig. B1.17

Anchoring

Version 1:

with Screw-On Cone M24/DW 20.
(Fig. B1.18)

Components

- 13.1** Screw-On Cone-2 M24/DW 20 1*
- 13.2** Threaded Anchor Plate DW 20 1*
2* Ø 100 mm

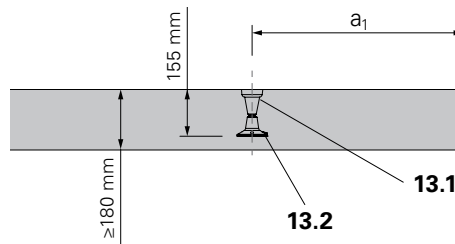

Fig. B1.18



Approval No. Z-21.6-1766
or expert's report for PERI Climbing
Anchor.

Version 2:

with Anchor Sleeve M24.
(Fig. B1.19)

Components

- 13.3** Anchor Sleeve M24 1* 2*
- 13.4** Spacer for Anchor Sleeve M24 1* 2*

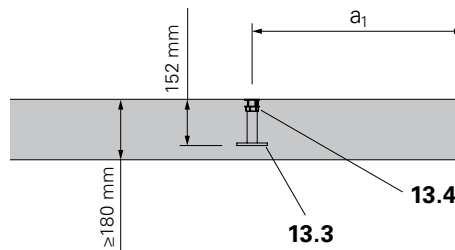

Fig. B1.19



Approval No. Z-21.6-1768
or expert's report for PERI Anchor
Sleeve M24.

Version 3:

with Climbing Cone-2 M24/DW 15.
(Fig. B1.20)

Components

- 13.5** Climbing Cone-2 M24/DW 15 1*
- 13.6** Tie Rod DW 15 1* 2* or
Tie Rod B 15 1* 2*
- LS = hnom - 80 mm
- 13.7** Threaded Anchor Plate DW 15 1*
2* Ø 80 mm

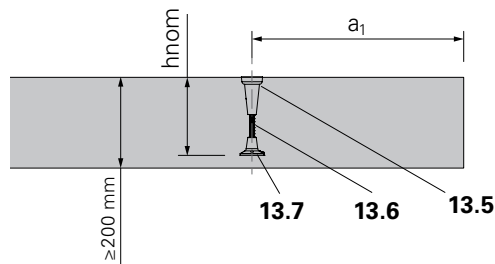
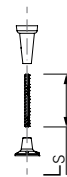

Fig. B1.20



Approval No. Z-21.6-1767
or expert's report for PERI Climbing
Anchor

- 1* All suspension and anchoring parts
are safety components.
- 2* Non-reusable component.

Version 4:

with Climbing Cone-2 M24/DW 15, completely re-usable.
(Fig. B1.21)

Components

- 13.5** Climbing Cone-2 M24/DW 15 ^{1*}
 $h_{nom} = h \geq 185 \text{ mm}$
- 13.6** Tie Rod DW 15 ^{1*}
or Tie Rod B 15 ^{1*}
 $L_S = h_{nom} - 80 \text{ mm}$
- 13.7** Threaded Anchor Plate DW 15 ^{1*}
 $\varnothing 80 \text{ mm}$, nailed for positioning
on the slab formwork
- 13.8** Spacer Tube $\varnothing 22$,
 $L_T = h - 185 \text{ mm}$ ^{2*}

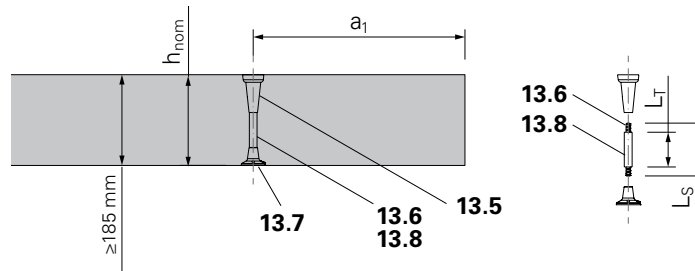

Fig. B1.21

Approval No. Z-21.6-1767
or expert's report for PERI Climbing
Anchor.



Fixing the Threaded Anchor Plate to the slab formwork is not allowed especially with architectural concrete.

- ^{1*} All suspension and anchoring parts are safety components.
- ^{2*} Non-reusable component.

Anchoring of the front support

Subsequent anchoring

Fix Slab Shoe-2 LPS in the drilled holes $\varnothing 14$ using PERI Anchor Bolts 14/20x130, item no. 124777. Take into consideration the Technical Data Sheet! (See Fig. B1.16)



Anchors can also be prepared as an alternative to subsequent anchoring at the front with Anchor Bolts 14/20x130.

Prepared anchoring

Use 2 Bolts M16x120 (15) with 2 long Nuts M16x50 (17) as anchoring. For preparation, screw in the bolts approx. 20 mm into the nuts. Fix the prepared anchors with short Bolts M16x30 (18) and Washers A16 (19) in the bracket for the Anchor Bolt (16.6). Prepared anchors remain in the concrete after dismantling the slab shoe. (Fig. B1.22)

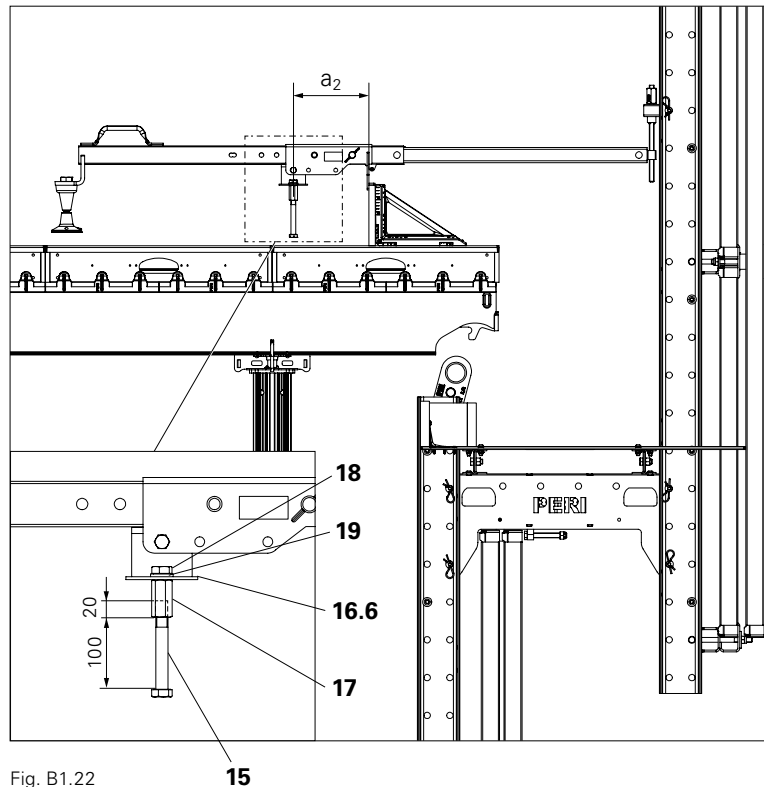

Fig. B1.22

Components

- 15** Bolt ISO 4014-M16x120-8.8 ^{2*}
- 16.6** Bracket for Anchor Bolt
- 17** Nut M16x50 ^{2*}
- 18** Bolt M16x30 ^{1*}
- 19** Washer A16

^{2*} Non-reusable component.

Mixed Suspension with Rail Guidance Shoe and Slab Shoe

Fix Rail Guidance Shoe-2 LPS (12) in the anchoring (13) using Hex. Bolt ISO 4014 M24x70-10.9 (71).
(Fig. B1.23 + B1.24)

Components

- | | |
|-------------|--------------------------------------|
| 12 | Rail Guidance Shoe-2 LPS |
| 13 | Anchoring M24 |
| 13.5 | Climbing Cone-2 M24/DW 15 |
| 13.6 | Tie Rod DW 15, L = h - 77 mm |
| 13.7 | Threaded Anchor Plate DW 15, Ø 80 mm |
| 71 | Bolt ISO 4014 M24x70-10.9 1* |

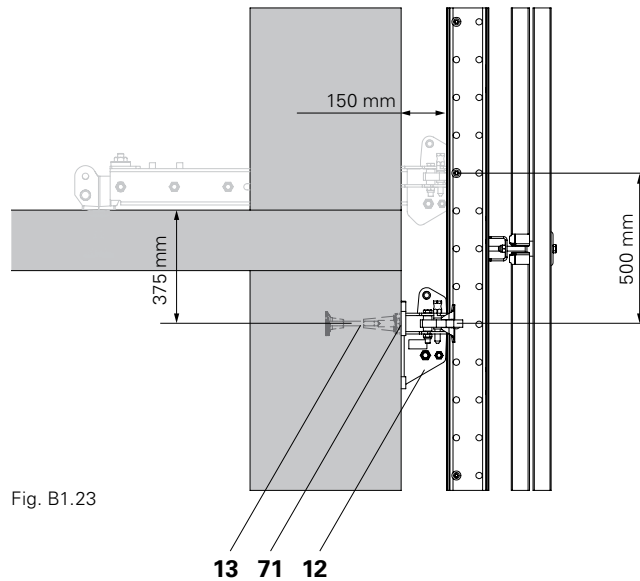

Fig. B1.23

Dimension $\Delta h = 375$ mm, see Section B4 Special Applications - Anchoring to Columns.



- Required anchoring depth h_{nom} and concrete strength according to separate static calculation in accordance with Building Authority Approval Z-21.6-1767 or expert's report for PERI Climbing Anchor.
- Separate static proof and a separate determination of the reaction forces are required!
- When using additional spacers in the standard area, these must be installed offset by 500 mm for the bearing with the Rail Guidance Shoe.

When dismantling the Rail Guidance Shoe, safety measures are required which must be stated in the site-specific assembly instructions, e.g. mounting an additional trailing platform.

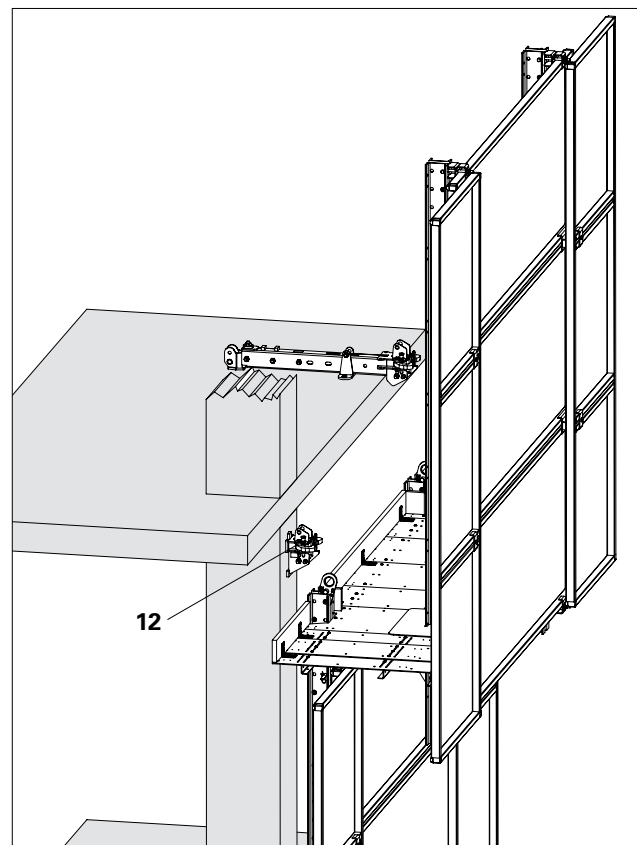

Fig. B1.24

Suspension for Corner Area

The Slab Shoe Corner-2 LPS (11) is positioned on elevated brackets. This allows lateral mounting across another slab shoe.

(Fig. B1.25)

The Slab Shoe Corner-2 LPS is not height adjustable. Adjust the unit alignment on the corresponding second slab shoe of the climbing unit.

Components

- | | |
|-----------|---------------------------|
| 2 | Climbing Rail-2 LPS |
| 10 | Slab Shoe-2 LPS 1* |
| 11 | Slab Shoe Corner-2 LPS 1* |

With the Slab Shoe Corner-2 LPS, the Slab Anchor Template-2 LPS cannot be used crosswise.

Leading Anchor is mounted using on-site measures.

^{1*} All suspension and anchoring parts are safety components.

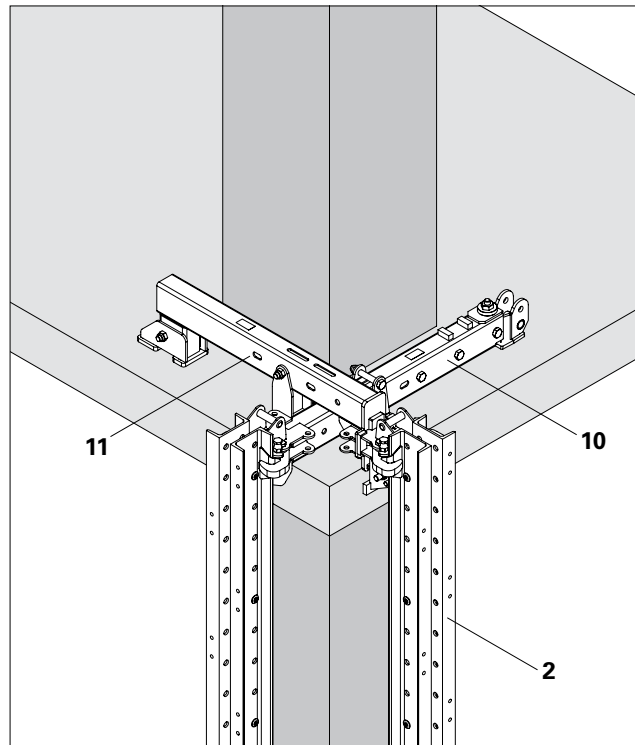

Fig. B1.25

Reaction Forces

Reaction forces

H_1 : Horizontal force on the top slab shoe
(positive: tension, negative: compression)

V_1 : Vertical force on the top slab shoe

H_2 : Horizontal force on the bottom slab shoe (positive: tension, negative: compression)

(Fig. B1.26)

Load cases

see Section "A3 Operating Status and Loads" on Page 18.

A: Working Conditions

Wind load from wind suction with $q = 0.50 \text{ kN/m}^2$ ($v = 100 \text{ km/h}$)
100 % live load on one level; if necessary, 50 % live load on a second level

B1: Storm Conditions

max. wind load from wind pressure $q > 0$
no live loads

B2: Storm Conditions

max. wind load from wind suction $q < 0$
no live loads

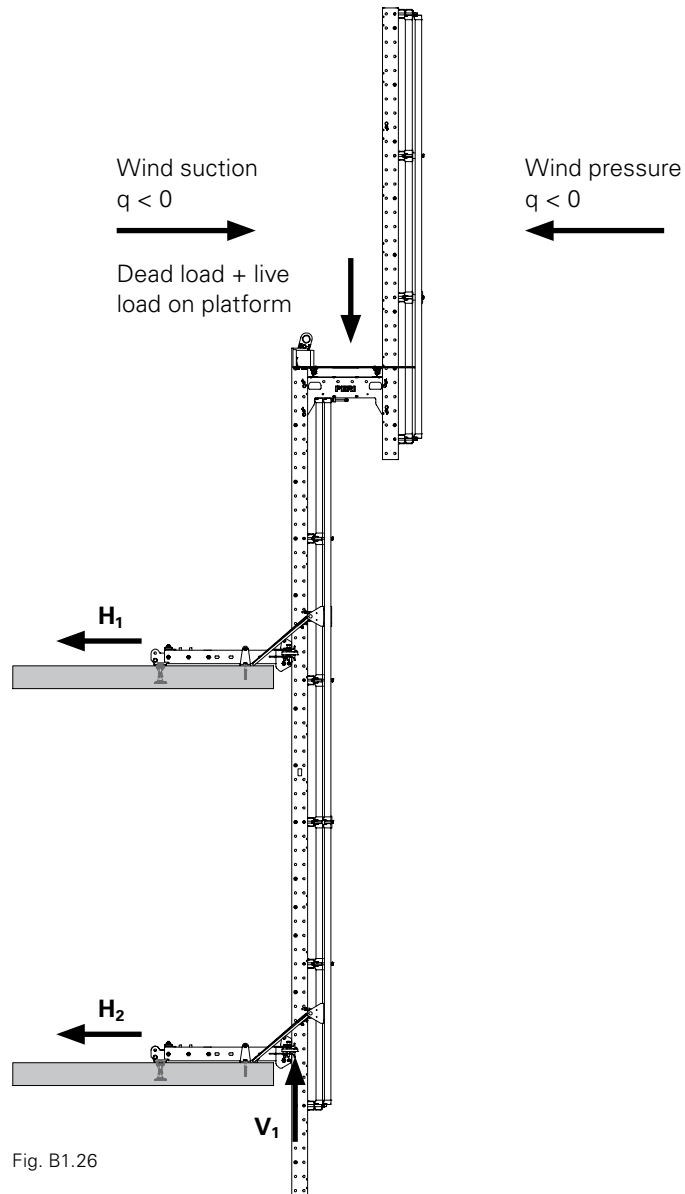

Fig. B1.26

Anchor Forces

H_1 : Horizontal force on the slab shoe
(positive: tension, negative: compression)

V_1 : Vertical force on the slab shoe

Q_A : Anchor shear force

N_A : Anchor tension force

V_C : Support force of the slab
If the concrete slab is not sufficiently stable, then a slab prop, e.g. MULTIPROP, is to be installed under the slab to provide load relief.

(Fig. B1.27)

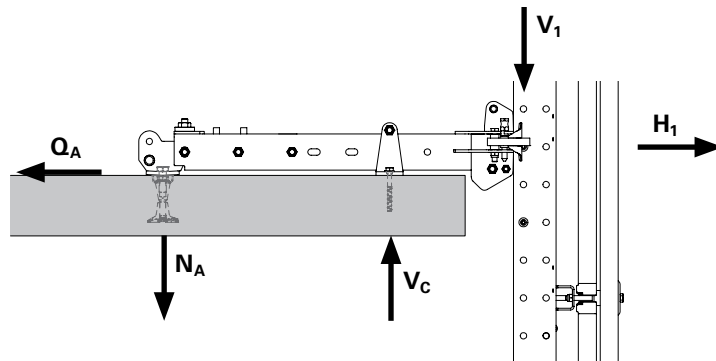

Fig. B1.27



- Due to unscheduled load relief of the slab, slab props already installed can fall over. Secure slab props against falling over especially on the edge of the structure.



Comply with "PERI Design Information LPS Light Protection Screen"!

- The load-bearing capacity of the Slab Shoe-2 LPS and the anchoring must be verified separately.
- The load-bearing capacity of the anchoring depends on the type of anchor, anchoring depth, edge distances and the concrete strength. Deviating conditions may require the installation of additional back-draft reinforcement or reinforcement for the edge surrounding.
- The contractor is responsible for the correct transfer of the reaction forces into the building structure.

General

Observe the following points for planning and the work instructions for the climbing sequence:

- Especially on the corner and internal platforms, the decking is to be installed so that it does not collide with the platforms of adjacent climbing enclosures during the climbing procedure. As a rule, the mitred standard corner solution ensures this.
- If overlapping components are planned between the climbing enclosures, then the climbing sequence is to be planned accordingly and be clearly indicated on the general arrangement drawings. Overlapping components are, for example, covering for the gaps between the climbing enclosures or projecting telescopic screens.
- The gaps between the platforms of the climbing enclosures are to be covered so that they cannot be moved. Remove any fixed covers before climbing and mount again afterwards. However, the elastomer covers of the LPS System can normally remain on the platforms.



Especially for non-symmetrical climbing units, PERI recommends the use of the Lifting Beam 10 t.

- Follow Instructions for Use at all times!
- Ensure loads are evenly balanced when being picked up.

- When climbing by crane, always provide a safe possibility to attach and detach crane lifting gear. Additional double crane slings that remain on the climbing enclosure may be necessary until they can be safely dismantled.
- A hydraulics plan shows how the climbing device with the hydraulic hoses is to be correctly attached to the hydraulic pump.
- Appropriate measures are to be specified regarding safety barriers or guardrails.

Attachment Point for the Crane

The size of the climbing enclosures can be limited by the permissible load of the attachment point on the climbing rail. For this, the weight of the decisive panels is to be determined during the planning phase.

The permissible load of the attachment point is also to be considered for the assembly and dismantling of the climbing enclosures that are to be moved with the self-climbing device.

The weight $G = V_1 + V_2$ of the climbing enclosures is to be specified in the general arrangement drawings. (Fig. B2.01)



For safe attachment and removal of the crane hook or for subsequent installation of compression braces, provide suitable measures to prevent falls.

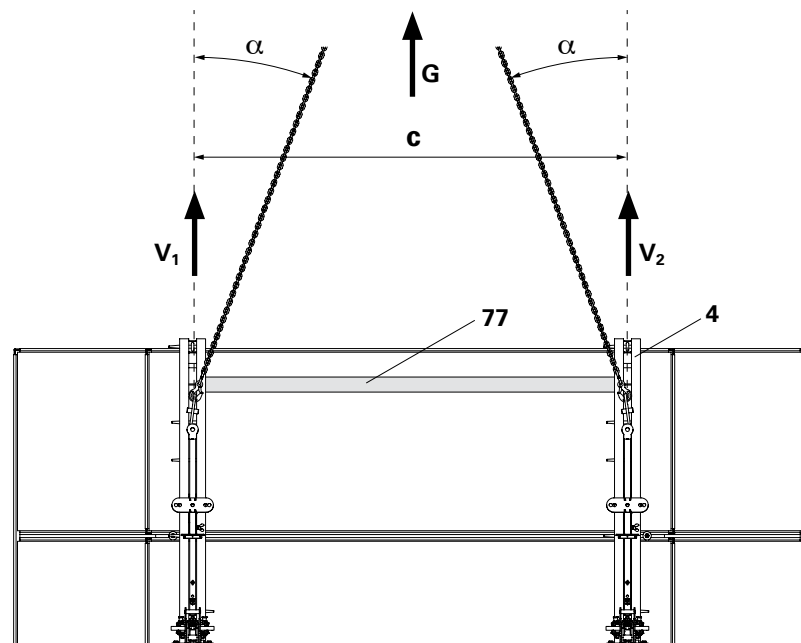

Fig. B2.01

Moving by Crane

Version 1

- Mount Crane Eye BR 2.5 t (7) with Spacer LPS 52 (2.1) max. 2 m above the assembly area.
- Mount one timber 120/100 mm (77) above the Crane Eye between the climbing rails (4) as a compression brace.
- Positional stability of the timber by means of Hex. Wood Screws DIN 571 8x160 (80) and Washers ISO 7094-8, 2x per side. (Fig. B2.02)

Version 2

- Mount Crane Eye BR 2.5 t (7) with Spacer LPS 52 (2.1) at the top end of the climbing rail (4). (Fig. B2.03)
- For setting up after assembly, use a traverse and attach to the enclosure post.



For climbing with a hydraulic self-climbing device or traverse, compression braces are only required for suspension on the building.

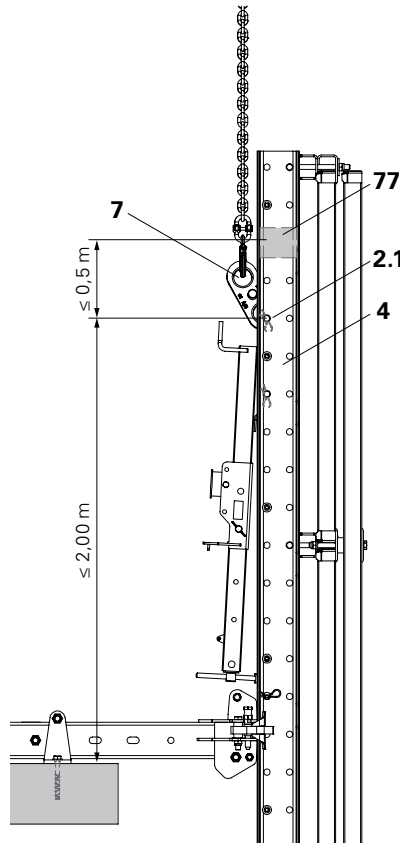

Fig. B2.02

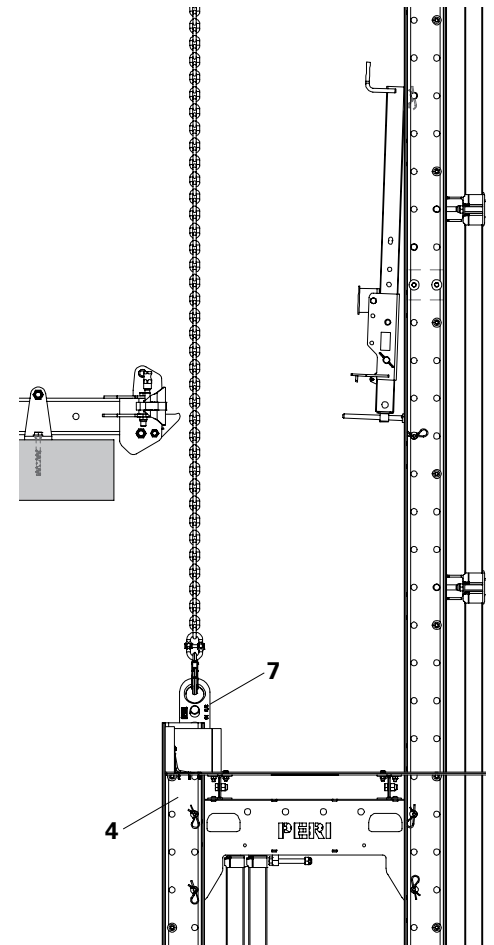

Fig. B2.03

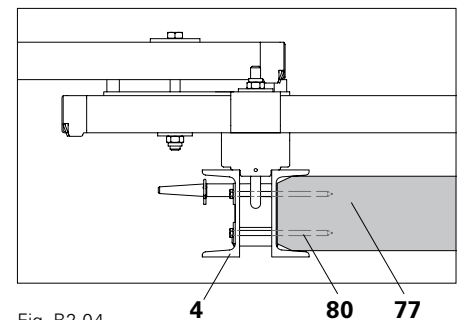

Fig. B2.04

Notes	
Load-bearing capacity per Crane Eye BR-2	$V \leq 25 \text{ kN} \approx 2500 \text{ kg}$
Crane sling angle	$\alpha \leq 30^\circ$
Distance to the compression brace	$\leq 500 \text{ mm}$
Timber 100/120 mm	Bracket spacing $c \leq 4.375 \text{ m}$
Mount attachment points max. 2.0 m above the erection area.	

Table B2.01

Platform Cantilever Beam and Platform Decking

Platform decking

Load Class 2 working scaffold corresponding to DIN EN 12811-1, max. load 150 kg/m².

Pre-assembled platforms (33) are bolted to the Platform Beam (34) with Bolts M10x25 (73) and Nuts (73.1) on the Platform Cantilever Beam LPS (32) (2x per Platform Cantilever Beam).

Platform Cantilever Beam LPS (32) and mounted platform (33) are bolted to the Climbing Rail (2) and Enclosure Post (4) with Fitting Pins Ø 21x120 (81) and Cotter Pins 4/1 (86). (Fig. B2.05)

Assembly of platform (33) and Platform Cantilever Beam (32) takes place during pre-assembly. Platform extensions, consisting of Platform Beam LPS (34) and Platform Cover LPS (35), are only installed on the construction site.



When using planking with a lower strength class or plywood sheets,
 – a more exact static proof is required!
 – other mounting bolts M10 are to be used.

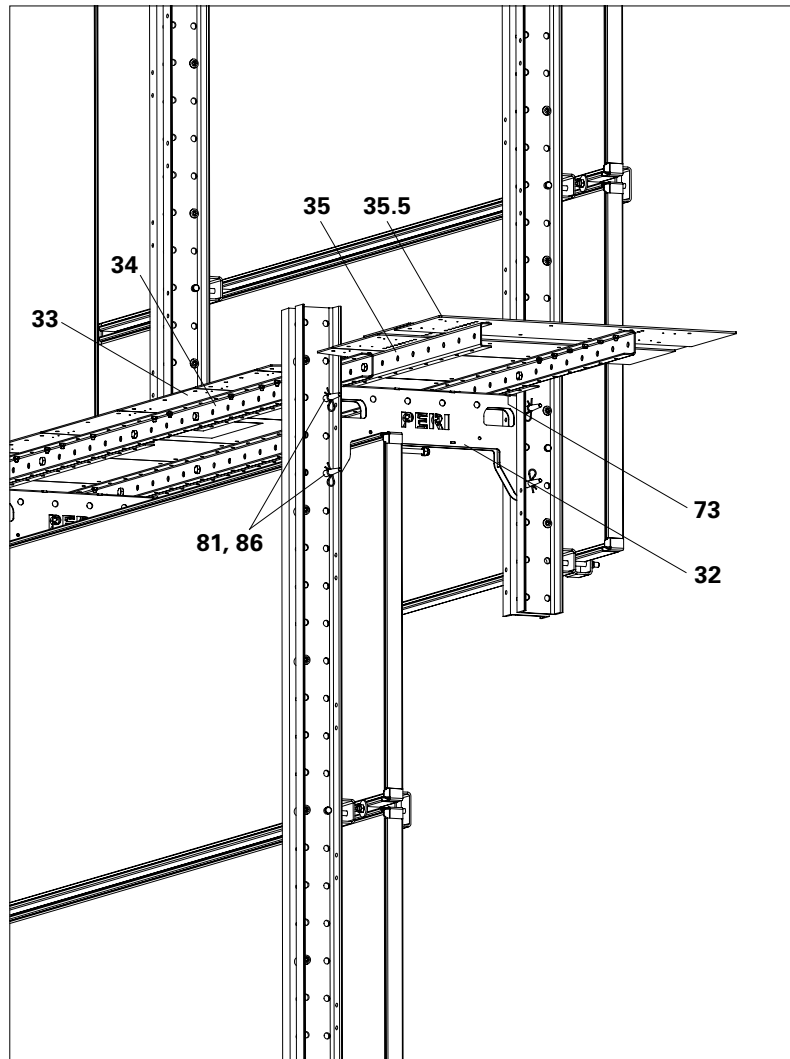

Fig. B2.05

View from below

Components

- 32** Platform Cantilever Beam LPS
- 33** Platform LPS
- 34** Platform Beam LPS
- 35** Platform Beam LPS
- 35.5** Platform Cover LPS 37.5 x 107.5
- 73** Oval-Head Screw ISO 7380
M10x25-10.9
- 73.1** Nut ISO 7040 M10-8
- 81** Fitting Pin Ø 21x120
- 86** Cotter Pin 4/1

Toe Boards

Toe Boards (37) made of solid wood C24 (softwood S10) Minimum dimensions $b/d = 3/15$ cm.

Mounting with Toe Board Angle 90° (82).

For platform extensions, pre-drill with $\varnothing 5$ mm the Platform Covers (35.5) in order to screw on the Angle Connectors. Secure Angle Connector to Platform Cover using SPAX 6 x 20.

Mount Toe Boards to Angle Connectors using SPAX 5x30.

Fix Toe Boards to corner connections with TSS Torx 6x60. (Fig. B2.06)

Components

- | | |
|-------------|---------------------------------|
| 33 | Platform LPS |
| 35.5 | Platform Cover LPS 37.5 x 107.5 |
| 37 | Toe Board |
| 82 | Toe Board Angle 90° |
| 83 | SPAX 6x20 TX30 |

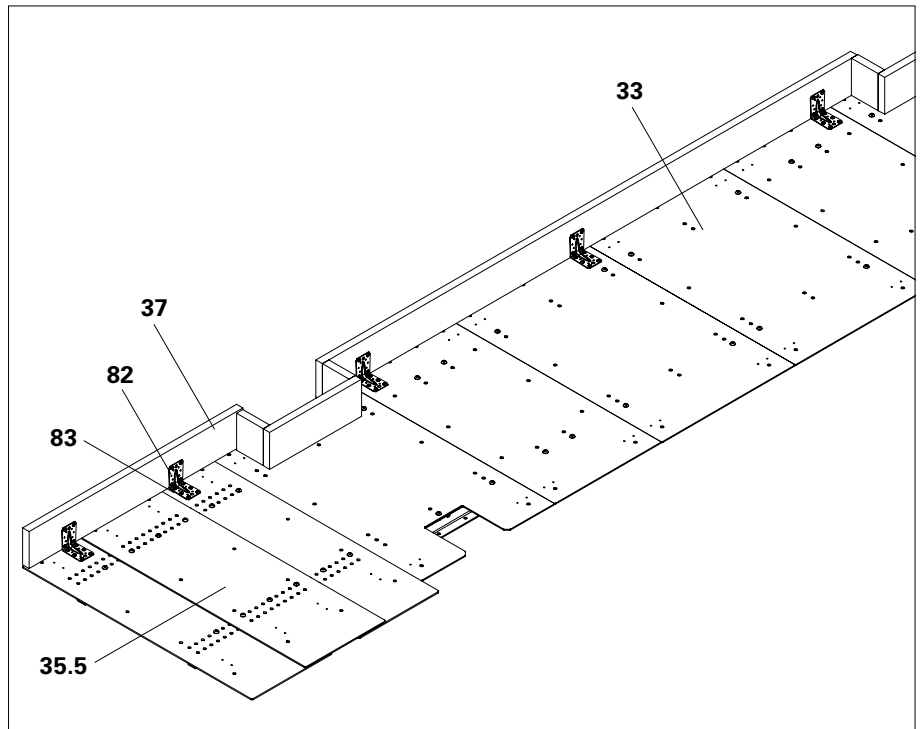

Fig. B2.06

Platform Extension

Platform extensions are required, e.g. when using Telescopic Screens.

Platform extension with 2 Platform Beams

The Platform Beams (34) for platform extensions are bolted to the available Platform Beam (35) using Bolts (72) and Nuts (72.1) (4x per platform extension).

(Fig. B2.07)

Permissible cantilever with 2 Platform Beams	
Bracket spacing c	Permissible cantilever d
1.875 m	1.500 m
2.375 m	1.563 m
2.875 m	1.500 m
3.750 m	1.375 m
4.375 m	1.313 m

Table B2.02



Minimum spacing of bolts $S \geq 250$ mm.

Working platform load according to Scaffold Group 2:

Max. live load 150 kg/m^2

with single loads of

150 kg, distributed over area 50×50 cm,

or 100 kg, distributed over area 20×20 cm.

Components

- 34** Platform Beam LPS 123 or 173
- 35** Platform Beam LPS
- 35.5** Platform Cover LPS 37.5×107.5
- 72** Bolt ISO 4017 M16x40-8.8
- 72.1** Nut ISO 7040 M16-8

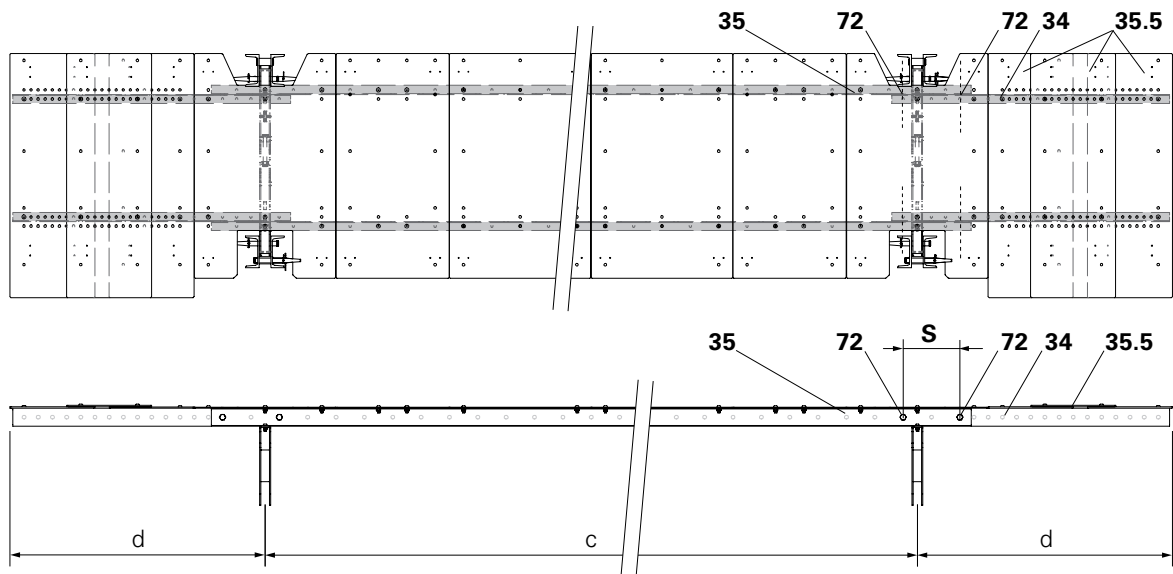

Fig. B2.07

Reinforced platform extension with 3 Platform Beams

For a reinforced design with 3 Platform Beams, the permissible cantilever d is increased. See Table 5.

The additional Platform Beams (34a) are mounted centrally between the available Platform Beams (34).

All three Platform Beams are bolted to two timbers (76) as trimmer using Bolts M8x100 (78).

(Fig. B2.08)

Permissible cantilever with 3 Platform Beams	
Bracket spacing c	Permissible cantilever d
1.875 m	1.500 m
2.375 m	1.781 m
2.875 m	1.719 m
3.750 m	1.625 m
4.375 m	1.563 m

Table B2.03



Minimum spacing $x > d \times 0.5$

Components

- 34** Platform Beam LPS
- 34a** Platform Beam LPS 235 or 285
- 35.5** Platform Cover LPS 37.5 x 107.5
- 76** Timber 80/80 mm, length 0.80 m
- 78** Flat Round Screw DIN 603
M8x100 MU

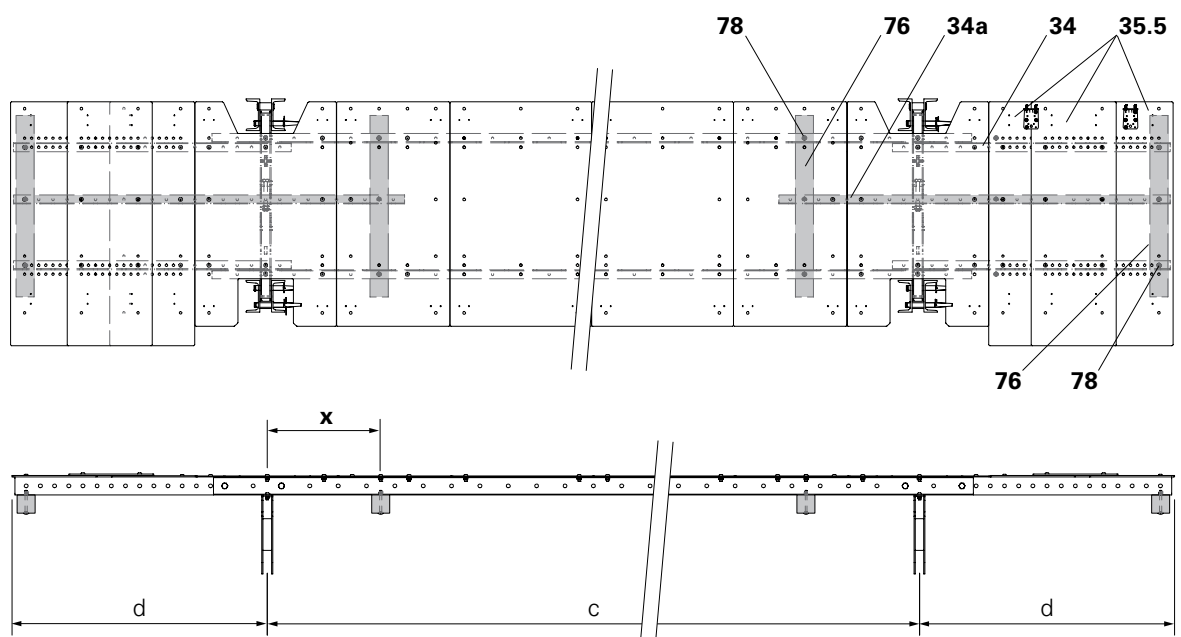

Fig. B2.08

Mitred platform corner solution

The mitred standard corner solution with Platform Cover Corner LPS 105 x 105 (36.4) can be designed up to a max. bracket distance of $c = 4.375$ m.

Connect Platform Beams LPS 123 (34.2) with Bolt M16x40 (72) and Nuts (72.1) (2x each), minimum spacing $S = 250$ mm.

Fix Platform Cover Corner with Oval-Head Screws ISO 7380 M10x25-10.9 (73) and Nuts M10 (5x) to Platform Beam. (Fig. B2.09)



Minimum spacing $S = 250$ mm.

Components

- 34.2** Platform Beam LPS 123
- 36.4** Platform Cover Corner LPS 105 x 105
- 72** Bolt ISO 4017 M16x40-8.8
- 72.1** Nut ISO 7040 M16-8
- 73** Oval-Head Screw ISO 7380 M10x25-10.9
- 73.1** Nut ISO 7040 M10-8

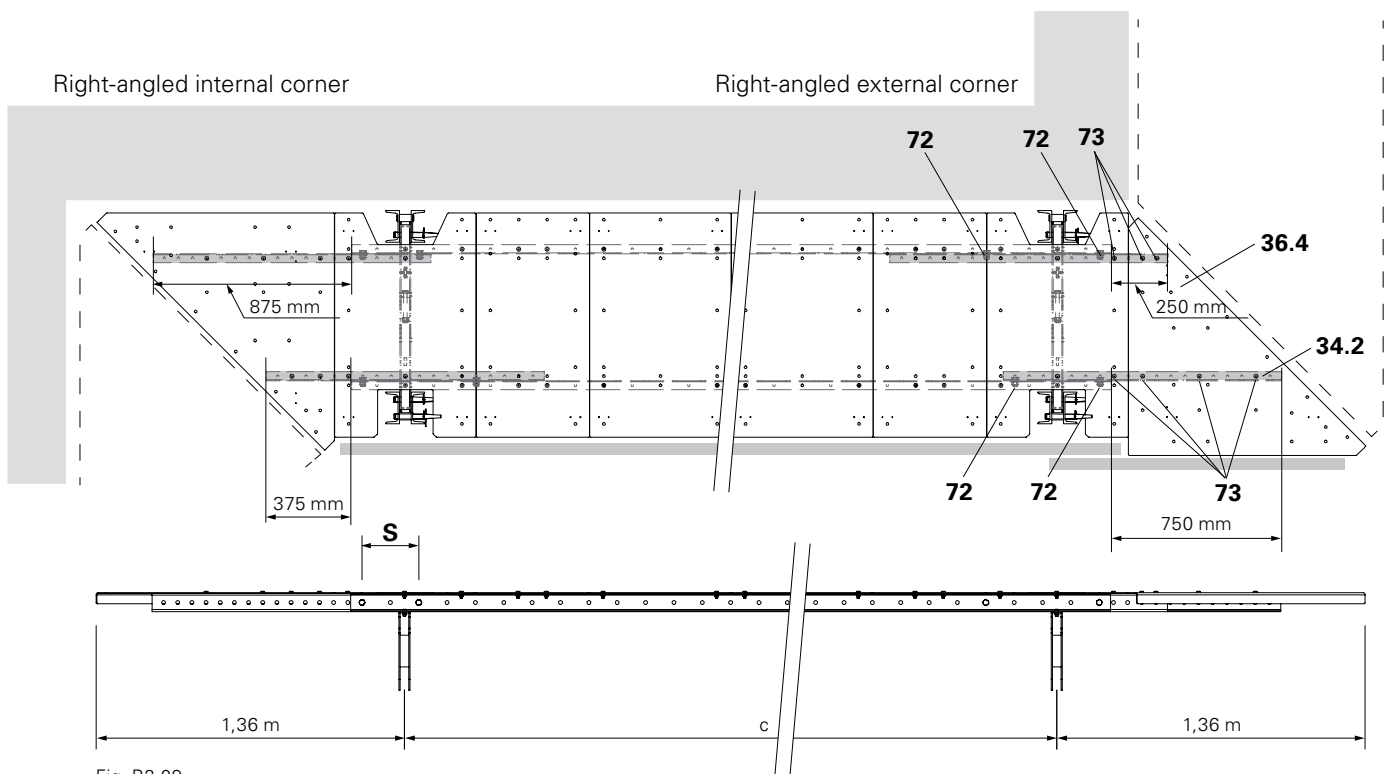

Fig. B2.09

Protection against Falling Objects

The enclosure and platforms should completely enclose the working area. Basically, openings > 20 mm in the area of risk are to be covered in a non-displaceable manner.



- Setting down and storage of material and tools on the coverings is prohibited.
- Foldable covers are not decking surfaces and are planned as areas not to be walked on or subject to loads.
- Take into account the fibre direction F of the surface layer! (Fig. B2.11)

Securing the slab edge

In the area of the floor slabs, fix the scaffold tubes (43) to the Climbing Rail by means of clamps (74) or scaffold tube holders (46) and nuts.

For Telescopic Screens, extend the scaffold tube with a telescopic tube (44).

Create foldable covers (40) consisting of untreated plywood (79) with Flap Hinges (41), and mount.

In order to prevent unintentional detachment, install a flap safety device (42) in the centre. (Fig. B2.10 + B2.11)

Components

2	Climbing Rail-2 LPS
40	Foldable Cover
41	Flap Hinge LPS Ø 48/M10
42	Flap Safety Plate LPS Ø 48
43	Scaffold Tube Ø 48.3 x 3.2
44	Telescopic Scaffold Tube LPS
44.1	Clip M10
46	Scaffold Tube Connector Ø 48-M10 LPS
74	Clamp A64 DIN 3570 M12
74.1	Nut ISO 4032 M12-8
79	Untreated Plywood 20, 21 mm

Flap material:	Untreated plywood ≥ 20 mm
Permissible inclination:	10° – 30°
Permissible depth:	≤ 0,75 m
Hinge spacing:	≤ 1.20 m, minimum 2 hinges per flap
Hinge spacing to Clip M10 (44.1):	≤ 10 cm
Hinge spacing to Climbing Rail (2):	≤ 20 cm

Table B2.04

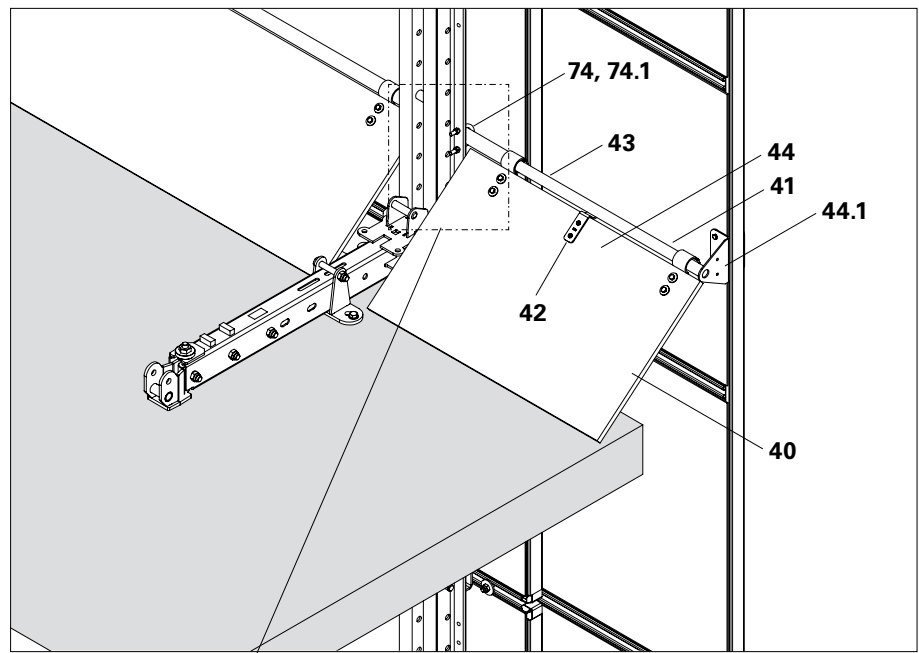

Fig. B2.10

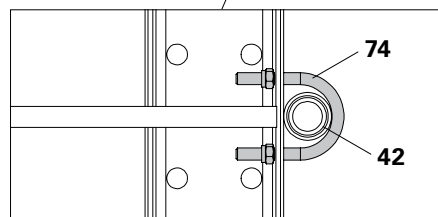

Fig. B2.10a

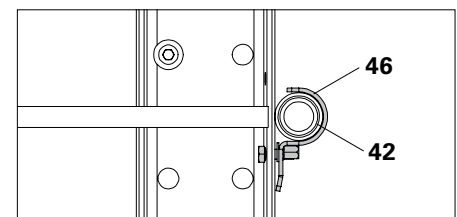

Fig. B2.10b

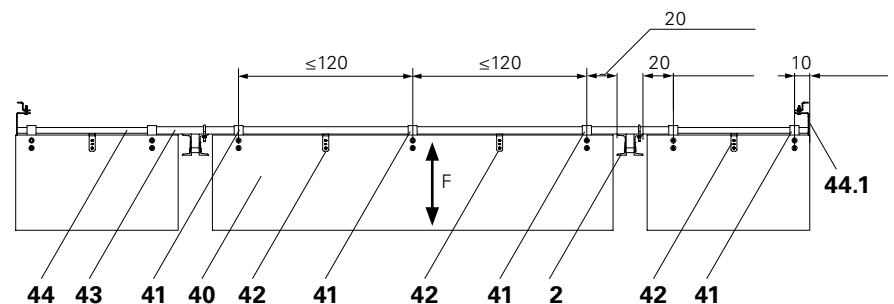

Fig. B2.11

Closing gaps

Close the gap in the area of the Climbing Shoe with Cover Mat (60). Cover gaps on flaps between climbing units by means of Cover Strips (61) that are screwed on.
(Fig. B2.12)

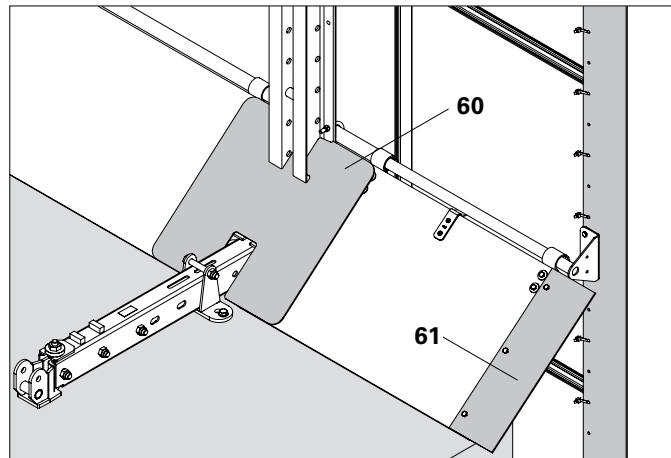

Fig. B2.12

Close the gap at the enclosure post (Climbing Rails LPS or Steel Waler SRU) with Cover Mat (61.1).
(Fig. B2.13)

Cover the gaps between the platforms and the mesh enclosure, which have been created between the climbing enclosures, with elastomer Cover Strips (61). Cable binders are used for fixing on the mesh of the Screen Elements.
(Fig. B2.13)



PERI recommends a distance between the climbing units c_c of 50 mm.

Components

60	Cover Mat LPS 60 x 75 U140
61.1	Cover Mat LPS 41 x 66
61	Cover Strip LPS 0.20 x 10 m
73	Oval-Head Screw ISO 7380 M10x25-10.9
73.1	Nut ISO 7040 M10-8
75	Cable Binder PA 6.6 SW 203x7.6

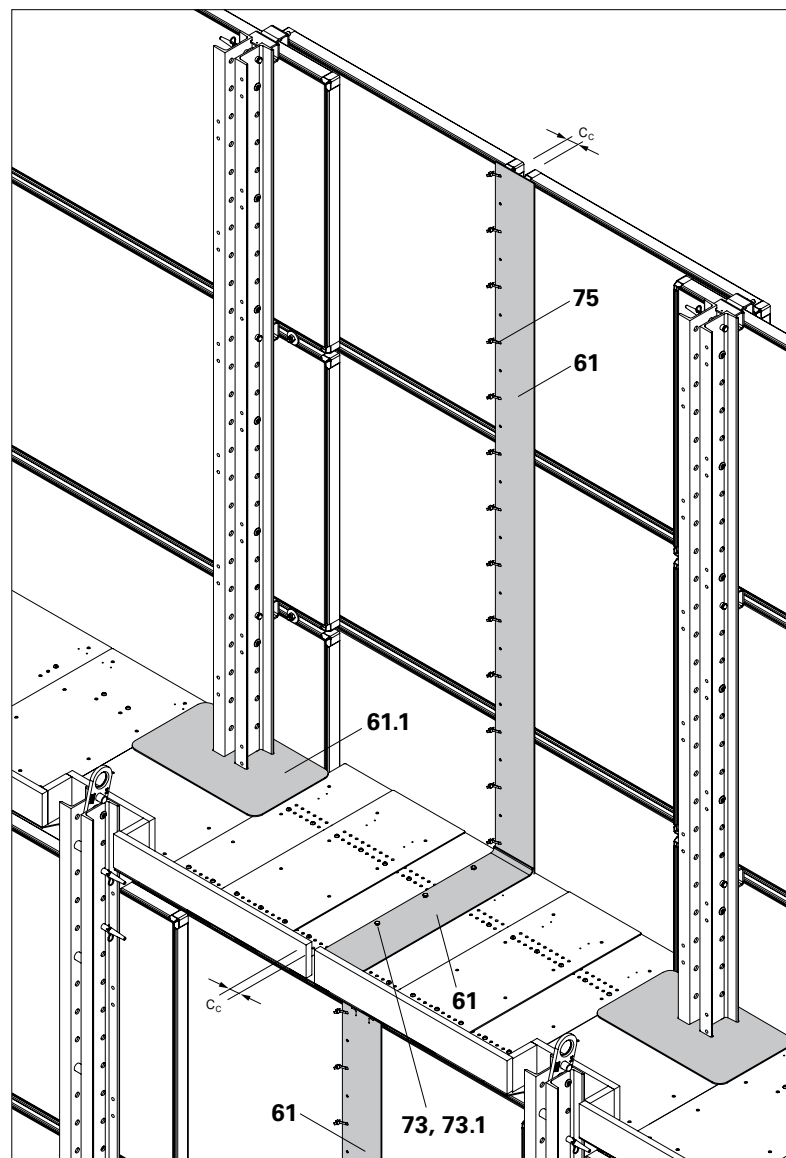

Fig. B2.13

Covering with Finishing Platform

Instead of foldable covers, Trailing Platforms LPS can be mounted for securing the gap between the enclosure and the slab edge.



Version 1 + 2

For the climbing enclosure with working platform, without cantilevered slab shoe, the gap is completely covered by the trailing platform.

Securing the slab edge

Mount Support Angle (51) on the Telescope Beam by means of bolts (72) and nuts (72.1) and pins (57) and cotter pins (86).

Attach Platform Cover Trailing Platform LPS (53, 54) to the Support Angle (51) using oval-head screws (73).

When enclosing with the Telescopic Screens, extend the telescopic tubes (50.1) and close the gap with Support Angles and Platform Cover LPS 92.

For Telescopic Screens that are only partially extended, close the gap with cut-to-size untreated plywood and screwed on Cover Strip LPS 0.20 x 10 m.

(Fig. B2.14a)

The Platform Cover Trailing Platform (55, 56) can only be mounted on a retracted telescopic tube (50.2). (Fig. B2.14)

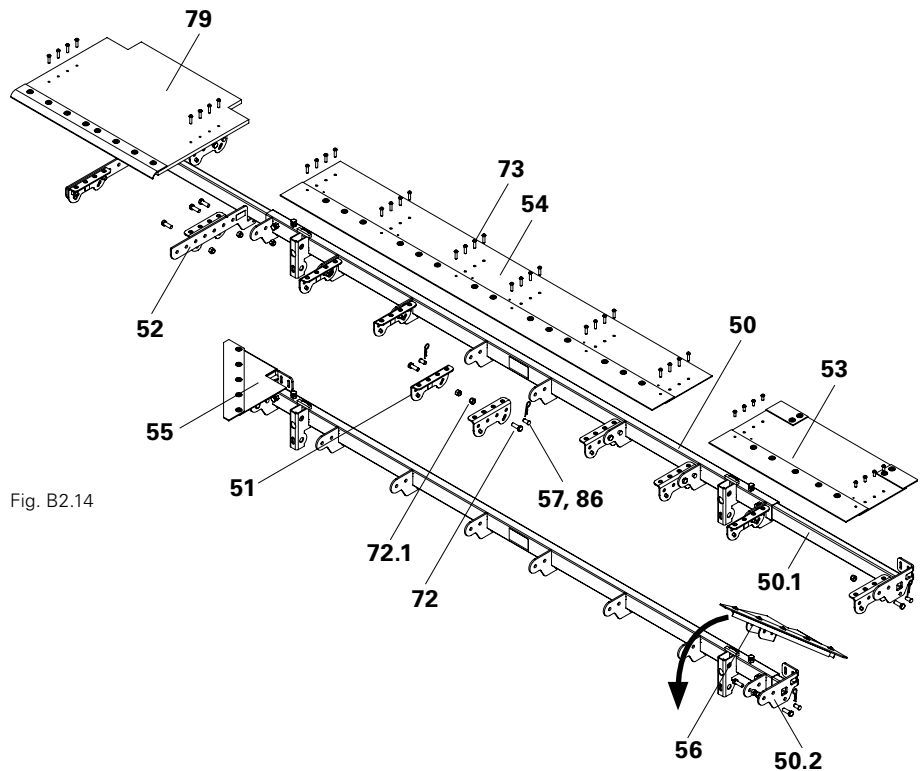

Fig. B2.14

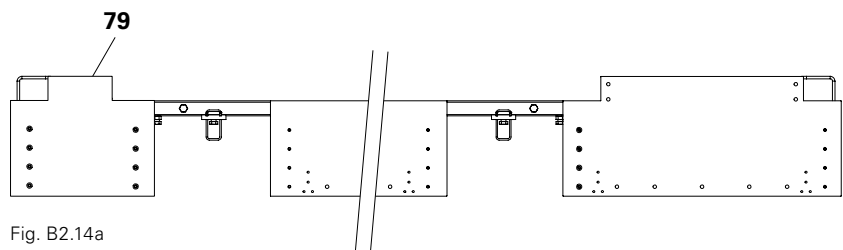

Fig. B2.14a

Components

- 50** Telescope Beam Trailing Platform LPS
- 51** Support Angle TP LPS 25
- 52** Cantilever TP LPS 57
- 53** Platform Cover TP LPS 92
- 54** Platform Cover Trailing Platform LPS
- 55** Corner Cover Trailing Platform LPS, left
- 56** Corner Cover Trailing Platform LPS, right
- 57** Bolt Ø 16x36
- 72** Bolt ISO 4017 M16x40-8.8
- 72.1** Nut ISO 7040 M16-8
- 73** Oval-Head Screw ISO 7380 M10x25-10.9
- 73.1** Nut ISO 7040 M10-8
- 79** Untreated Plywood 20, 21 mm
- 86** Cotter Pin 4/1

Closing gaps

Close the gap at the enclosure post (Climbing Rails LPS or Steel Waler SRU) with Cover Mat.

Version 1

For the climbing enclosure with straight, continuous screen elements, additional foldable covers are required due to the cantilevered slab shoe.

Cut the untreated plywood to size and fix to the Platform Cover (53, 54) with Cover Strip LPS 0.20 x 10 m (61) of with hinges (85).

Close the remaining gap at the slab shoe with Cover Mat LPS 41 x 61. (Fig. B2.15)

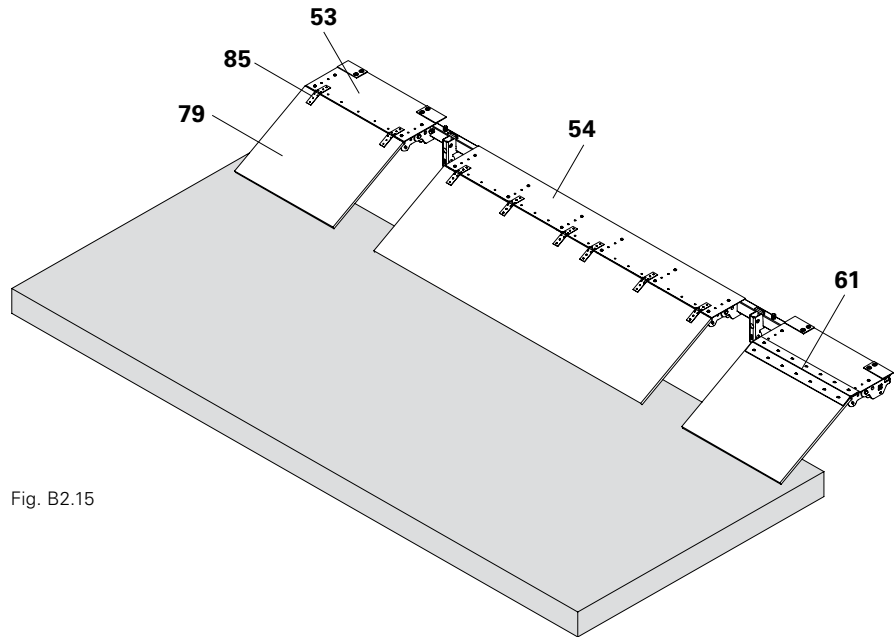

Fig. B2.15

Components

53	Platform Cover TP LPS 92 LPS 92
54	Platform Cover Trailing Platform LPS
61	Cover Strip LPS 0.20 x 10 m
79	Untreated Plywood 20, 21 mm
85	Hinge DIN 7957-200

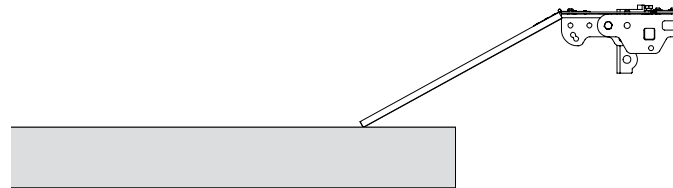

Fig. B2.16

Version 2

For climbing enclosures with working platforms, completely foldable covers are required due to the small distance to the structure.

Mount the Supporting Angle (51) and Kicker (52) on the telescopic tube. Cut untreated plywood to size and screw onto the Supporting Angle by means of oval-head screws (73.1) as a platform covering.

Fix untreated plywood with hinges (85) to the Platform Cover (53) as a rear flap (79a).

Fix untreated plywood with Cover Strip LPS 0.20 x 10 m (61) to the Platform Cover (53) as a front flap (79b). (Fig. B2.17)

Close the remaining gap at the slab shoe with Cover Mat LPS 41 x 61 and Cover Strip.

For climbing, first fold up the rear flap and then the front flap. Finally, completely fold up the cover unit. (Fig. B2.17a)

Components

- | | |
|-------------|---|
| 51 | Support Angle TP LPS 25 |
| 52 | Cantilever TP LPS 57 |
| 61 | Cover Strip LPS 0.20 x 10 m |
| 77 | Oval-Head Screw ISO 7380
M10x40-10.9 |
| 73.1 | Nut ISO 7040 M10-8 |
| 79 | Untreated Plywood 20, 21 mm |
| 85 | Hinge DIN 7957-200 |

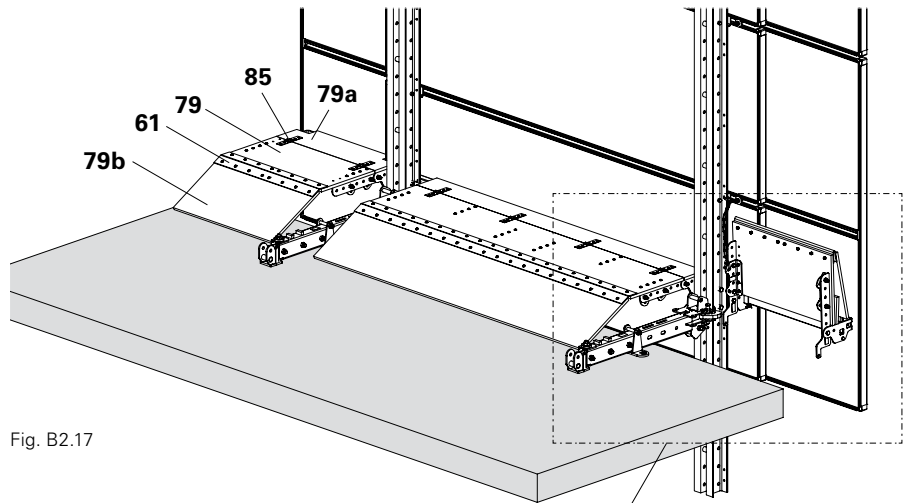

Fig. B2.17

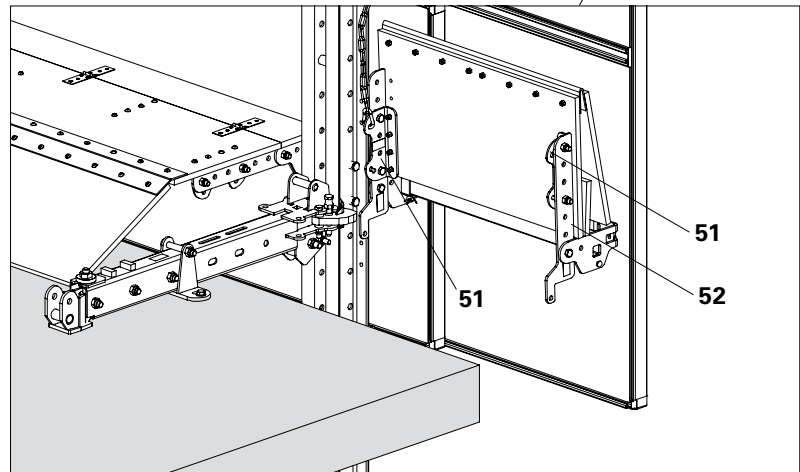

Fig. B2.17a

Enclosure without Telescopic Screen

The enclosure and screen elements should completely enclose the working area.

Fixing the enclosure screens

Fix Screen Element (21) with Screen Adapter LPS (24, 25).

Fix Screen Adapter Single LPS (24) and Screen Adapter Double LPS (25) to the enclosure post or Climbing Rail using Fitting Pins (81) and Cotter Pins 4/1 (86). (Fig. B2.18)

Alternative:

Fix with Bolts M20 x 90-8.8 (87) and Nuts M20-8.

Fixing the enclosure screen to the Platform Cantilever Beam.

Thread the screen elements (21) on to the Platform Cantilever Beam (32) and secure with adjusting bolt (32.1); see Section "Assembly of the Screen Elements and Telescopic Screens" on Page 78. (Fig. B2.18)

Components

2	Climbing Rail-2 LPS 998
4	Climbing Rail-2 LPS 398
21	Screen Element DX LPS
24	Screen Adapter Single LPS 60
25	Screen Adapter Double LPS 60
32	Platform Cantilever Beam LPS
81	Fitting Pin Ø 21x120
86	Cotter Pin 4/1
87	Bolt ISO 4014 M20 x 90-8.8
88	Nut ISO 7042 M20-8

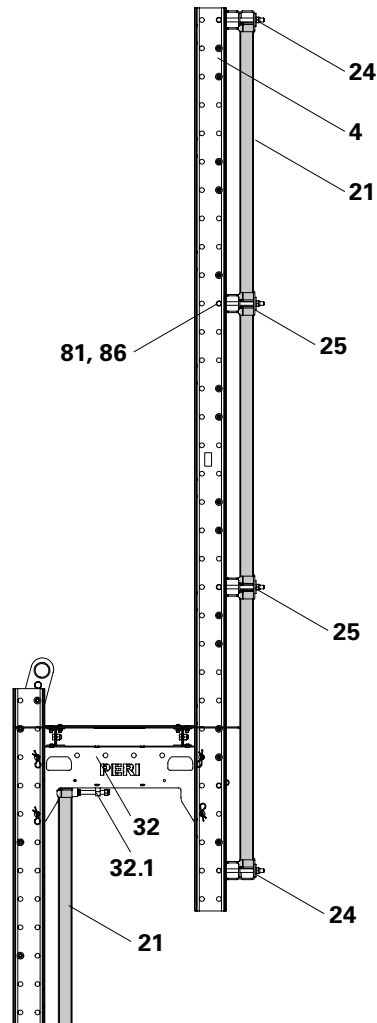

Fig. B2.18

Fixing the Telescopic Screen:

Mount the Telescopic Screen (22) with Screen Adapter Telescope (26) on the Screen Element (21). Tightening torque of the clamping screws = 80 Nm.

The Screen Elements (21) are mounted on the Climbing Rail by means of Screen Adapter Single and Double.

For cantilevers up to max. 1,055 mm. (Fig. B2.19)

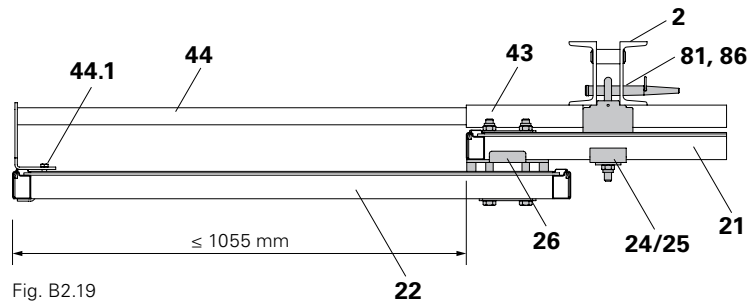

Fig. B2.19

Alternative:

Fixing the Screen Element (21) and Telescopic Screen (22) to the Climbing Rail with the Screen Adapter Combi (27).

Screen Adapter Double and Screen Adapter Telescope are replaced by the Screen Adapter Combi.

Fix Screen Adapter Combi (27) to the Climbing Rail-2 LPS by means of Fitting Pins (81) and Cotter Pins (86) or alternatively with Bolts M20 x 90-8.8 and Nuts M20-8.

For cantilevers up to max. 870 mm. (Fig. B2.20)

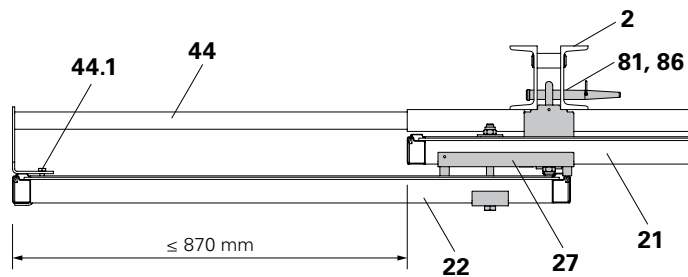

Fig. B2.20

For mounting the foldable covers: insert a telescopic tube (44) into the scaffold tube (43) and, on the other side, secure with Clip M10 (44.1) on the Telescopic Screen (22) through the wire mesh.

Components

2	Climbing Rail-2 LPS
21	Screen Element DX LPS
22	Telescopic Screen DX LPS
24	Screen Adapter Single LPS 60
25	Screen Adapter Double LPS 60
26	Screen Adapter Telescope-2 LPS
27	Screen Adapter Combi LPS 60
43	Scaffold Tube Ø 48.3 x 3.2
44	Telescopic Scaffold Tube LPS
44.1	Clip M10
81	Fitting Pin Ø 21 x 120
86	Cotter Pin 4/1

Screen Adapter Corner LPS

For fixing Telescopic Screens LPS at right angles to other screen elements. Assembly of the Screen Adapter Corner LPS takes place with the Screen Anchor Plate (28.1), nuts and counter nuts on the double strut of the Telescopic Screen (22) or on the struts of two adjacent standard Screen Elements. (Fig. B2.21)

Edge Screen Adapter Telescope LPS

With increased wind loads, mount the Edge Screen Adapter Telescope LPS (29) across the top and bottom sides of the Telescopic Screen (22) and Screen Element (21).

Hand-tighten clamping screws to the screen.

(Fig. B2.22 + B2.22a)

Edge Screen Adapter Corner LPS

When forming corners, mount the End Screen Adapter Corner LPS (30) on the top and bottom sides of the Telescopic Screen.

Hand-tighten clamping screws to the screen.

(Fig. B2.22 + B2.22a)

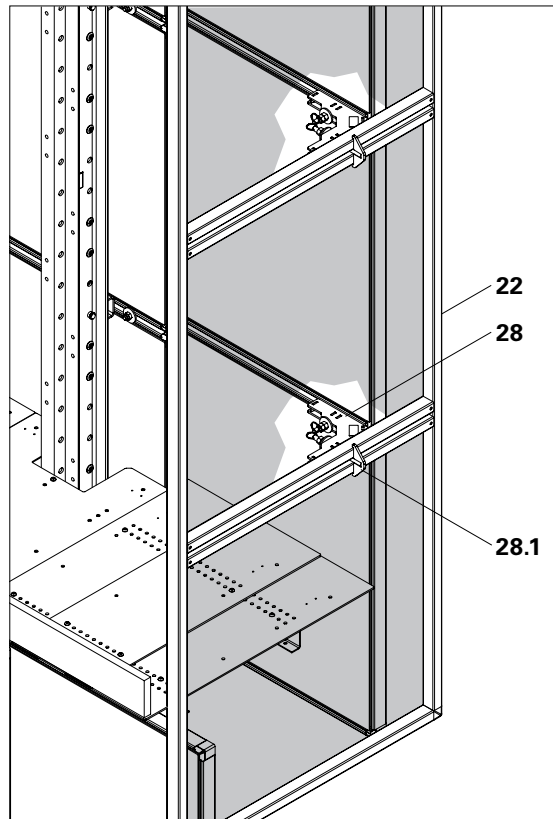

Fig. B2.21



See PERI Design Information Section 3.6 "Telescopic Extension".

Components

21	Screen Element DX LPS
22	Telescopic Screen DX LPS
28	Screen Adapter Corner LPS
28.1	Screen Anchor Plate
29	Edge Screen Adapter Telescope LPS
30	Edge Screen Adapter Corner LPS

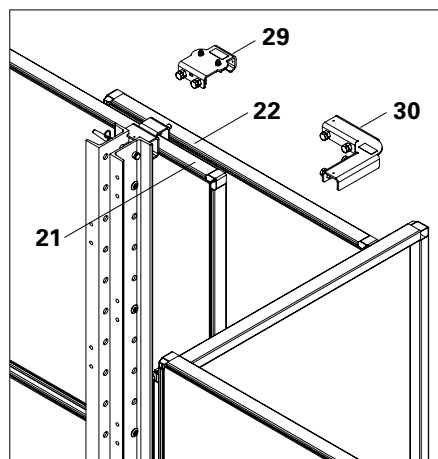

Fig. B2.22

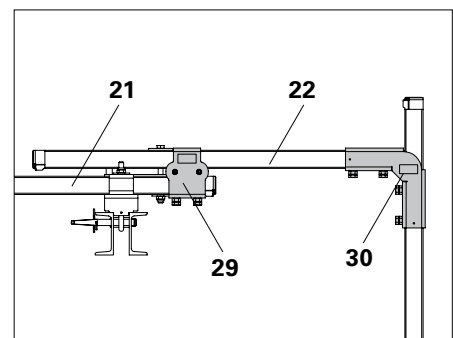

Fig. B2.22a

Vertical Bracing

Depending on the static requirements, horizontal forces can be transferred into the structure using the vertical bracing. This could be, e.g. transverse wind forces acting on the climbing enclosure.

Mount Bracing Chains (8.1) with Bracing Connectors LPS (8) crosswise on projecting Climbing Rail above the top slab shoe.

Pre-tension Bracing Chain with a turnbuckle:

- Oiled turnbuckle: hand-tightened.
- Non-oiled turnbuckle: hand-tightened plus one complete turn (360°).



See PERI Design Information Section 3.3.1 and 3.4.5 "Lateral Bracing"

Components

-
- 8** Bracing Connector LPS
 - 8.1** Bracing Chain LPS 5.0 m
-

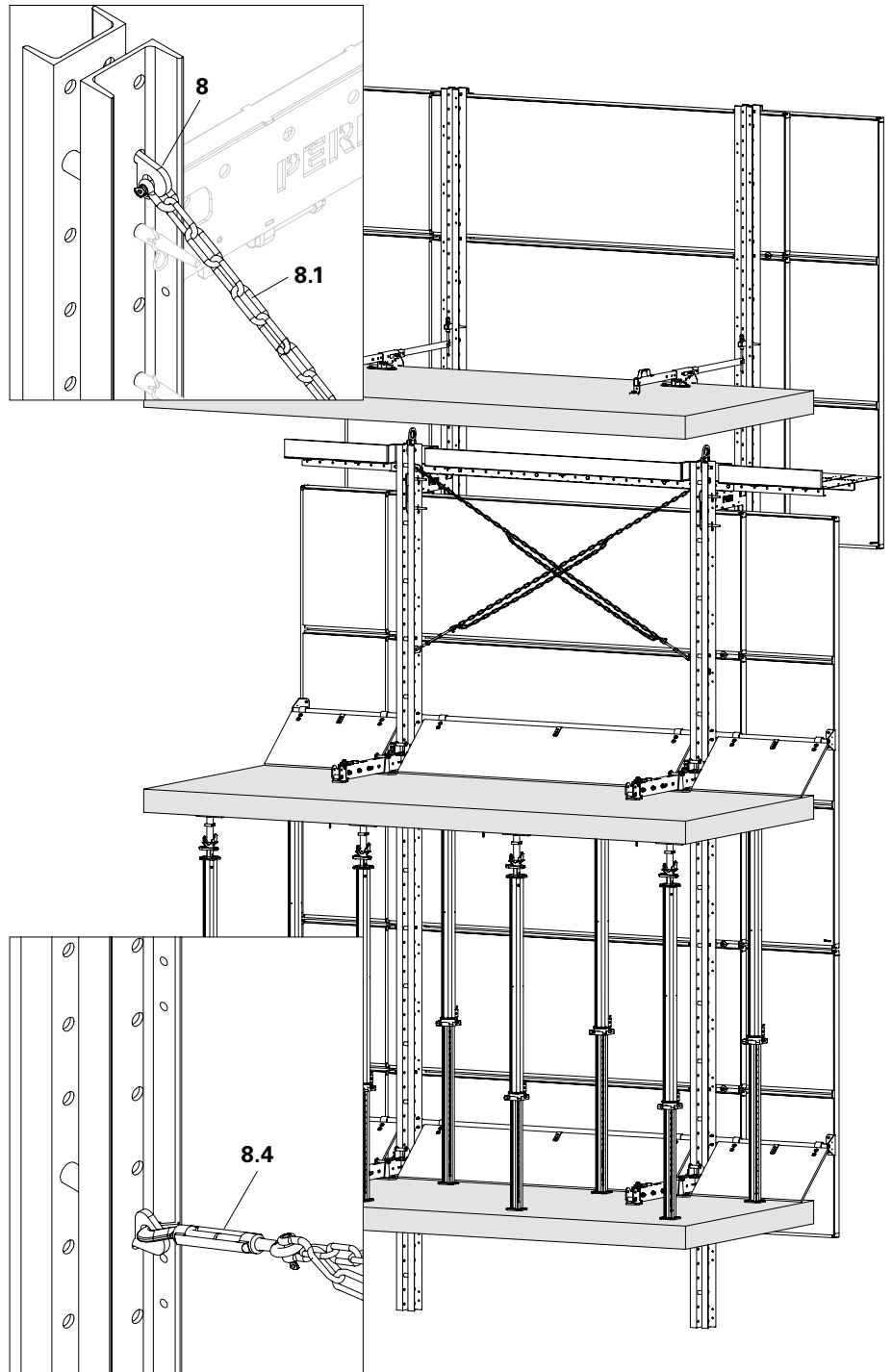

External Corners

When planning all corner solutions ensure that the mesh panel enclosure on the climbing rail does not collide with the platform of the neighbouring unit during climbing.



If there is a risk of the platforms colliding with the mesh panels of the neighbouring unit during climbing, then the climbing sequence has to be specified during planning and has to be pointed out explicitly during the briefing and introduction.

Corner area 90°

Standard corner elements e.g. for internal building columns with an edge distance of $x \geq 400$ mm.

At the corner of the building: a cross-wise arrangement of the Slab Shoe-2 LPS (10) and Slab Shoe Corner-2 LPS (11). (Fig. B3.01a)

For a load-optimised corner solution, arrange the Slab Shoes as close to the building corner as possible.



Going below a lateral edge distance c_2 of 200 mm for the anchoring is not advisable without additional static proof. If necessary, measure and arrange edging reinforcement in the slab.

Components

- | | |
|-----------|------------------------|
| 10 | Slab Shoe-2 LPS |
| 11 | Slab Shoe Corner-2 LPS |

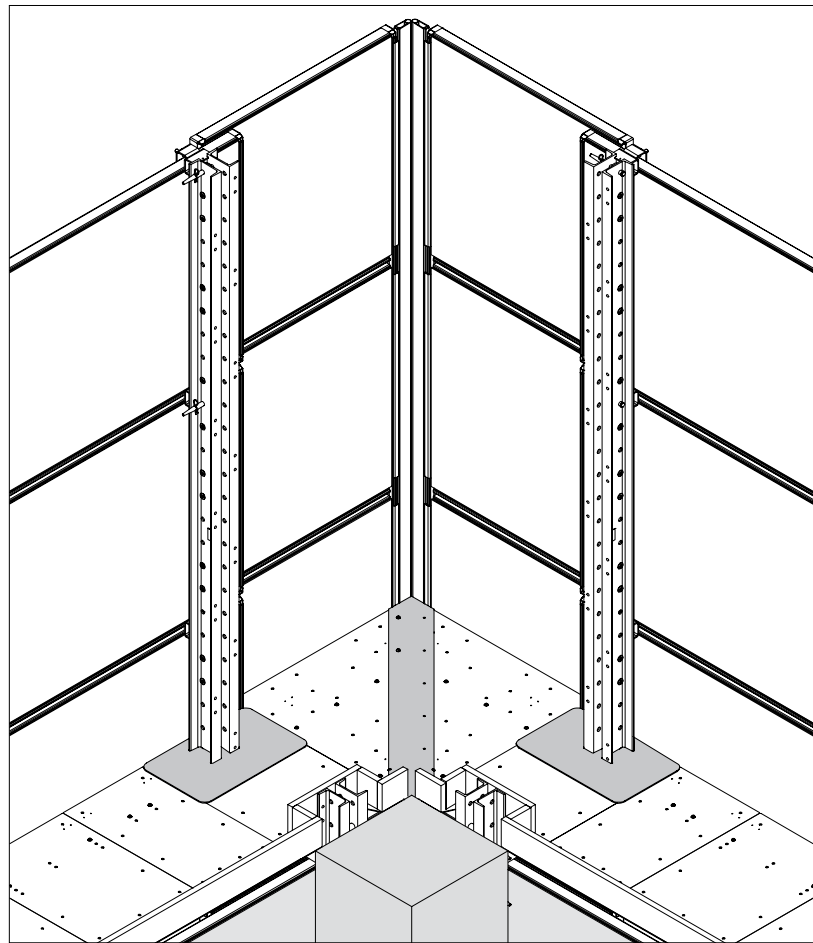

Fig. B3.01

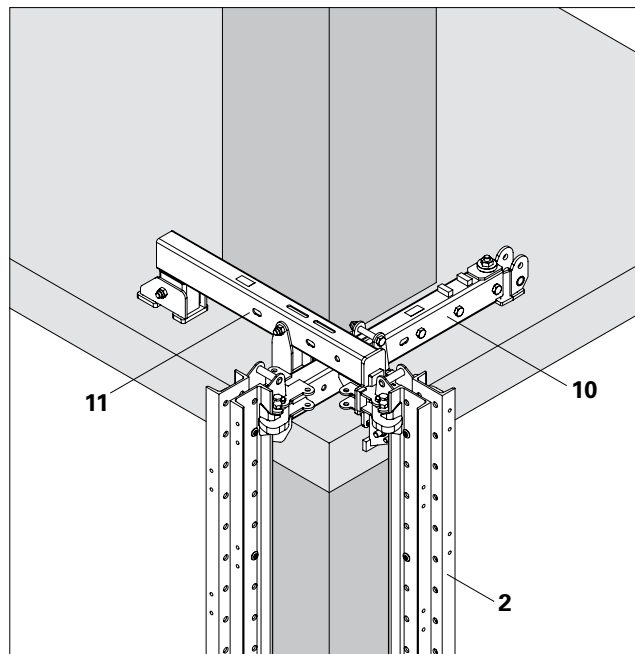

Fig. B3.01a

Version 1: straight

The corner solutions are realised by means of a corresponding cantilevered mesh panel enclosure and, if necessary, by using Telescopic Screens up to the angle bisector (minus a safety clearance of 30 mm).

Cut mitred foldable covers (40) for the external corners.

The foldable covers are attached on both sides, even in the case of small mitred areas.

A safety distance only has to be observed within the mesh panel area. (Fig. B3.02)

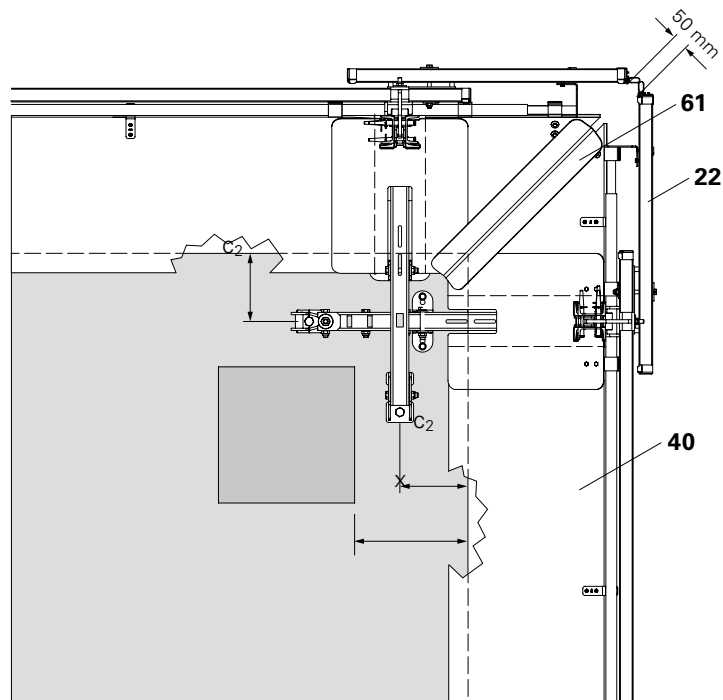

Fig. B3.02

Version 2: with working platform

Standard corner solution with Platform Cover Corner LPS 105 x105 (36.4).

For platforms, maintain a safety distance of min. 50 mm. Cover gap with Cover Strip LPS 20 x 158 (62.1). Fix Cover Strip on one side with Screw M10x25 (73). (Fig. B3.03)

Components

22	Telescopic Screen DX LPS
36.4	Platform Cover Corner LPS 105 x 105
61	Cover Strip LPS 0.20 x 10 m
62.1	Cover Strip LPS 20 x 158
73	Oval-Head Screw ISO 7380 M10x25-10.9
73.1	Nut ISO 7040 M10-8

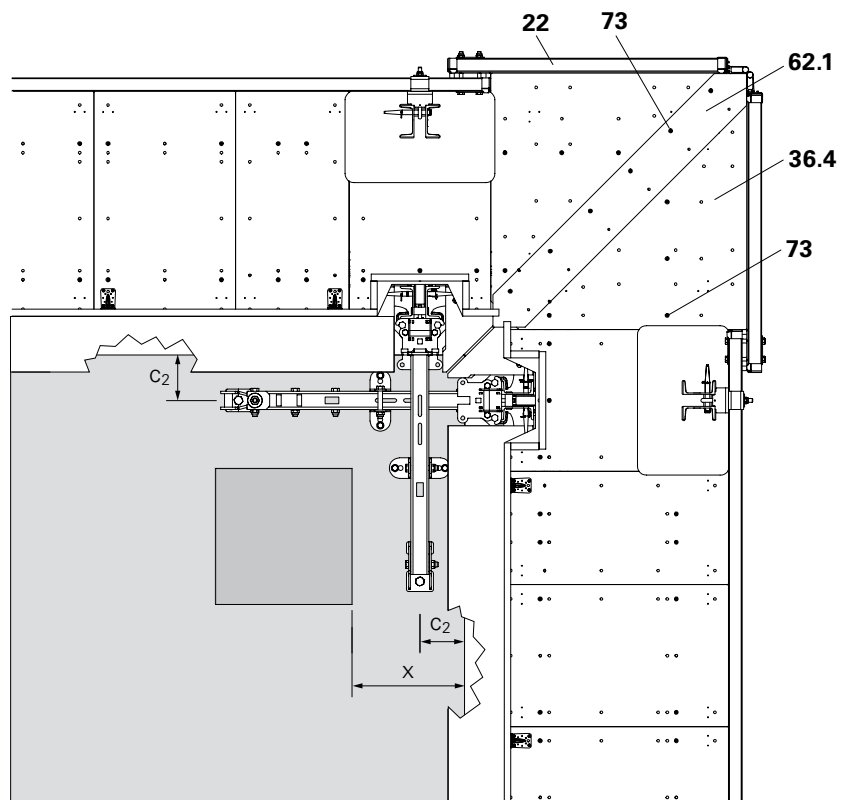

Fig. B3.03

Corner elements with building column

For small, rectangular building columns at the corner of the building, a overlapping arrangement of the corner elements might be required.

At the corner of the building: a cross-wise arrangement of the Slab Shoe-2 LPS (10) and Slab Shoe Corner-2 LPS (11).

On the front sides of the working platform, connect the Telescopic Screen (22) with the Screen Adapter Corner LPS (28) to the Telescopic Screen (22a) on the outside.

(Fig. B3.04)
Cover remaining gaps.



- This version is not covered by the standard assembly. Additional static proof for wind loads parallel to the edge of the building must be provided.
- If necessary, a horizontal support is to be dimensioned and arranged parallel to the edge of the slab.
- In this case, it is not possible to pass around the corner.

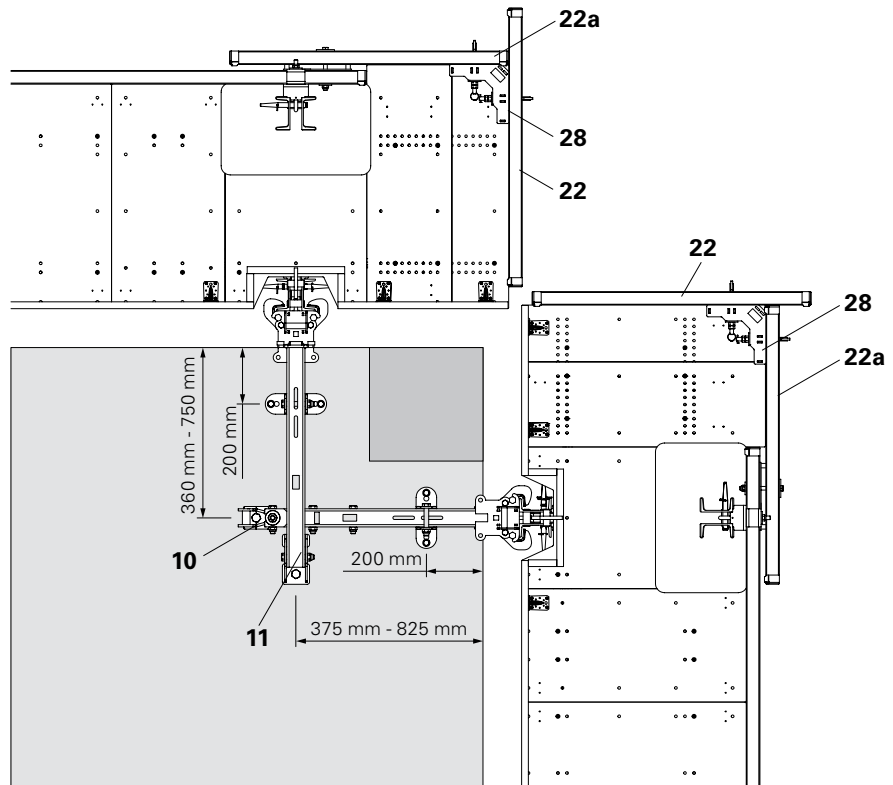

Fig. B3.04

Components

10	Slab Shoe-2 LPS
11	Slab Shoe Corner-2 LPS
22	Telescopic Screen DX LPS
28	Screen Adapter Corner LPS

For larger building columns at the building corners, a Rail Guidance Shoe LPS (12) can be used for the anchoring in the column. This can take place on one or both sides. As a result, the cantilevers of the corner elements are, thus, kept as small as possible.

Depending on the arrangement of the slab shoes, change the platform covers of the Platform LPS. (Fig. B3.05a)

For larger cantilevers, an additional third Platform Cover (34) can be installed, see Section B2 Planning of Units - "Platform Extension" on Page 44. (Fig. B3.05)



- This version is not covered by the standard assembly. Additional static proof for wind loads parallel to the edge of the building must be provided.
- In order to make self-climbing possible, the right height offset from the Rail Guidance Shoe to the upper slab edge must be observed. See Section "Mixed Suspension" on Page 36.

Components

- | | |
|-----------|------------------------|
| 10 | Slab Shoe-2 LPS |
| 12 | Rail Guidance Shoe LPS |
| 34 | Platform Beam LPS |

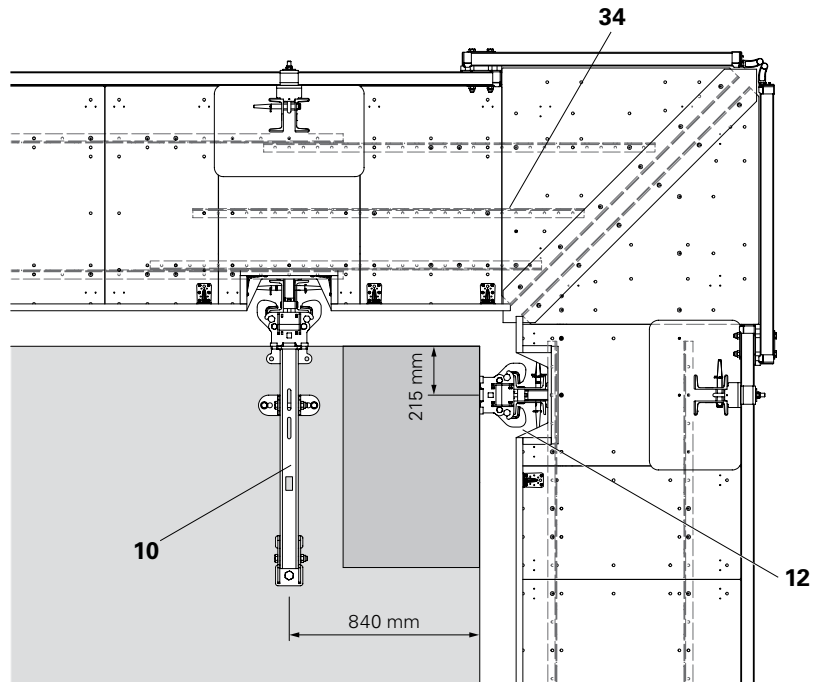
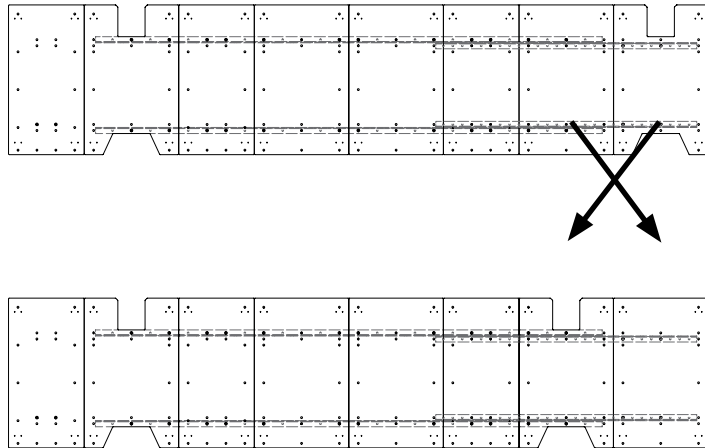

Fig. B3.05



Internal Corners

Version 1, stright climbing enclosure

At the internal corners, extend the enclosure with Telescopic Screens (22), Telescopic Scaffold Tube (44) and foldable covers (40).

The distance from the centre of the slab shoe to the building corner (here 1.60 m) can be planned between 1.20 m and 2.00 m.

Cut mitred foldable covers (40) for the inside corner, as well as up to the Telescopic Screen (22).

In order to fold up the foldable cover without the risk of any collision, the Cover Plate for the internal corner (47) must be fitted with a screwed on Hinge (85).

For the climbing procedure, first fold up the Cover Plate for the internal corner (47), then fold up the foldable cover (40). (Fig. B3.06)

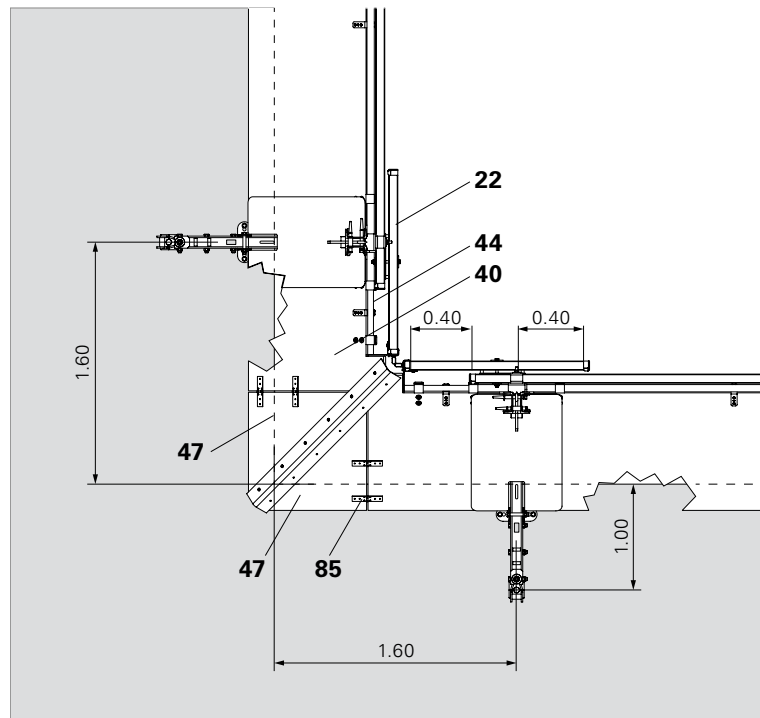

Fig. B3.06

Components

22	Telescopic Screen DX LPS
34	Platform Beam LPS
36.4	Platform Cover Corner LPS 105 x 105
40	Foldable Cover
44	Telescopic Scaffold Tube LPS
47	Cover Plate for Internal Corner
85	Hinge DIN 7957-200-ST

Version 2, climbing enclosure with working platform

Bottom enclosure

At the internal corners, extend the enclosure with Telescopic Screens (22), Telescopic Scaffold Tube (44) and foldable covers (40).

Cut mitred foldable covers (40) for the inside corner, as well as up to the Telescopic Screen (22).

In order to fold up the foldable cover without the risk of any collision, the Cover Plate for the internal corner (47) must be fitted with a screwed on Hinge (85).

For the climbing procedure, first fold up the Cover Plate for the internal corner (47), then fold up the foldable cover (40). (Fig. B3.07)

Working platform

Extend the internal corners of the working platforms with platform beams (34) and Platform Cover Corner (36.4).

With a distance of the shoes to the corner of 1.60 m and no projection of the slab shoes (10), no Telescopic Screens are required in the platform area. (Fig. B3.08)

Components

22	Telescopic Screen DX LPS
34	Platform Beam LPS
36.4	Platform Cover Corner LPS 105 x 105
40	Foldable Cover
44	Telescopic Scaffold Tube LPS
47	Cover Plate for Internal Corner
85	Hinge DIN 7957-200-ST

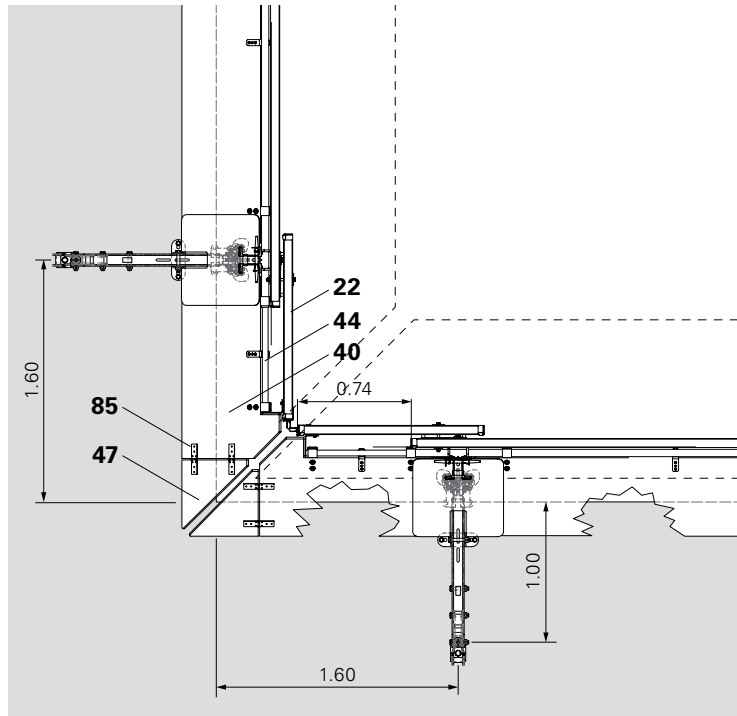

Fig. B3.07

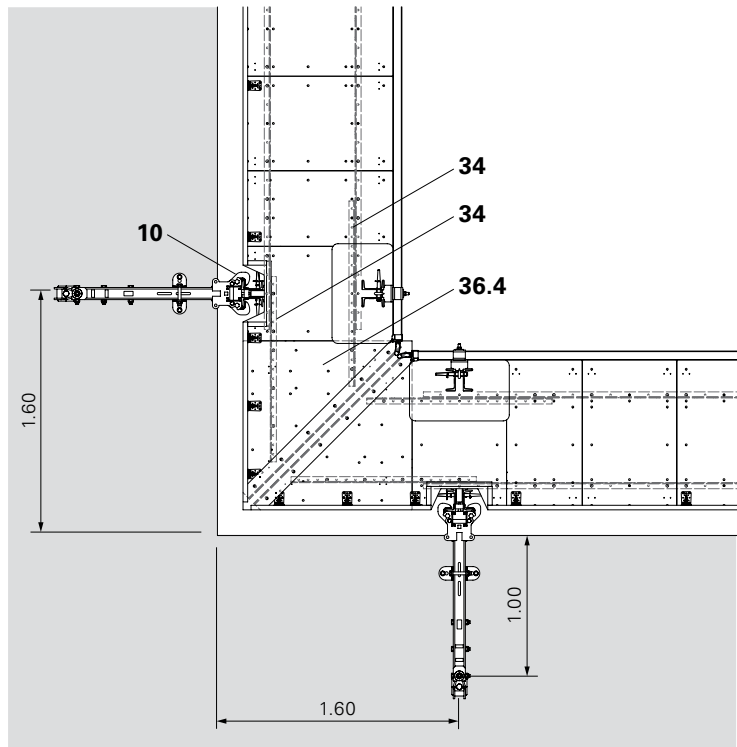

Fig. B3.08

Non-right-angled building corners

For non-right-angled building corners, combine the Slab Shoe (10) with the Slab Shoe Corner (11).

This combination results in an application range for α of min. 65° and max. 135° .

Outside this range, specific measures are required.

Obtuse-angled corners

In the case of obtuse angles $> 90^\circ$, extend the platform decking with mitred untreated plywood (79) and Platform Beams (34).

Supplement the mesh panel enclosure with Telescopic Screens (22).

The slab shoe arrangement is primarily determined by the ability to screw the anchor bolts into the guiding bracket (10.6 of the Slab Shoe).

(Fig. B3.09)

Components

10	Slab Shoe-2 LPS
11	Slab Shoe Corner-2 LPS
22	Telescopic Screen DX LPS
34	Platform Beam LPS
79	Untreated Plywood 20, 21 mm

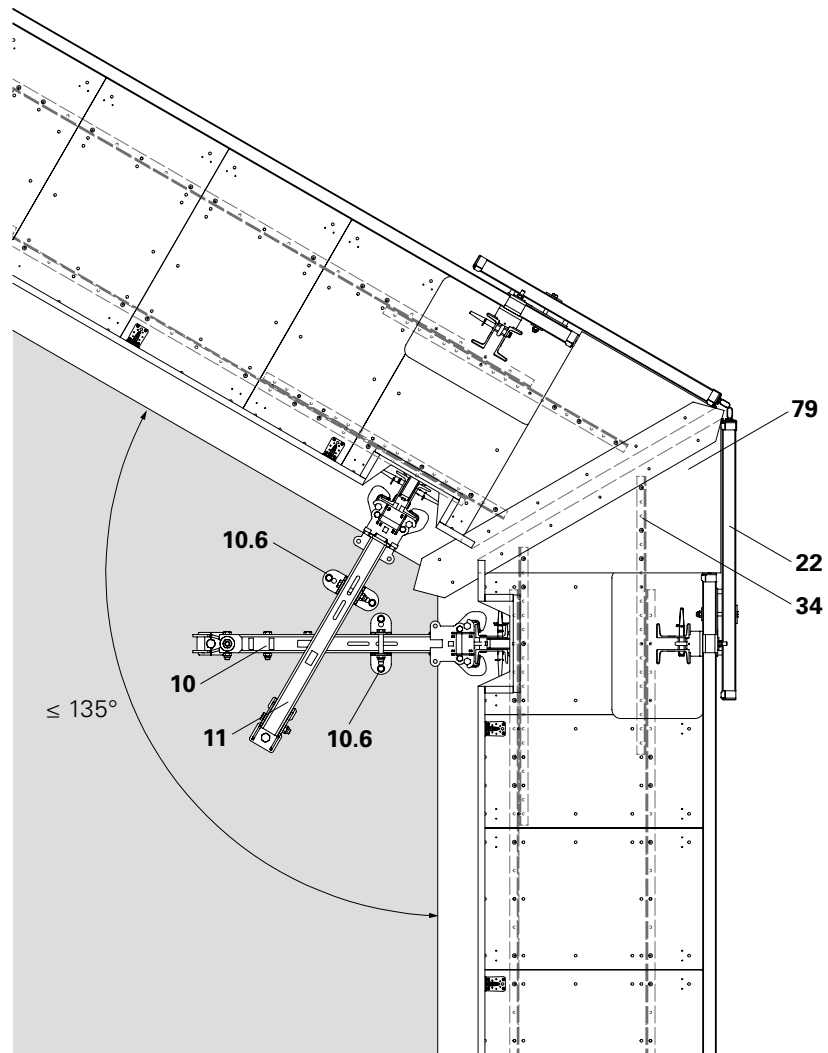

Fig. B3.09

Acute-angled corners

For acute angles $< 90^\circ$, PERI recommends extending the platforms up to just before the angle bisector with the Platform Cover (36).

On the front sides of the working platform, connect the Telescopic Screen (22) with the Screen Adapter Corner LPS (28) to the Telescopic Screen (22a) on the outside.

Cover remaining gaps.

It is not possible to pass around the corner.

(Fig. B3.10)



Going below a lateral edge distance c_2 of 200 mm for the anchoring is not advisable without additional static proof. If necessary, measure and arrange edging reinforcement in the slab.

Components

- 22** Telescopic Screen DX LPS
- 28** Screen Adapter Corner LPS
- 34** Platform Beam LPS
- 35.5** Platform Cover LPS 37.5 x 107.5

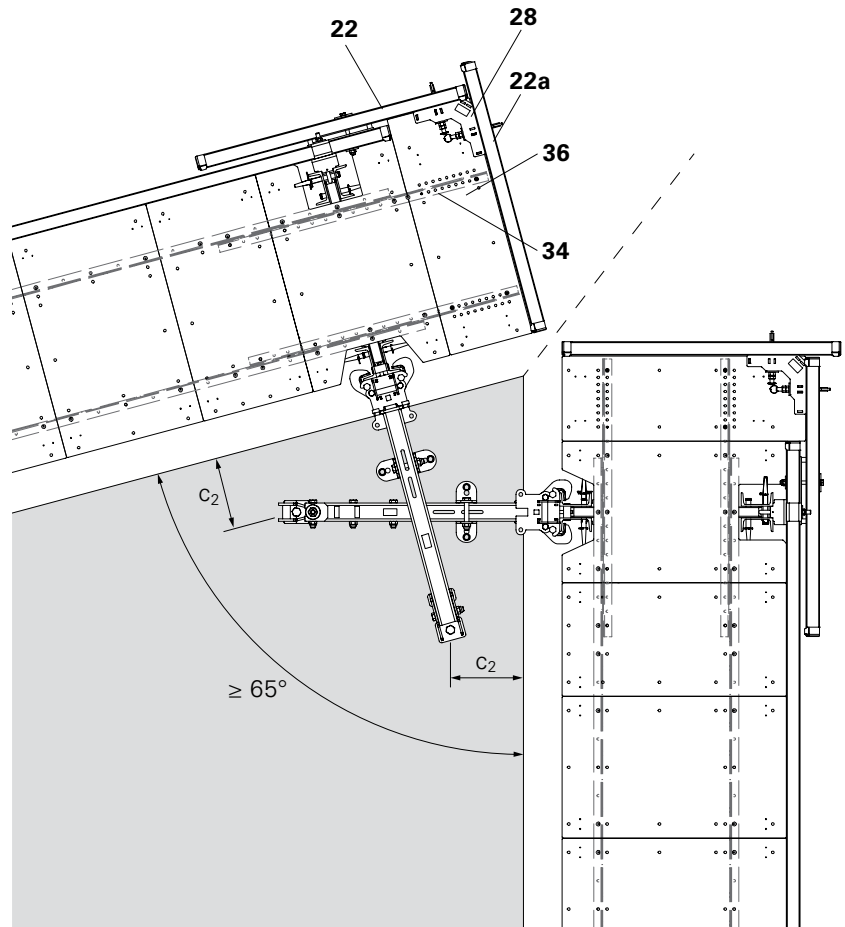

Fig. B3.10

Units on Circular Structures

On circular structures, the platform extensions are jointed with mitre cut plywood (79) or special sheet metal.

Slab Shoes (10), Climbing Rails and Platform Cantilever Beams (32) are arranged parallel to each other for each climbing unit.

The smallest possible building radius is approx. 4 m. During the planning process, take into consideration a gap S_1 of ≥ 30 mm between the platform decking (33) and building edge. Plan the anchoring of the slab shoes to be at least 20 cm apart. Otherwise static proof is to be provided. The foldable covers must be wide enough so that they cover all areas of the building edge. Cover remaining gaps.

The position of the anchoring is to be determined on the drawing and must be clearly dimensioned. (Fig. B4.01)



The lateral adjustability of the Slab Shoe (10) must be guaranteed. Therefore, during the planning phase, ensure that the gap dx between the building edge and the stop plate of the Slab Shoe is min. 10 mm along the whole width of the shoe. (Fig. B4.01a + B4.01b)

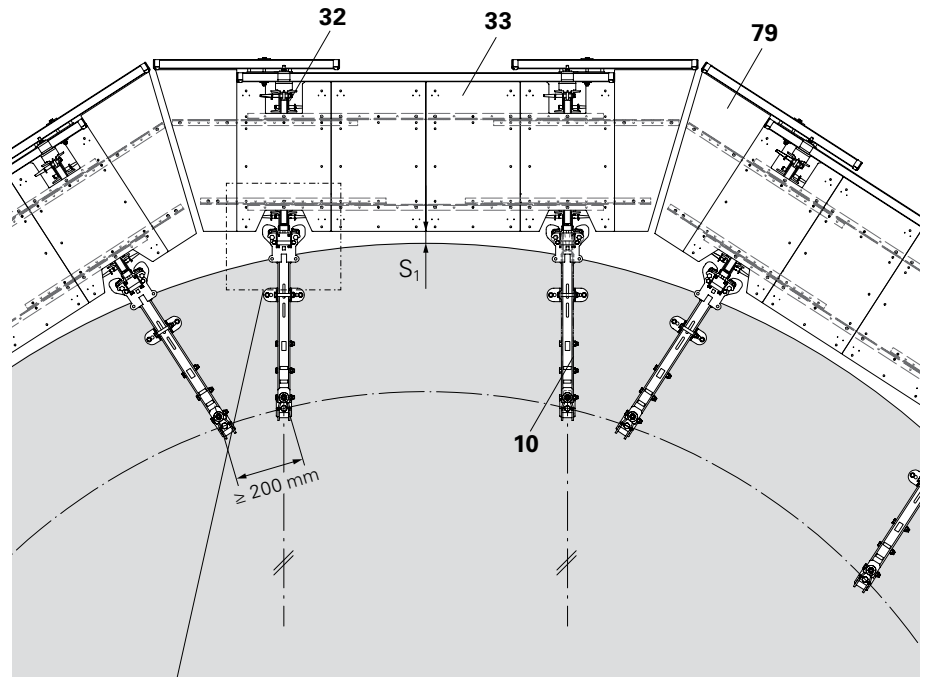

Fig. B4.01

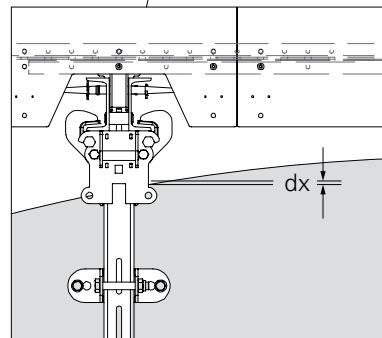

Fig. B4.01a

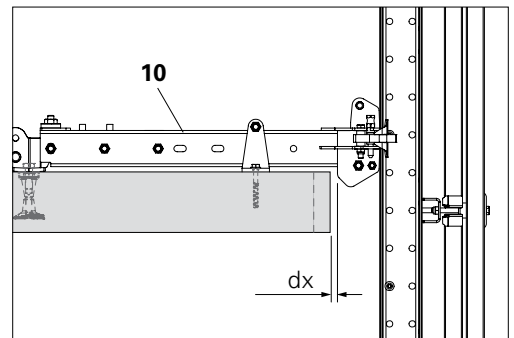

Fig. B4.01b

Components

- | | |
|-----------|-----------------------------|
| 10 | Slab Shoe-2 LPS |
| 32 | Platform Cantilever Beam |
| 33 | Platform LPS |
| 79 | Untreated Plywood 20, 21 mm |

Anchoring to Columns

Suspension with the Rail Guidance Shoe LPS

Slab Shoes and Rail Guidance Shoes must be in the same vertical system grid. For this, the suspension of the Rail Guidance Shoe (12) is height-adjusted by Δh in 125 mm increments to the top edge of the slab. (Fig. B4.02a)

If the climbing enclosure is to be moved with the self-climbing device, an offset Δh of 500 mm is required. This offset is ensured if the dimension Δh_1 is 375 mm.

The following is valid for other offset dimensions:
 $\Delta h_1 = 375 / 875 / 1375 / 1875$.

Adapt foldable covers (40) to suit the building columns. (Fig. B4.02b)
 Close remaining gaps with Cover Mat LPS 41 x 66 (61.2) and Cover Strip (62). (Fig. B4.02c)



The negative offset of the Rail Guidance Shoe is to be added to the storey height itself and taken into account in the design.

Components

- | | |
|-------------|--------------------------|
| 2 | Climbing Rail-2 LPS |
| 12 | Rail Guidance Shoe-2 LPS |
| 40 | Foldable Cover |
| 61.2 | Cover Mat LPS 41 x 66 |
| 62 | Cover Strip LPS 20 x 108 |

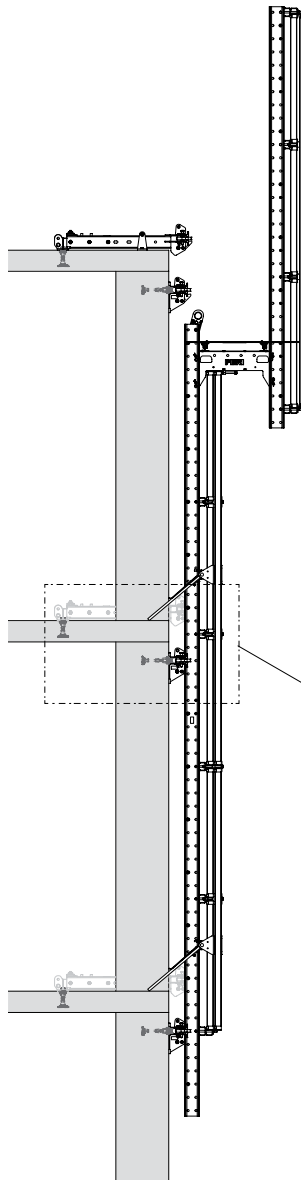

Fig. B4.02

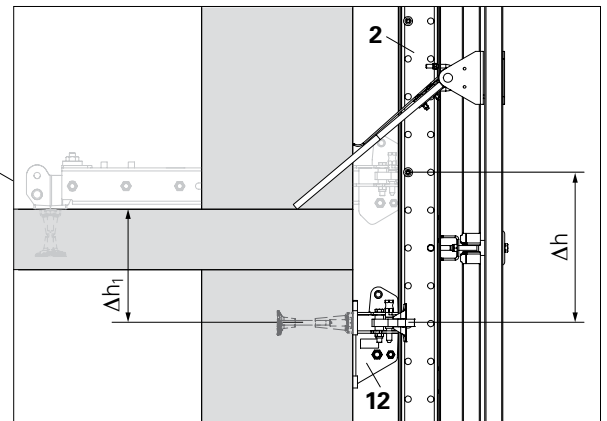

Fig. B4.02a

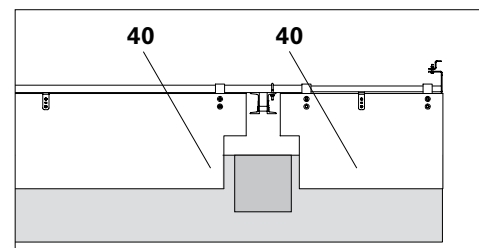

Fig. B4.02b

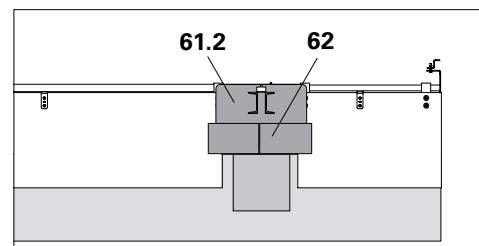

Fig. B4.02c

Variants

In addition to the standard configuration shown in these Instructions for Assembly and Use, a wide range of assembly versions is possible. Accurate planning can lead to deviating solutions, possibly using components that must be produced according to customer-specific requirements.



The following assembly versions are not covered by the standard configuration. They are examples only and not to be understood as assembly instructions in any way. All assembly versions require separate static proof, an additional project-related risk assessment and assembly instructions provided by the contractor (user).

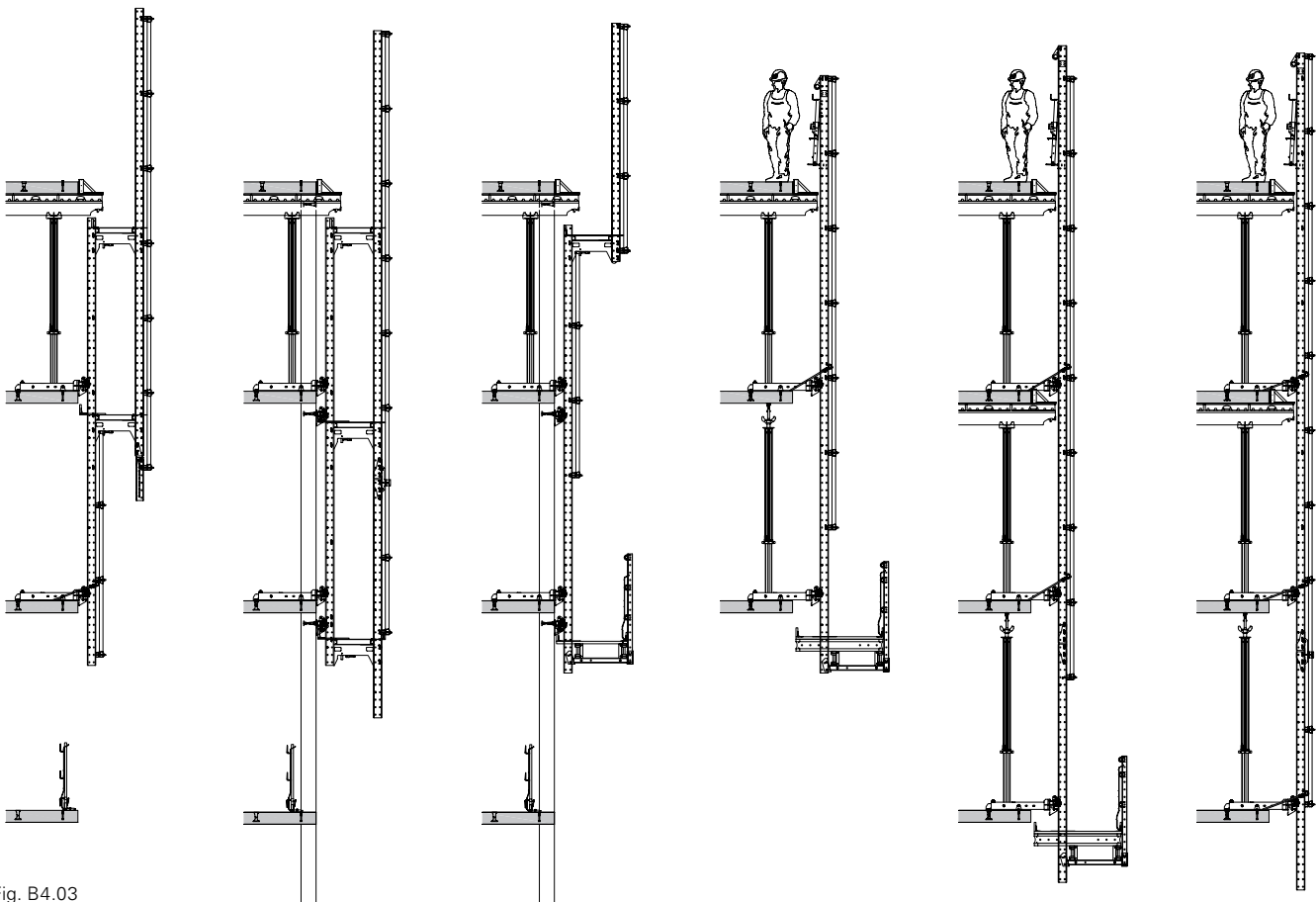

Fig. B4.03

LPS solution with additional working platforms for circumferential access or anchored in the walls.

LPS solution with additional finishing platforms anchored in the walls or as finishing platform for post-tensioning.

Straight LPS solution extended in height with additional finishing platform for post-tensioning or just increased protection height.

Additional Finishing Platforms

Finishing platforms can be provided in the area of the bottom Slab Shoe. For this, a finishing platform is bolted to the Climbing Rail. (Fig. B4.04)



The finishing platform is not covered by the standard application. Separate static proof is required! See "PERI Product Information PI 314 D".

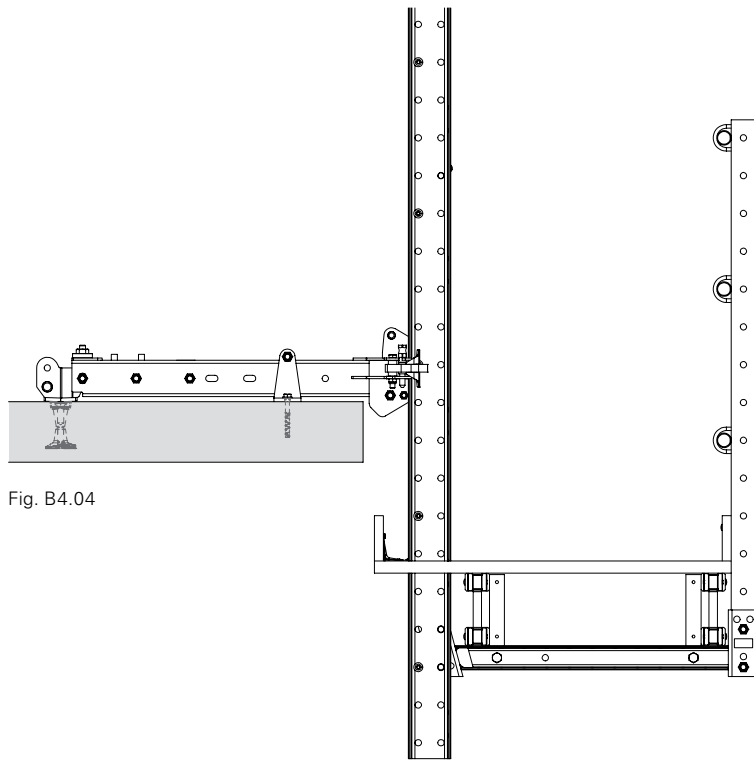

Fig. B4.04

General

For pre-assembly, there must be a sufficiently large and level assembly area available, as well as sufficient space for intermediate storage.

Furthermore, a crane or other lifting equipment is required.

Any intermediate status is to be correctly secured by means of temporary supports to prevent any tipping over.

Assembly is carried out on aligned timbers.

Preparation of the Climbing Rails

Position Climbing Rails-2 LPS on timbers. Observe centre of gravity position with enclosure post.

Turn Climbing Rail so that the spacers are on the underside.

Assembly of the spacers

In some cases, the additional installation of a Spacer LPS (2.1) may be required as a Climbing Bolt in the Climbing Rail, see "Additional Spacers" on Page 31.

1. Position Spacer Tube M20 Ø 30x52 (2.3) of the Spacer M20 in the Climbing Rail-2 LPS by means of a hammer.
2. Turn Climbing Bolts LPS M20 (2.4) on both sides through the holes Ø 21 on the Climbing Rail into the Spacer Tube M20.
3. Tighten all Climbing Bolts with Allen Key SW 10. Tightening torque min. 60 Nm.

(Fig. C1.01 + C1.02)

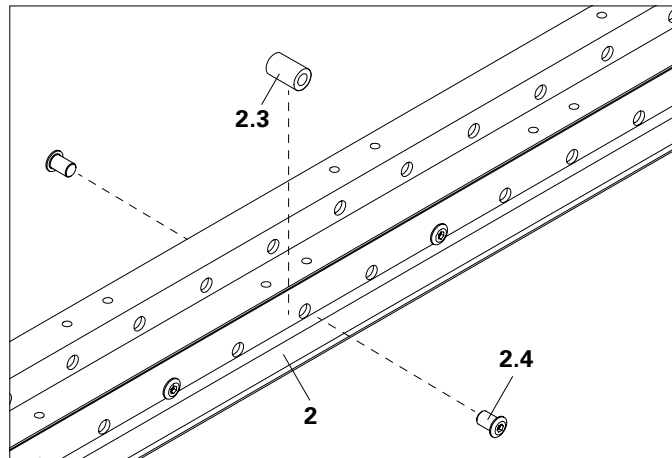

Fig. C1.01

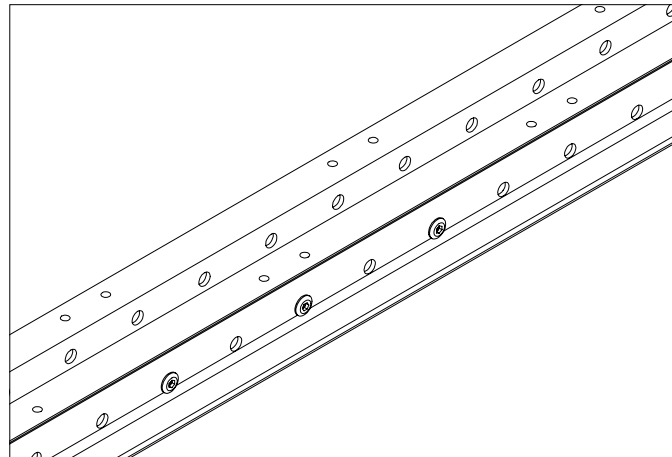

Fig. C1.02



Has the Climbing Bolt been tightened?



Only use the specified original PERI Climbing Bolt!

Components

- | | |
|------------|-----------------------|
| 2 | Climbing Rail-2 LPS |
| 2.3 | Spacer Tube LPS |
| 2.4 | Climbing Bolt LPS M20 |

Assembly of the Attachment Points

Fix the Crane Eye BR-2 2.5 t (7) to the Climbing Rail-2 LPS with fitting pins (81).

1. Position Crane Eye BR 2.5 t (7) in the Climbing Rail.
2. Insert fitting pins (81) through the holes of the Climbing Rail and then through the Crane Eye.
3. Secure fitting pins with cotter pins 4/1 (86).

(Fig. C1.03 + C1.04)

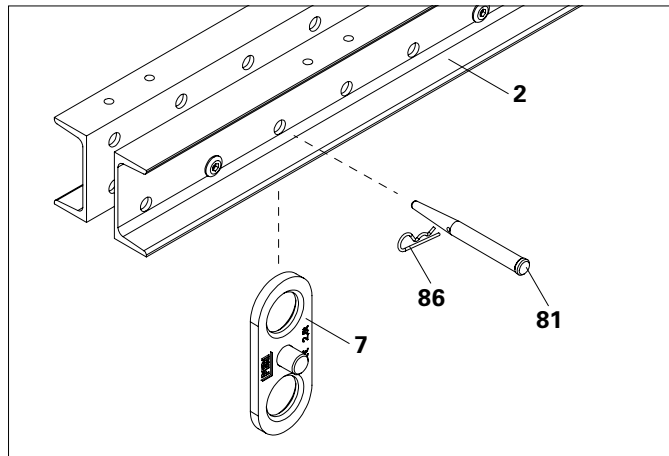

Fig. C1.03



Permissible load per Crane Eye BR-2 2.5 t: max. 25 kN.

For moving heavy climbing units, use Lifting Beam10 t. Use a Spacer as an attachment point.

Follow Instructions for Use at all times!

Components

2	Climbing Rail-2 LPS
7	Crane Eye BR-2 2.5 t
81	Fitting Pin Ø 21x120
86	Cotter Pin 4/1

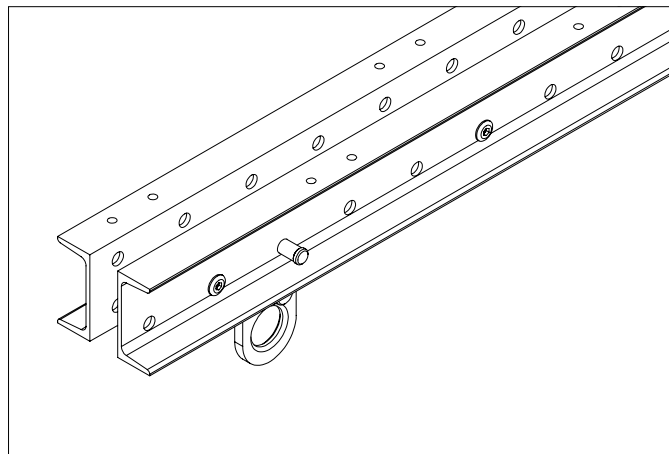

Fig. C1.04

Assembly of Rail Connector SRU/LPS

Enclosure Post Version 1:

The Climbing Rail-2 LPS (2) is extended by means of a Rail Connector SRU/LPS (6) with the Steel Waler Universal SRU (3).

1. Insert Rail Connector SRU/LPS (6) into the Climbing Rail LPS (2).
2. Insert 2x Fitting Pins $\varnothing 21 \times 120$ (81) and Cotter Pins 4/1 (86) through holes $\varnothing 21$ to secure Rail Connector.
3. Position the Steel Waler Universal (3) on the Rail Connector SRU/LPS, and secure by means of a further 2x Fitting Pins $\varnothing 21$ and 4/1 Cotter Pins inserted through the $\varnothing 21$ holes.

(Fig. C1.05 + C1.06)

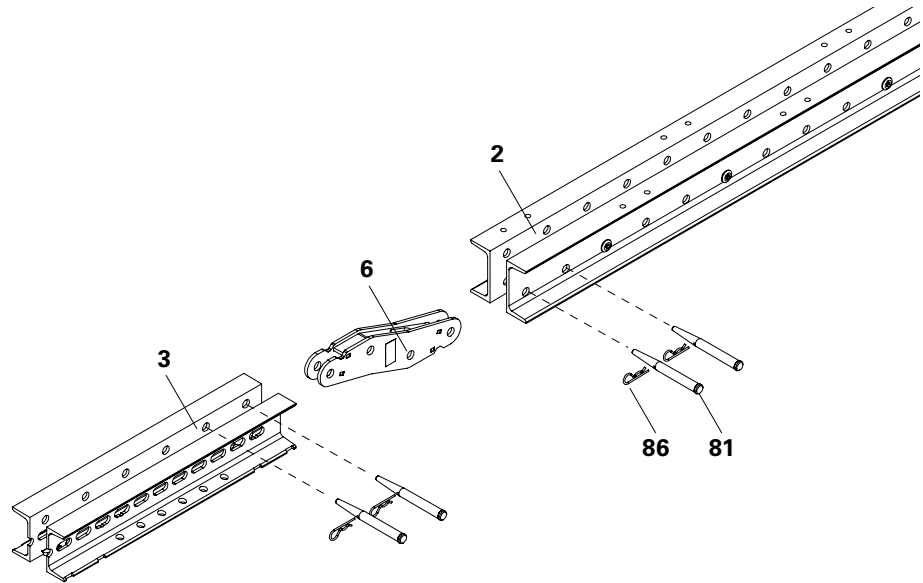

Fig. C1.05



- When mounting Steel Walers Universal SRU that are longer than those specified in the standard configuration, the static load-bearing capacity of the Rail Connector for wind loads and load case erection must be verified.
- The Slab Anchor Template LPS cannot be mounted on the Steel Waler Universal.



Note

The SRU profile (3) does not fit in the Rail Guidance Shoe LPS.

The Fitting Pins (81) in the Climbing Rail collide with the guiding skids of the Rail Guidance Shoe.

This can cause damage to the climbing enclosure and reduce the load-bearing capacity of the anchoring.

⇒ Always install and close the Rail Guidance Shoe below the Rail Connector.

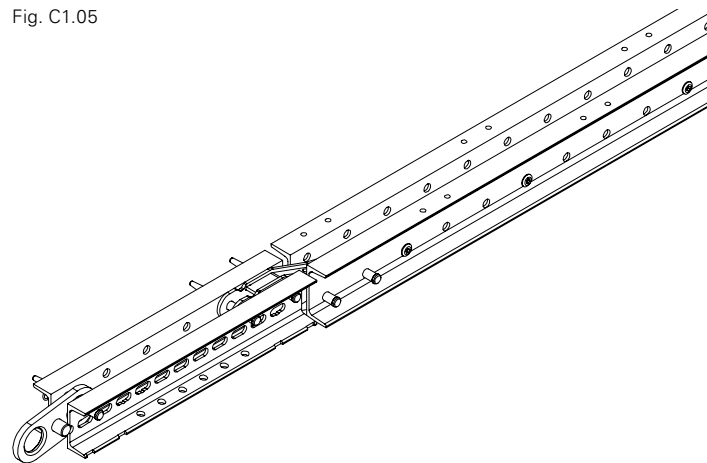

Fig. C1.06

Components

2	Climbing Rail-2 LPS
2.1	Spacer LPS 52
3	Steel Waler Universal SRU
6	Rail Connector SRU/LPS
81	Fitting Pin $\varnothing 21 \times 120$
86	Cotter Pin 4/1

Assembly of Rail Connector LPS

The Climbing Rail LPS (2) and (2a) are extended by means of the Rail Connector LPS (5).

1. Remove or re-position Spacers (2.1) in the Climbing Rail that are in the way.
2. Insert Rail Connector LPS (5) into the Climbing Rail LPS (2). The mounting direction of the Rail Connector is carried out as shown.
3. Secure Rail Connector by inserting 2x Fitting Pins \varnothing 21x120 (81) and Cotter Pins 4/1 (86) through holes \varnothing 21.
4. Position additional Climbing Rail (2a) on Rail Connector SRU/LPS, and secure by inserting 2x Fitting Pins \varnothing 21x120 and Cotter Pins 4/1 through holes \varnothing 21.

(Fig. C1.07 + C1.08)



- When mounting Climbing Rails that are longer than those specified in the standard configuration, the static load-bearing capacity of the Rail Connector for wind loads and load case erection must be verified.
- Screen Adapters cannot be mounted in the area of the Rail Connector.



Note

When Fitting Pins (81) are mounted on the inside of the Climbing Rail, the Fitting Pins collide with the guiding skids of the Rail Guidance Shoe.

This can cause damage to the climbing enclosure and reduce the load-bearing capacity of the anchoring.

⇒ Always install the Climbing Rail Connector and Fitting Pins on the outside.

Components

2	Climbing Rail-2 LPS
2.1	Spacer LPS 52
5	Rail Connector LPS
81	Fitting Pin \varnothing 21x120
86	Cotter Pin 4/1

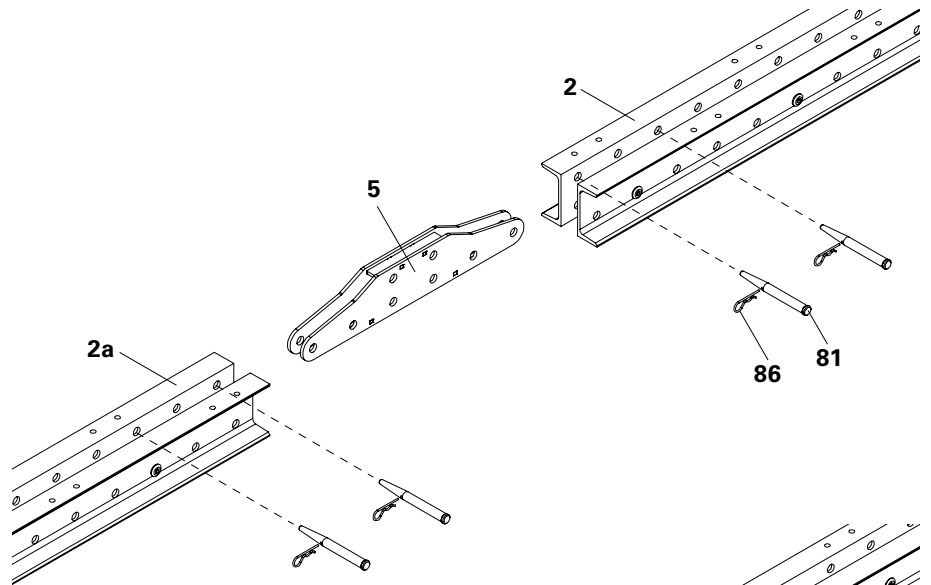

Fig. C1.07

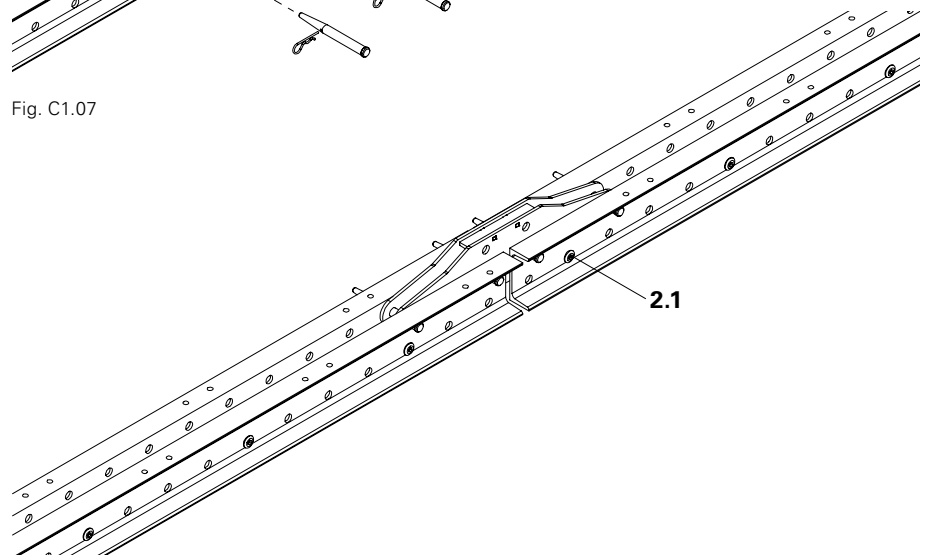

Fig. C1.08

Extension of the protection panel in a vertical position.

During pre-assembly, always ensure that the Rail Connector on the first Climbing Rail (2) is in a horizontal position.

Preparation:

1. Mount Screen Support LPS M20 (5.1) to Rail Connector LPS (5) using the attached Bolts M20x120 (5.2) and Nuts M20.
2. Insert Rail Connector LPS (5) into the Climbing Rail LPS (1) and secure by inserting 3x Fitting Pins \varnothing 21 (81) and Cotter Pins 4/1 (86) through holes \varnothing 21.
3. Mount Screen Element (21). There is no top Screen Adapter Single LPS 60. Instead, insert the Screen Element into the Screen Support.
4. Position climbing enclosure on the building. (Fig. C1.09 + C1.10)

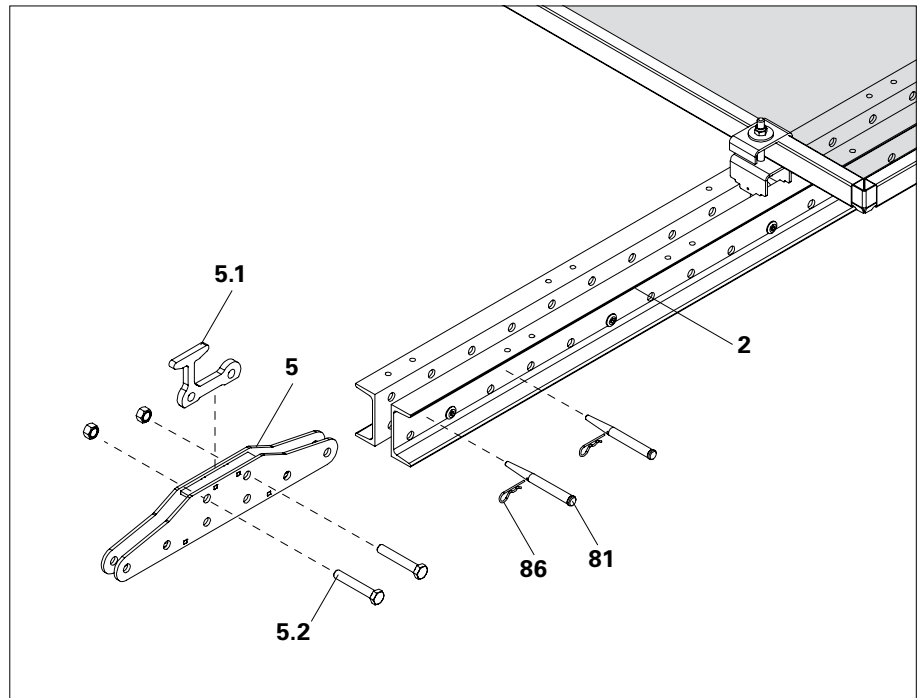

Fig. C1.09

Components

2	Climbing Rail-2 LPS
5	Rail Connector LPS
5.1	Screen Support LPS M20
5.2	Bolt M20x120
81	Fitting Pin \varnothing 21x120
86	Cotter Pin 4/1

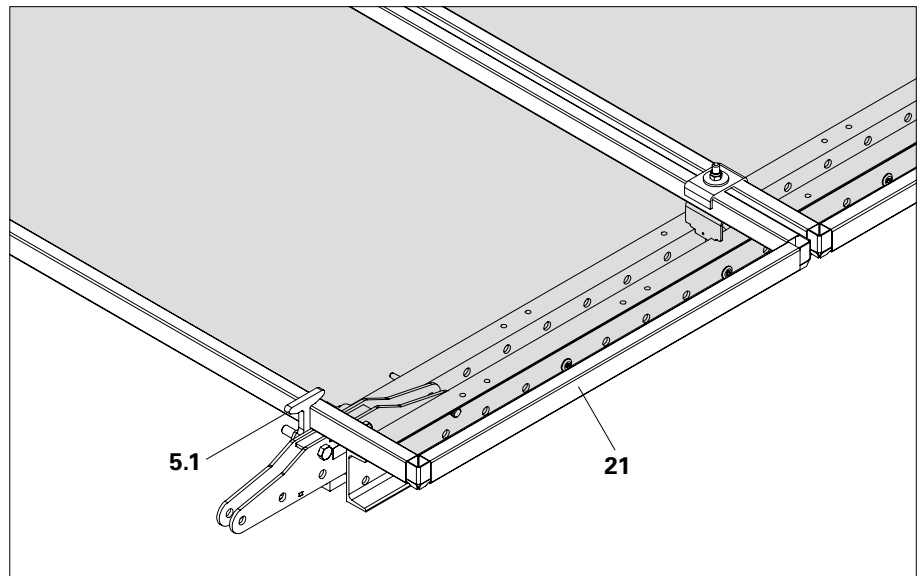

Fig. C1.10

Extension:

1. Horizontally pre-assemble the top pair of Climbing Rails. Thereby, provisionally secure the bottom Screen Element in the lower area to the Climbing Rails (2a) by means of timber (76) and e.g. TORX 6x80 and Washer ISO 7094-08. The Screen Element must be positioned parallel to the Climbing Rails.
2. With the crane, insert the Climbing Rail LPS (2a) into the Climbing Rail Connector (5), and the Screen Element (21) in the Screen Support LPS (5.1).
3. Climbing Rail is secured by inserting an additional 2x Fitting Pins \varnothing 21 (81) and Cotter Pins 4/1 through holes \varnothing 21.

(Fig. C1.11)



There is an old type of Climbing Rail Connector LPS, which has to be modified (drill 2 additional holes) for fixing of the Screen Support LPS M20. In this case, please contact PERI for advice.

Components

2	Climbing Rail-2 LPS
5	Rail Connector LPS
5.1	Screen Support LPS M20
21	Screen Element DX LPS
25	Screen Adapter Double LPS 60
76	Timber
81	Fitting Pin \varnothing 21x120
86	Cotter Pin 4/1

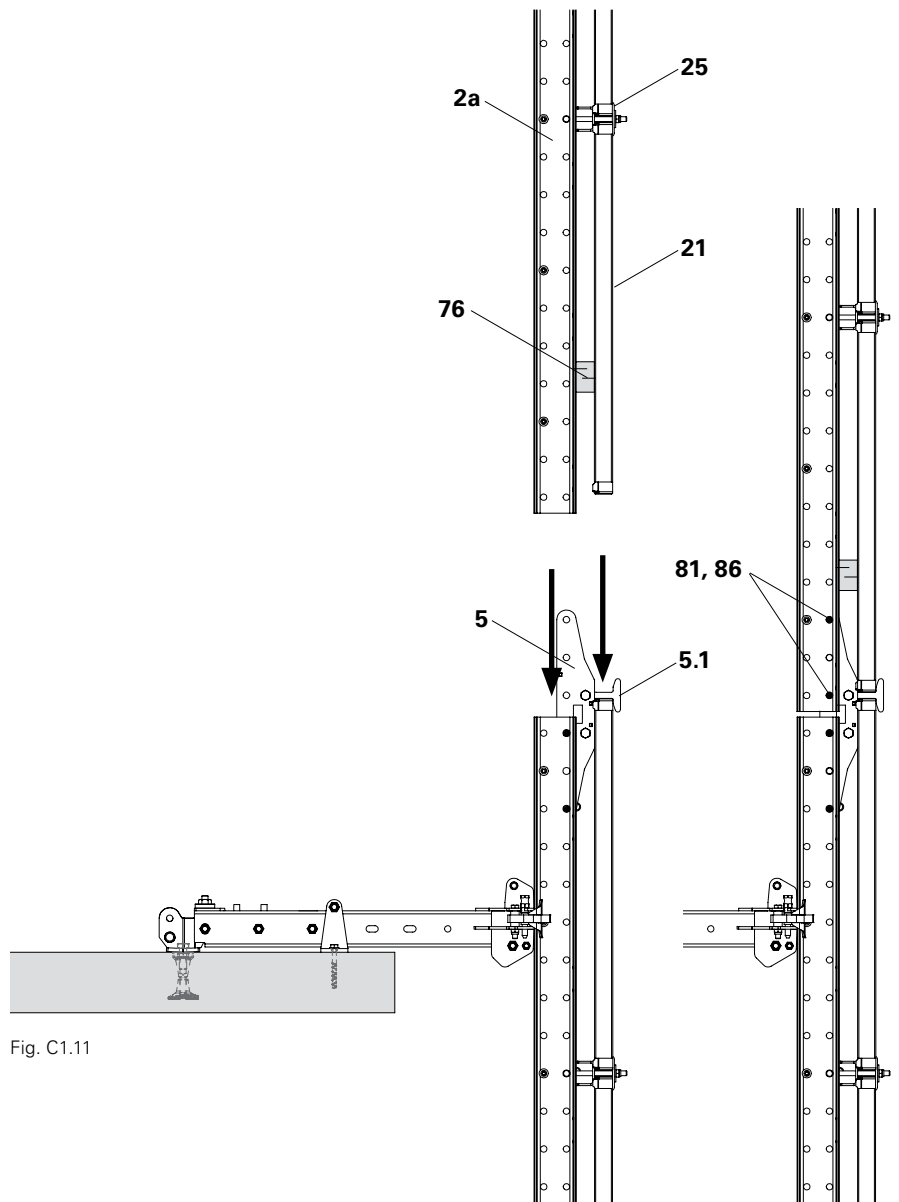

Fig. C1.11

Platform LPS

Pre-assembly Platform LPS with Platform Cantilever Beam

1. Insert Fitting Pins (81) in Platform Cantilever Beam (32) on one side and place on Climbing Rail (2). Fix other Fitting Pins (81a) and Cotter Pins (86) in the fifth holes of the Climbing Rail. (Fig. C1.12)
2. Align the Climbing Rails to the axial dimension of the platform.
3. Fix Platform LPS (33) to the Platform Cantilever Beam (32) by inserting Bolts ISO 7380 M10x25 (73) through the Platform Cantilever Beam and securing with Nuts M10 (73.1). Position Nut (73.1) through the working opening in the Platform Cantilever Beam. (Fig. C1.13)
4. Turn the platform upwards over the Fitting Pins (81a) and insert Fitting Pin (81) and Cotter Pin in the Climbing Rail. (Fig. C1.14)

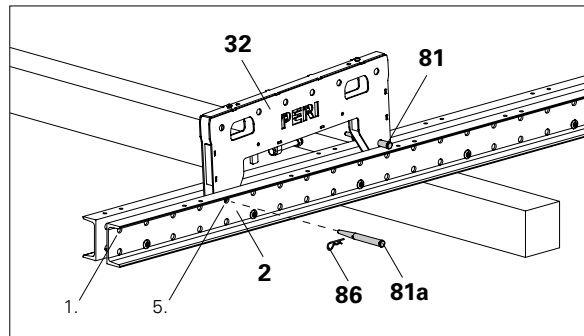

Fig. C1.12

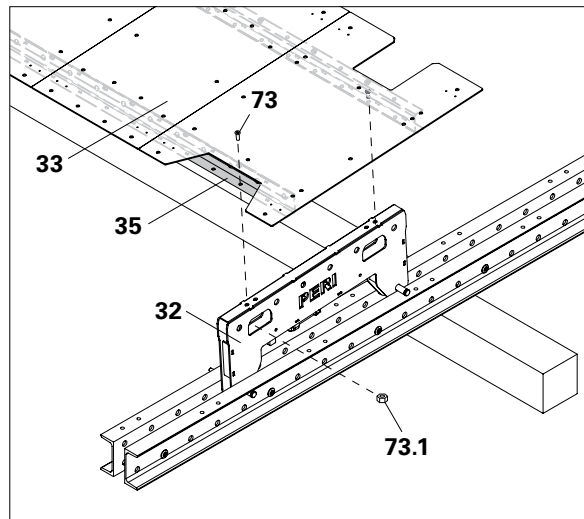

Fig. C1.13

Assembly of the platform extension

Mount the platform extension only after road transport has taken place, see Section C2 "Installation on Site" on Page 87.

Assembly of the toe boards

Mount the Toe Boards only after road transport has taken place, see Section C2 "Installation on Site" on Page 88.

Components

2	Climbing Rail-2 LPS
5	Rail Connector LPS
32	Platform Cantilever Beam LPS
33	Platform LPS
35	Platform Beam LPS
73	Bolt ISO 7380 M10x25
73.1	Nut M10
81	Fitting Pin Ø 21 x 120
86	Cotter Pin 4/1

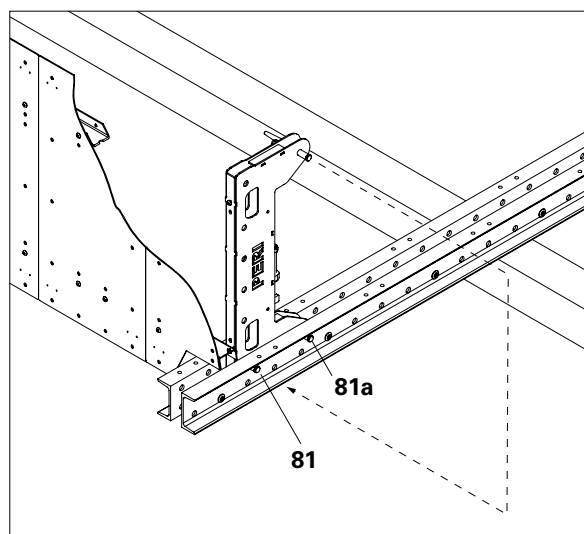

Fig. C1.14

Assembly of the Enclosure Post

1. Turn Climbing Rail 398 (2) so that the Spacers (2.1) are on the upper side.
 2. Position the Climbing Rail on the Platform Cantilever Beam (32) with the crane.
 3. Secure the Climbing Rail with 2x Fitting Pins (81) and Cotter Pins (86).
- (Fig. C1.15)

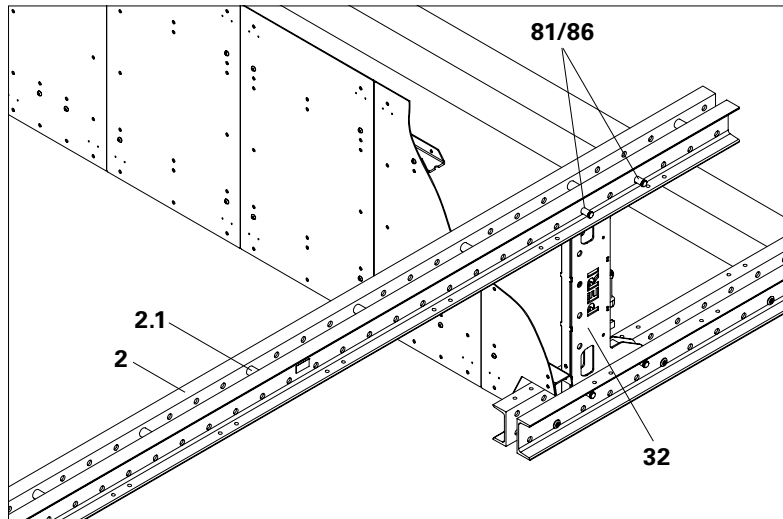

Fig. C1.15

Assembly of the Cover Flaps

1. Fix scaffold tube (43) to the Climbing Rails (2) using Clamp A64 M12 (74) and Nuts M12 (74.1). The position is specified in the planning documents. Lateral projection is 226 mm.
 2. As transport locking device, screw one tie rod (97) into both climbing rails with cam nuts. Tie rod has a max. 20 cm projection on the outside.
- (Fig. C1.16 - C1.16a)

Alternatively, mount scaffold tube with Scaffold Tube Connector (46).

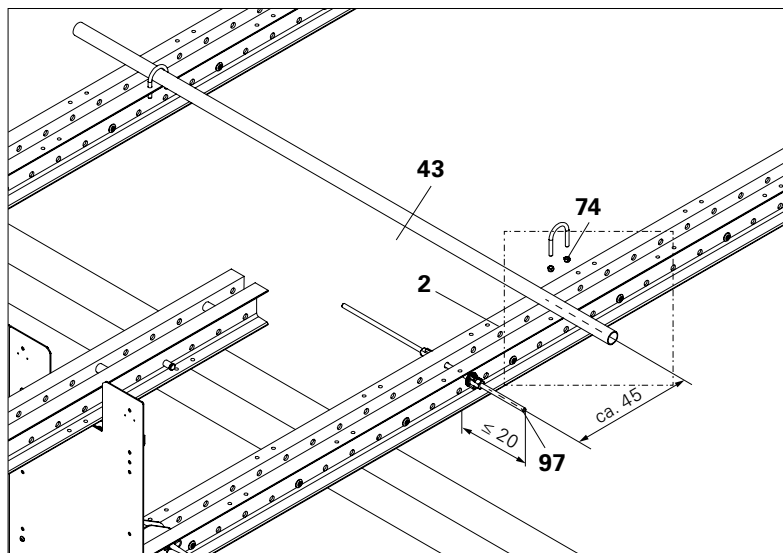

Fig. C1.16

Components

- | | |
|-------------|--------------------------------------|
| 2 | Climbing Rail-2 LPS |
| 2.1 | Spacer LPS 52 |
| 32 | Platform Cantilever Beam LPS |
| 43 | Scaffold Tube Ø 48/M10 LPS |
| 46 | Scaffold Tube Connector Ø 48-M10 LPS |
| 74 | Clamp A64 DIN 3570, M12 |
| 74.1 | Nut ISO 4032, M12-8 |
| 81 | Fitting Pin Ø 21x120 |
| 86 | Cotter Pin 4/1 |
| 97 | Tie Rod |

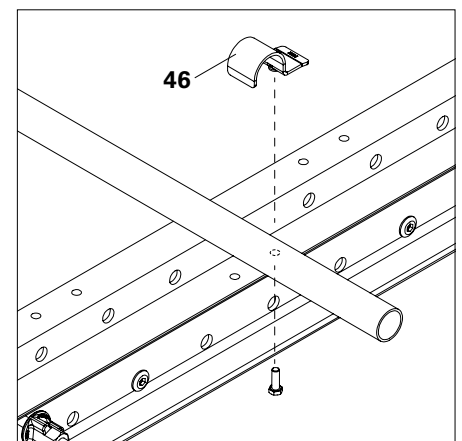
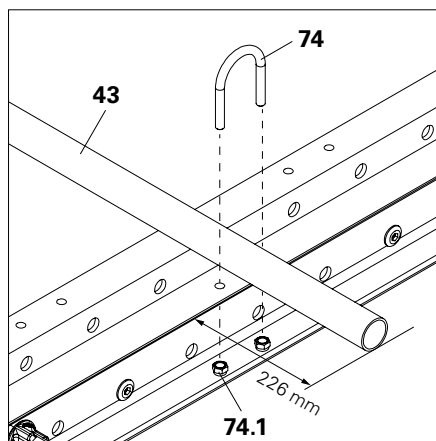

Fig. C1.16a

3. Cut untreated plywood to size and pre-drill with \varnothing 11 mm.
4. Mount Flap Hinges (41) with the supplied Bolts M10x50-8.8 (41.1) and Washers. Permissible arrangement: see Fig. B2.11 and Table B2.04 on Page 47.
5. Suspend the Foldable Cover (40) on the scaffold tube (43) and place on tie rod (97).
6. For each Foldable Cover, mount one Flap Safety Plate (42) approximately in the centre using 2 SPAX Screws TX 30 8x20. Foldable Cover is now secured. (Fig. C1.17)

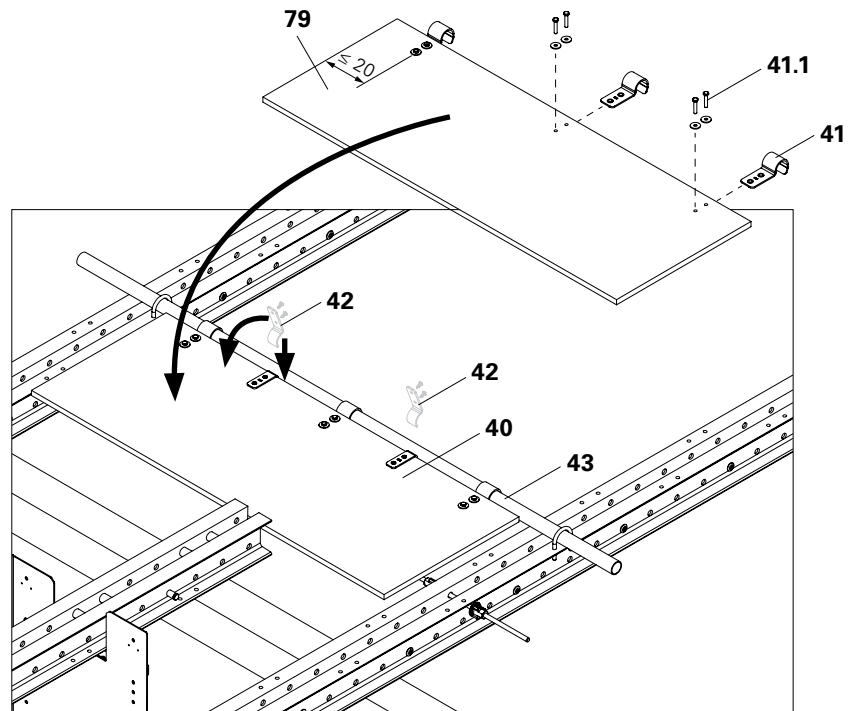

Fig. C1.17

Components

2	Climbing Rail-2 LPS
40	Foldable Cover
41	Flap Hinge LPS \varnothing 48/M10
41.1	Bolt M10x50-8.8
42	Flap Safety Plate LPS \varnothing 48
43	Scaffold Tube \varnothing 48.3 x 3.2
79	Untreated Plywood 20, 21 mm

Assembly of the Finishing Platform

1. Assemble Platform Covers, Kickers and Support Angles to create the finishing platform, see Section "Covering with Finishing Platforms" on Page 49.
2. Attach finishing platform to the Telescope Beam (50) that is still turnable using Bolts ISO 4017 M16x40 (72) and Nuts (72.1).
3. Insert Bolt \varnothing 16x36 (57) with Cotter Pin (86) into the 45° hole of the Support Angle, thereby preparing the finishing platform for transport. (Fig. C1.18a + C1.18b)
4. Position remaining bolts with cotter pins in the Support Angle.
5. Insert the Telescope Beam (50) with the suspensions (50.1) into the Climbing Rails (2). The clamping screws (50.2) of the telescopic tubes point upwards and inwards.
6. Secure suspensions with 2x Fitting Pins \varnothing 21x120 (81) and Cotter Pins (86) respectively.
7. Completely insert telescopic tubes (50.3) and secure them with clamping screws. (Fig. C1.18)

The finishing platforms in the telescoped area are first mounted on the construction site.

Components

2	Climbing Rail LPS
50	Telescope Beam Finishing Platform LPS
50.1	Suspension
50.2	Clamping Screw
50.3	Telescopic Tube
57	Bolt \varnothing 16x36
72	Bolt ISO 7014 M16x40-8.8
72.1	Nut ISO 7040 M16-8
81	Fitting Pin \varnothing 21x120
86	Cotter Pin 4/1

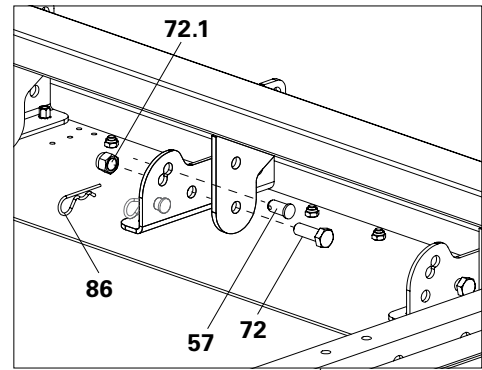

Fig. C1.18a

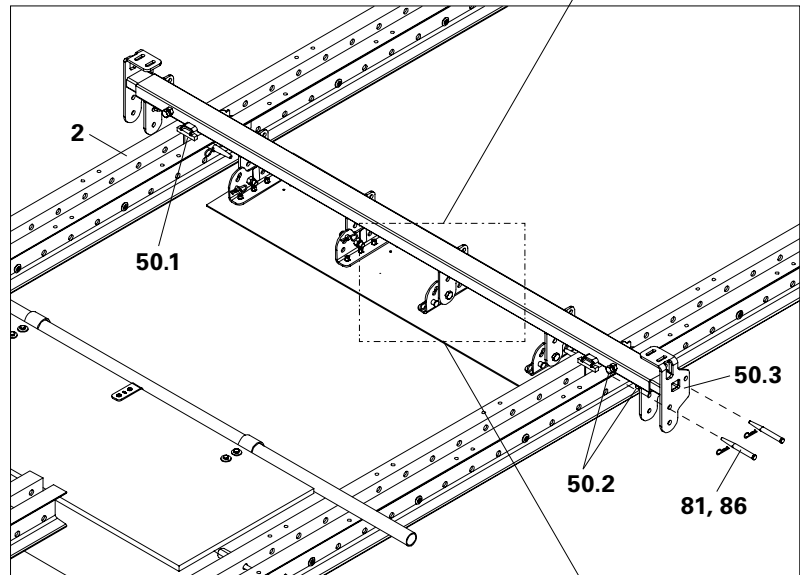

Fig. C1.18

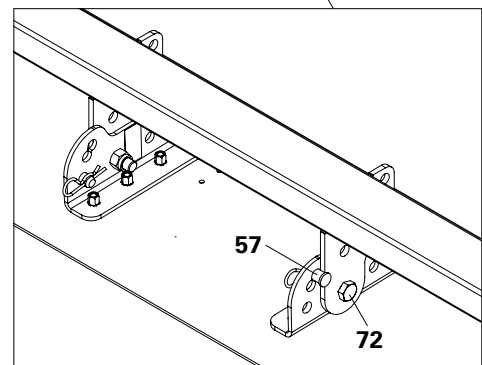

Fig. C1.18b

Assembly of the Screen Element and Telescopic Screen

Assembly of the Screen Adapter takes place in the same way as for the enclosure post and Climbing Rail.

Alternatively, it is always possible to use a Bolt M20x90 with Nut instead of a Fitting Pin and Cotter Pin.

Assembly positions

Assembly of the Screen Adapter usually takes place at the top hole of the enclosure post or Climbing Rail. Mount the additional Screen Adapters in every 10th hole of the enclosure post or Climbing Rail.



For assembling the Screen Adapter, only use Nuts fitted with plastic clamping rings!

Components

2	Climbing Rail-2 LPS
21	Screen Element DX LPS
22	Telescopic Screen DX LPS
24	Screen Adapter Single LPS 60
25	Screen Adapter Double LPS 60
26	Screen Adapter Telescope-2 LPS
27	Screen Adapter Combi LPS 60
29	Edge Screen Adapter Telescope LPS

Assembly principle:
with Screen Adapter Combi (27)
Telescoping ≤ 87 cm.

with Screen Adapter Double (25) and
Screen Adapter Telescope (26)
Telescoping ≤ 105 cm.

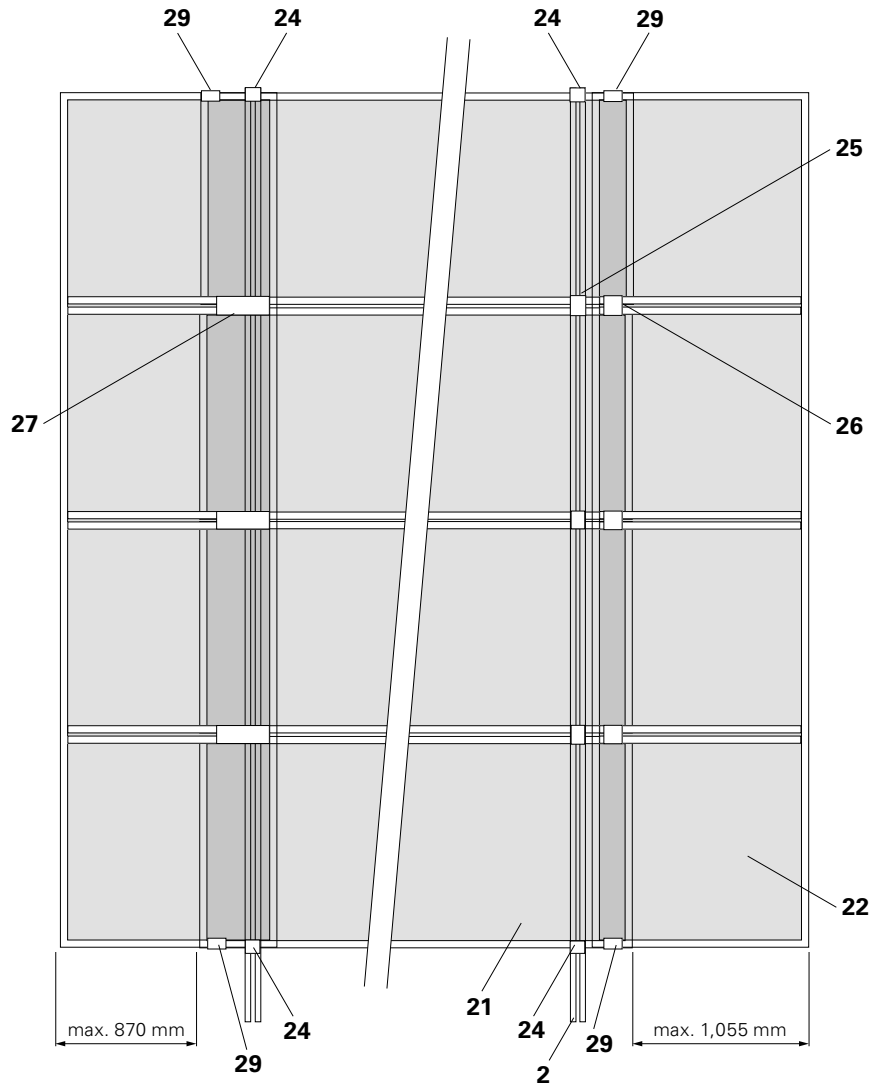

Mounting the Screen Adapter Single LPS 60 (24)

1. Remove Nut (24.5), Washer and Clamping Plate (24.2) from the Ring Bolt (24.4).
2. Place Distance Piece (24.1) and Ring Bolt (4) on the Climbing Rail (2).
3. Secure eyelet of the Ring Bolt in Climbing Rail with Fitting P(81) and Cotter Pin (86). (Fig. C1.19)
4. Mount additional Spacers.
5. Position Screen Element (21).
6. Attach Clamping Plate (24.2) to Ring Bolt and place on frames (21.1) of the Screen Element. Place the long side of the Clamping Plate on the Distance Piece.
7. Place Washer and Nut on the Ring Bolt and secure in position with Nut (80 Nm). (Fig. C1.20)

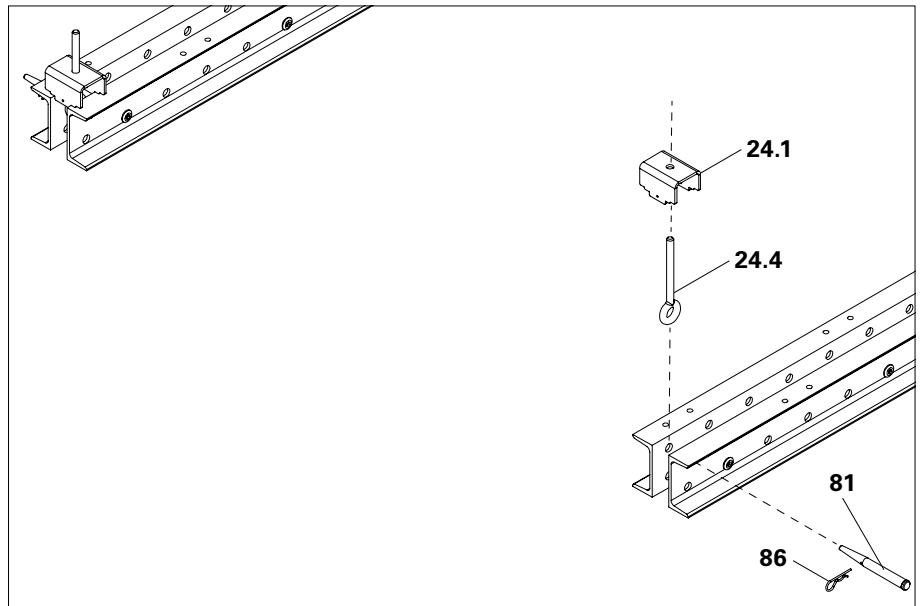

Fig. C1.19

Components

- | | |
|-------------|----------------------------------|
| 21.1 | Screen Element Frame |
| 24.1 | Distance Piece |
| 24.2 | Clamping Plate |
| 24.4 | Ring Bolt |
| 24.5 | Nut |
| 81 | Fitting Pin \varnothing 21x120 |
| 86 | Cotter Pin 4/1 |

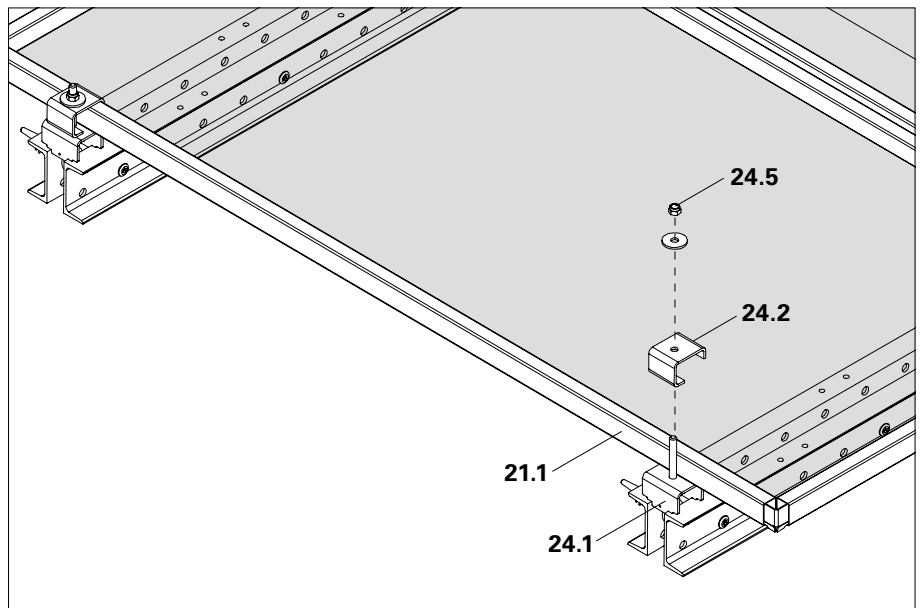

Fig. C1.20

Mounting the Screen Adapter Double LPS 60 (25)

1. Mount Ring Bolt (25.4) and Distance Piece in the same way as the Screen Adapter Single.
2. Position Screen Element (21).
3. Attach Clamping Plate (25.2) on Ring Bolt and place over both frames of the Screen Element.
4. Place Washer and Nut on the Ring Bolt and tighten with 80 Nm.

(Fig. C1.21)

Components

21	Screen Element DX LPS
25	Screen Adapter Double LPS 60
25.2	Clamping Plate
25.4	Ring Bolt
25.5	Washer and Nut

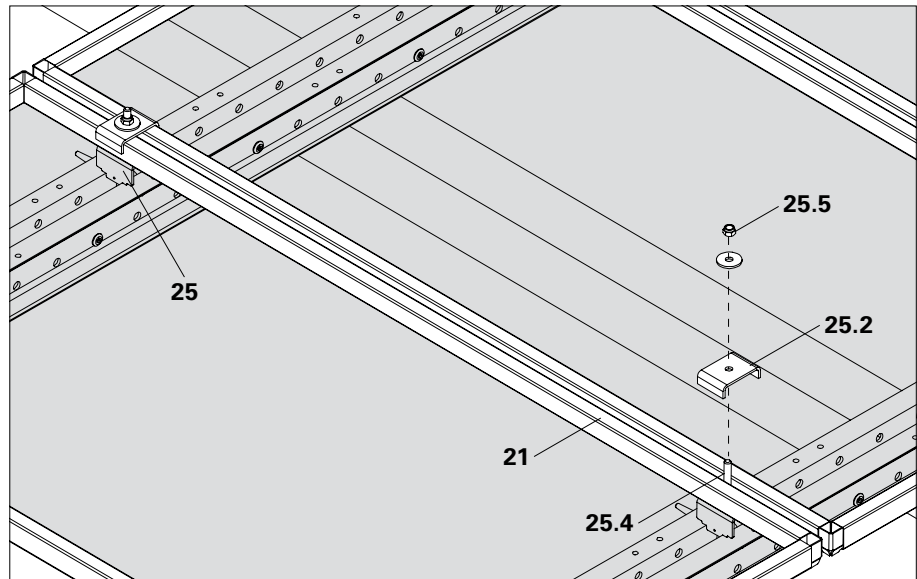

Fig. C1.21

Mounting Screen Element under the Platform Cantilever Beam

1. Insert Screen Element (21) on the Platform Cantilever Beam (32) under the distance plate (32.2).
2. Place the other side of the Screen Element on the Distance Piece (25.1) of a Screen Adapter.
3. If necessary, place Telescopic Screen (22) on the distance plate, mount the other side on the Screen Adapter. (Fig. C1.22c)
4. Screw the Adjusting Bolt (32.1) against the distance plate or Telescopic Screen and thereby clamp the Screen Element in position. (Fig. C1.22b + C1.22c)

Components

- 21** Screen Element DX LPS
- 22** Telescopic Screen DX LPS
- 25.1** Distance Piece for Screen Adapter
- 32** Platform Cantilever Beam LPS
- 32.1** Adjusting Bolt
- 32.2** Distance Plate

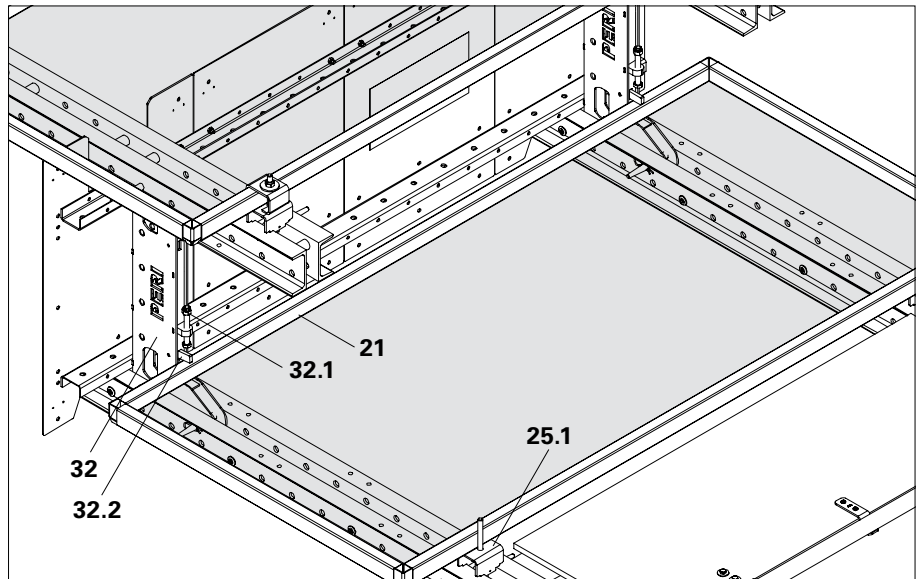

Fig. C1.22

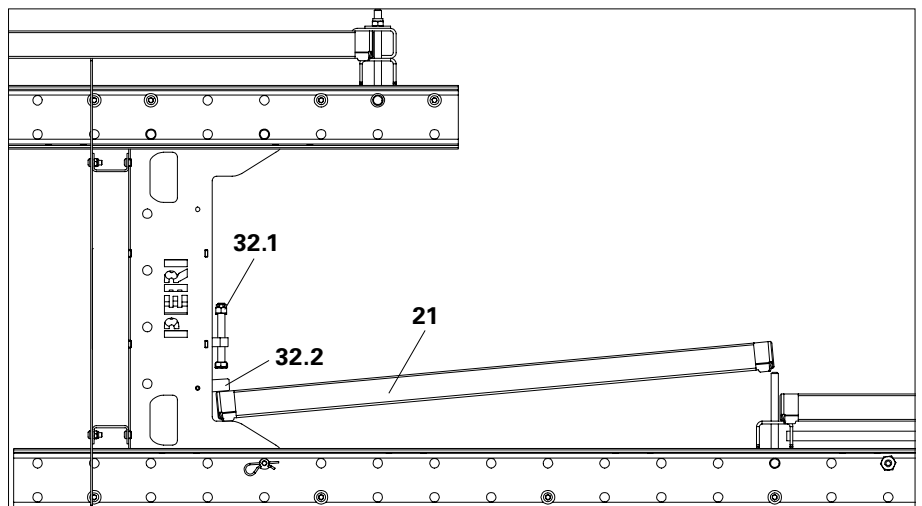

Fig. C1.22a

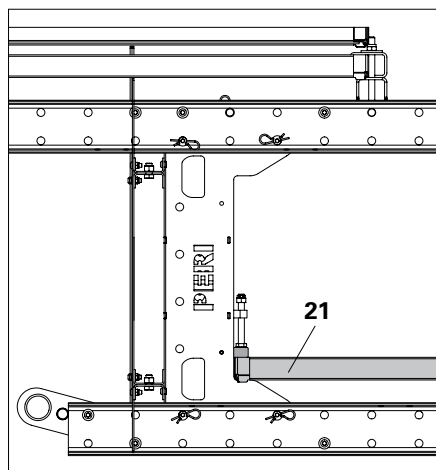

Fig. C1.22b

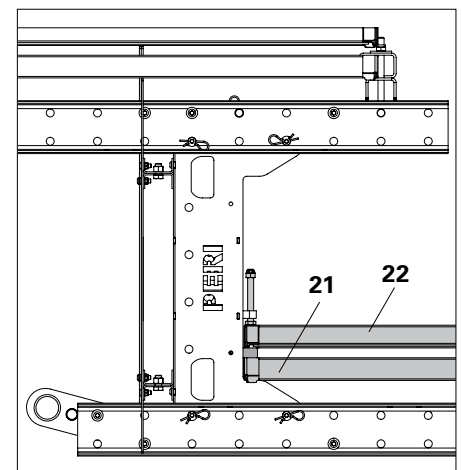

Fig. C1.22c

Mounting the Telescopic Screen

The Telescopic Screens are pre-assembled and slid in to the width of the Screen Elements B_0 (= transport dimension).

Wider enclosures can be completely assembled on the construction site.

For assembling the Telescopic Screen (22), Screen Adapter Combi LPS 60 (27) are mounted.

Optionally, depending on the wind load: mount the Telescopic Screen (22) with Edge Screen Adapter Telescope at the top and bottom ends of the Climbing Rail next to the Screen Adapter Single (24).

Telescopic distance $B_1 \leq 0.87$ m.
(Fig. C1.23)

Alternative

Mount the Screen Element (21) with the Screen Adapter Single (24) and Screen Adapter Double (25).

Mount the Telescopic Screen (22) on the Screen Element with the Screen Adapter Telescope-2 LPS (26).

Optionally, depending on the wind load: mount the Telescopic Screen (22) with Edge Screen Adapter Telescope at the top and bottom ends of the Climbing Rail next to the Screen Adapter Single (24).

Telescopic distance $B_2 \leq 1.05$ m.
(Fig. C1.23)



For assembling the Screen Adapter, only use Nuts fitted with plastic clamping rings!

Components

2	Climbing Rail-2 LPS
21	Screen Element DX LPS
22	Telescopic Screen DX LPS
24	Screen Adapter Single LPS 60
25	Screen Adapter Double LPS 60
26	Screen Adapter Telescope-2 LPS
27	Screen Adapter Combi LPS 60
29	Edge Screen Adapter Telescope LPS

Assembly principle:

with the Screen Adapter Combi (27)

with the Screen Adapter Double (25) and Screen Adapter Telescope (26)

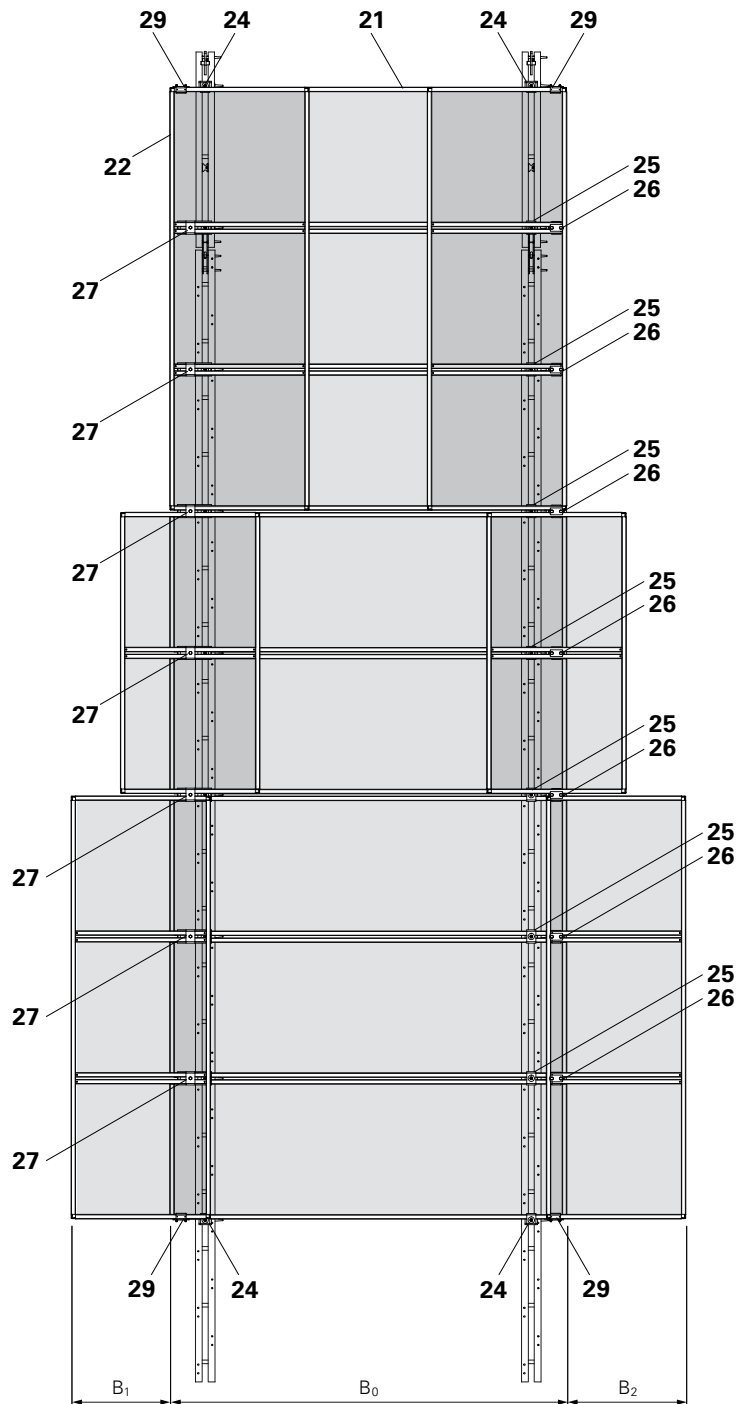

Fig. C1.23

Mounting the Screen Adapter Combi LPS 60 (27)

Telescopic distance ≤ 0.87 m.

1. Install Ring Bolt and Distance Piece in the same way as the Screen Adapter.
2. Position Screen Element (21) on Distance Piece.
3. Attach long Clamping Plate (27.3) to the Ring Bolt (27.4) and place it over both frames (21.1) of the Screen Element.
4. Secure long Clamping Plate with Nut (27.6) M20x8. Tightening torque 80 Nm. (Fig. C1.24)



Pay attention to the mounting direction of the Clamping Plate, long end must point outwards.

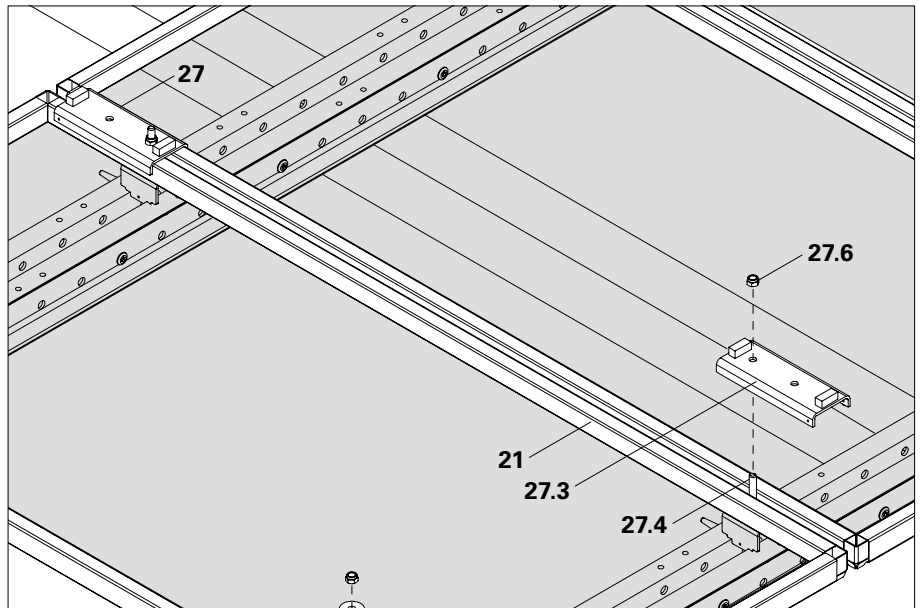

Fig. C1.24

5. Slide the Telescopic Screen (22) into position.
6. Insert the bolt from the Mesh Panel Clamp (27.2) through the Telescopic Screen as well as the long Clamping Plate and secure with Washer and Nut (27.5). Tightening torque 80 Nm. (Fig. C1.25)

Components

21	Screen Element DX LPS
22	Telescopic Screen DX LPS
27	Screen Adapter Combi LPS 60
27.2	Mesh Panel Clamp
27.3	Long Clamping Plate
27.4	Ring Bolt
27.5	Washer and Nut
27.6	Nut

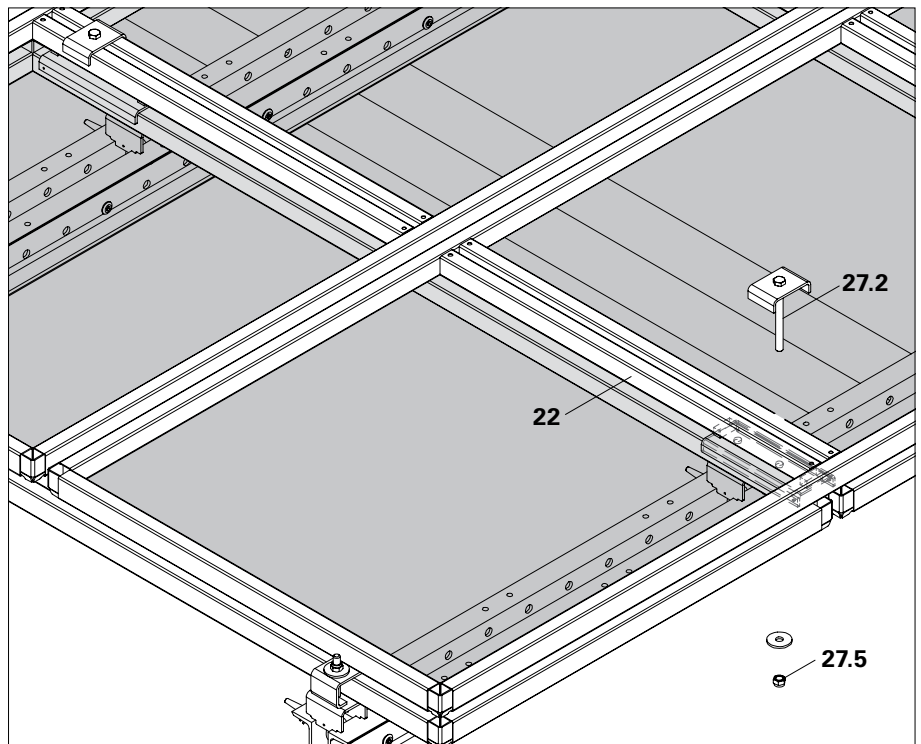

Fig. C1.25

Mounting the Screen Adapter Telescope-2 LPS (26)

Telescopic distance ≤ 1.05 m.

1. Mount Screen Element (21) with Screen Adapter Double LPS 60 (25).
2. Place pressure plate (26.3) of Screen Adapter Telescope on the Screen Element. (Fig. C1.26)

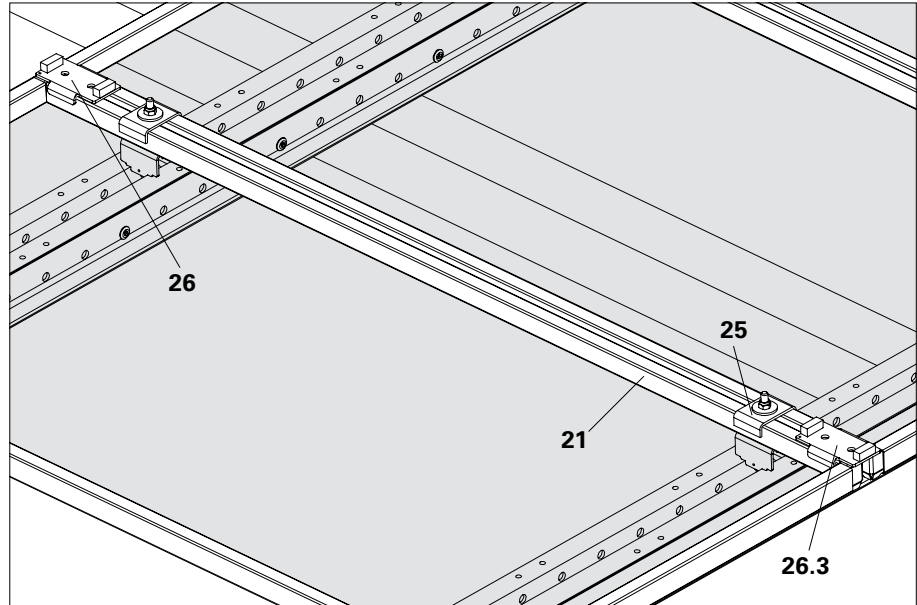

Fig. C1.26

3. Position Telescopic Screen (22).
4. Push screen holder (26.4) through the Telescopic Screen, pressure plate and Screen Element (21), and secure from below with Clamping Plate (26.2) and Nuts. Tightening torque 80 Nm. (Fig. C1.27)

Components

21	Screen Element DX LPS
22	Telescopic Screen DX LPS
25	Screen Adapter Double LPS 60
26	Screen Adapter Telescope-2 LPS
26.2	Clamping Plate
26.3	Pressure Plate
26.4	Screen Holder

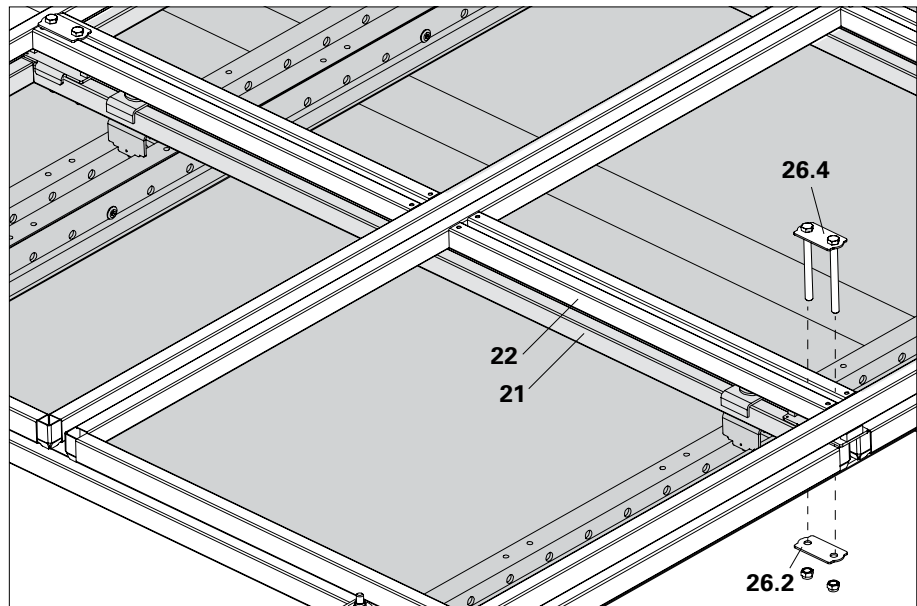

Fig. C1.27

Mounting the Edge Screen Adapter Telescope LPS

Optional, required depending on the wind load.

1. Unscrew the clamping screws (29.1) a few turns.
2. Insert End Screen Adapter (29) at the corners, from above or from below, over the edge frames of the Screen Element (21) and Telescopic Screen (22).
3. Hand-tighten clamping screws to the screen.
(Fig. C1.28)



Do not tighten the attachment of the sliding clamping plate (29.2). The clamping plate must remain slideable on the inside in order to ensure a uniform clamping effect on both edge profiles. If inadvertently tightened, loosen the Nut by half a turn.

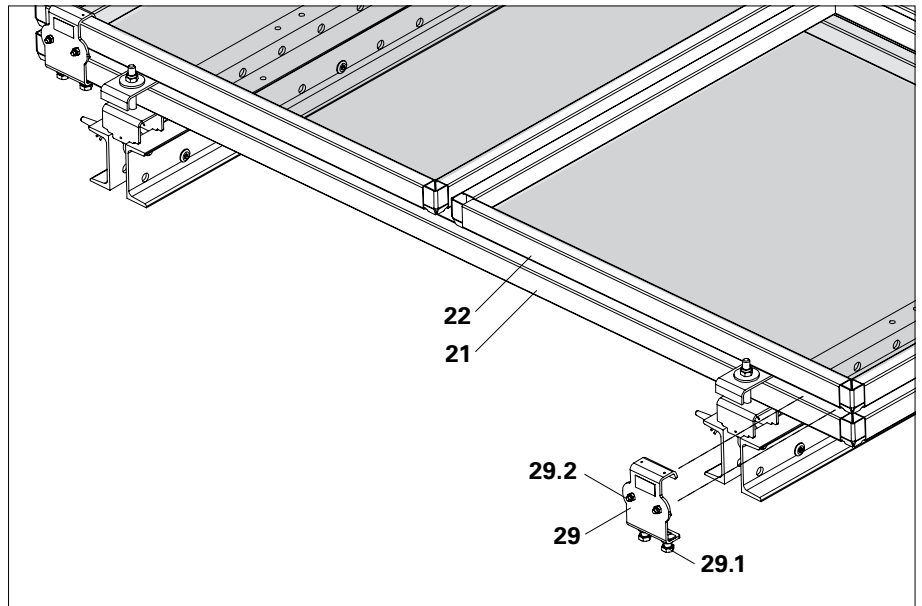

Fig. C1.28

Mounting the Telescopic Scaffold Tube LPS

For assembling the Telescopic Screen, pull out approx. 10 cm.

1. For supporting the Foldable Covers in the area of the Telescopic Screen, insert a Telescopic Scaffold Tube LPS (44) into the scaffold tube (43).
2. Attach Clip M10 (44.1) to the Telescopic Screen.
(Fig. C1.29 + C1.29a)

Components

21	Screen Element DX LPS
22	Telescopic Screen DX LPS
29	Edge Screen Adapter Telescope LPS
29.1	Clamping Screws
29.2	Bolted Connection for Distance Plate
43	Scaffold Tube \varnothing 48.3 x 3.2
44	Telescopic Scaffold Tube LPS

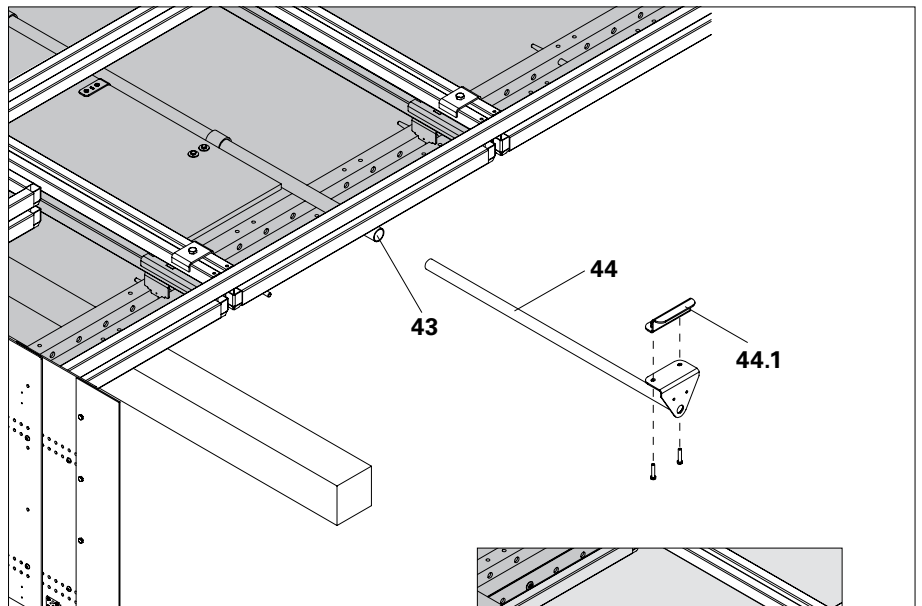

Fig. C1.29

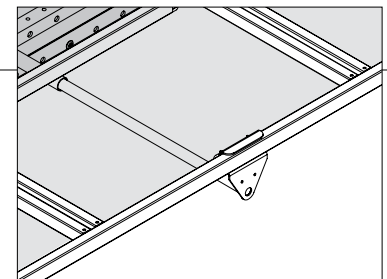

Fig. C1.29a

Mounting the Screen Adapter Stacking LPS 60 (31)

With attachment point for crane, in order to horizontally move climbing enclosure, e.g. for loading onto trucks.

Can be used instead of Screen Adapter Double or Screen Adapter Combi.

Max. telescopic distance = 87 cm.

1. Mount Distance Piece and long Clamping Plate in the same way as the Screen Adapter Combi.
2. Position Telescopic Screen (22).
3. Push bolts for the suspension (31.6) through the Telescopic Screen and long Clamping Plate, and connect tightly with lock plate (31.7) and Nuts (31.5). Tightening torque 80 Nm. (Fig. C1.28 + C1.29)

When using the Screen Adapter Stacking LPS on enclosures without a Telescopic Screen, attach the suspension-directly onto the Clamping Plate.



Follow Instructions for Use for the Screen Adapter Stacking LPS 60!

Components

21	Screen Element DX LPS
22	Telescopic Screen DX LPS
31	Screen Adapter Stacking LPS 60
31.3	Long Plamping Plate
31.5	Nut
31.6	Suspension
31.7	Lock Plate

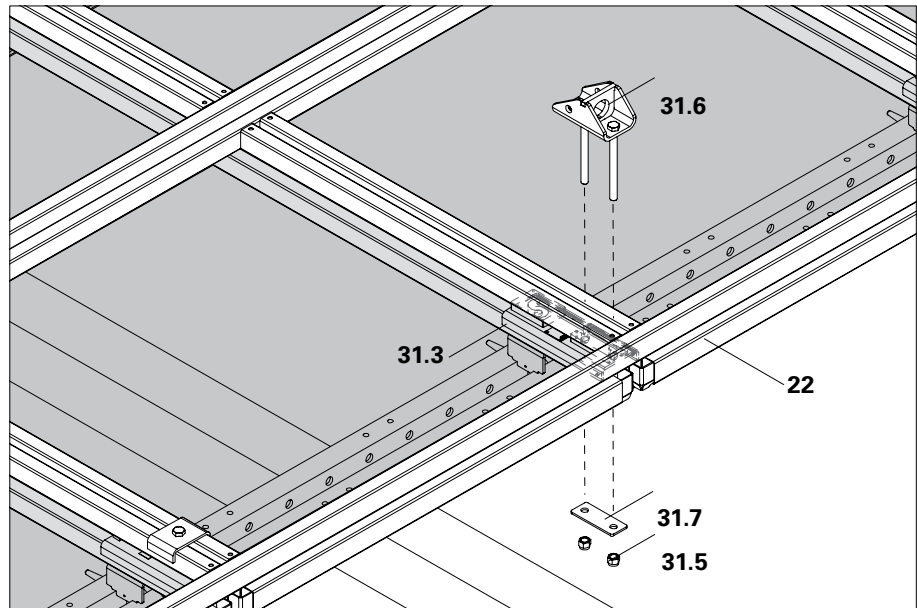

Fig. C1.28

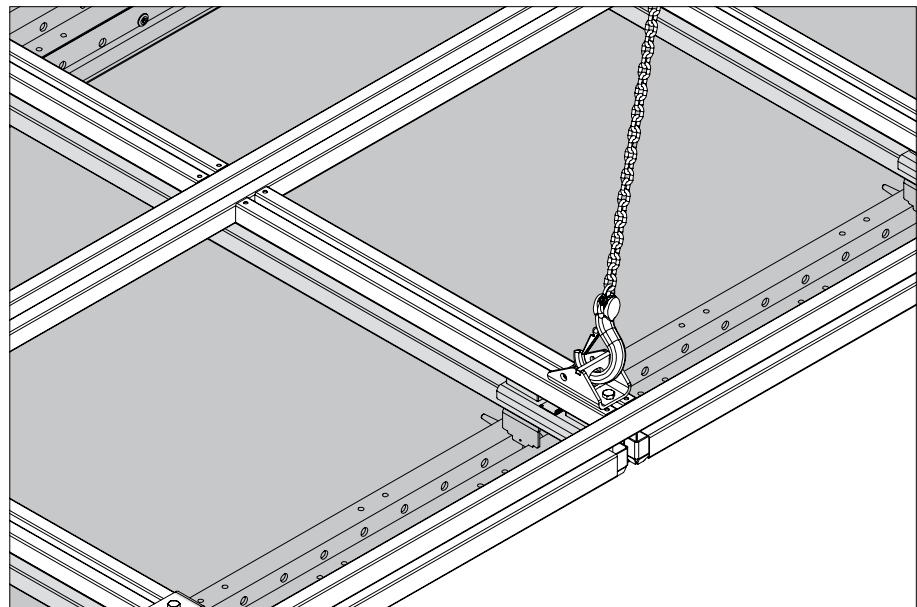

Fig. C1.29

Assembly of the Platform Extension

1. Attach Platform Beam LPS 173 (34.1) laterally to the available platform beam using Bolts 4017 M16x40-8.8 (72) and Nuts ISO 7040 M16-8 (72.1). Distance $S \geq 250$ mm (Fig. C2.01)
2. Depending on the width of the platform extension, centrally mount an additional 3rd Platform Beam on the Platform Covers.
3. Install timber as trimmer beam. See Section "Platform Extension" on Page 44.
4. Mount Platform Covers (35.5) on Platform Beams using Oval-Head Screws ISO 7380 M10x25-10.9 (73) and Nuts ISO 7040 M10 (73.1). (Fig. C2.02 + C2.03)
Position projecting Platform Covers on both sides. See Section "Platform Extension" on Page 44.

Components

34.1	Platform Beam LPS 173
35.5	Platform Cover LPS 37.5 x 107.5
72	Bolt ISO 4017 M16x40-8.8
72.1	Nut ISO 7040 M16-8
73	Oval-Head Screw ISO 7380 M10x25-10.9
73.1	Nut ISO 7040 M10

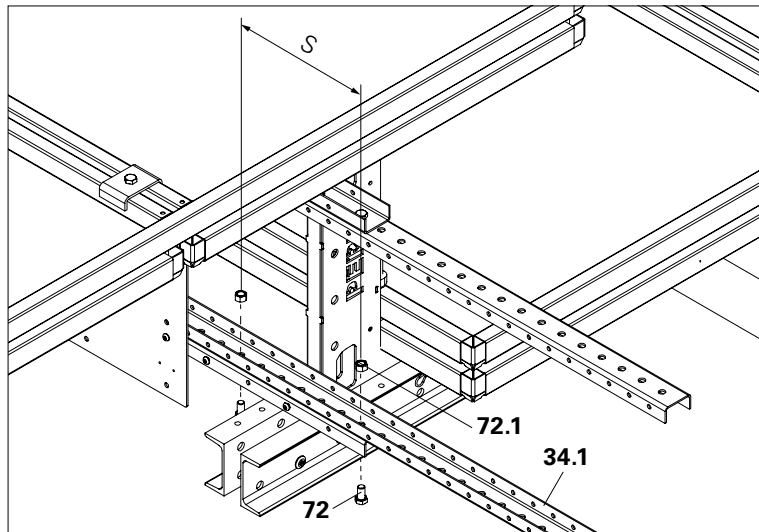

Fig. C2.01

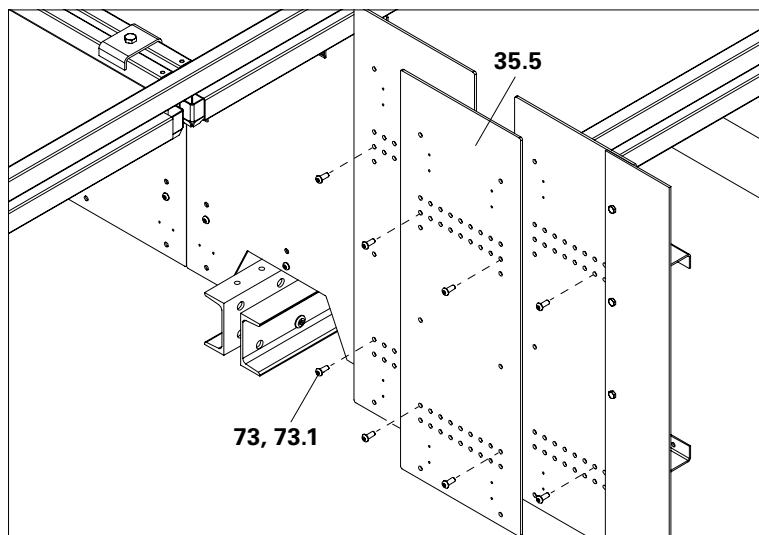

Fig. C2.02

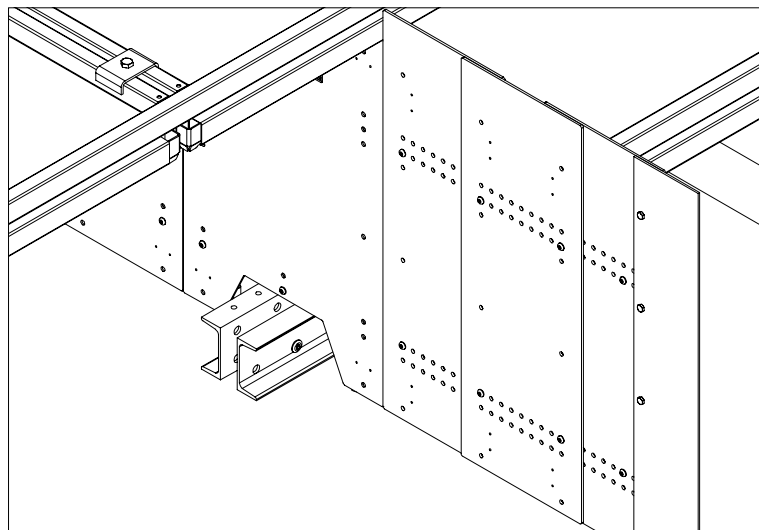

Fig. C2.03

Assembly of the Toe Boards

1. For platform extensions, pre-drill with \varnothing 5 mm the Platform Covers in order to screw on the Angle Connector (82). Take into account an edge distance of 3 cm for the Toe Boards.
 2. Secure Angle Connector (82) to Platform Cover using SPAX 6 x 20 (83).
 3. Fix Toe Boards (37, 37.1) to corners with TSS Torx 6x60 (84.1).
 4. Mount Toe Boards to Angle Connectors using SPAX 5x35 (84).
 4. Attach Toe Boards above the Climbing Rail (37.2) by means of TSS Torx 4.5x60.
- (Fig. C2.04)

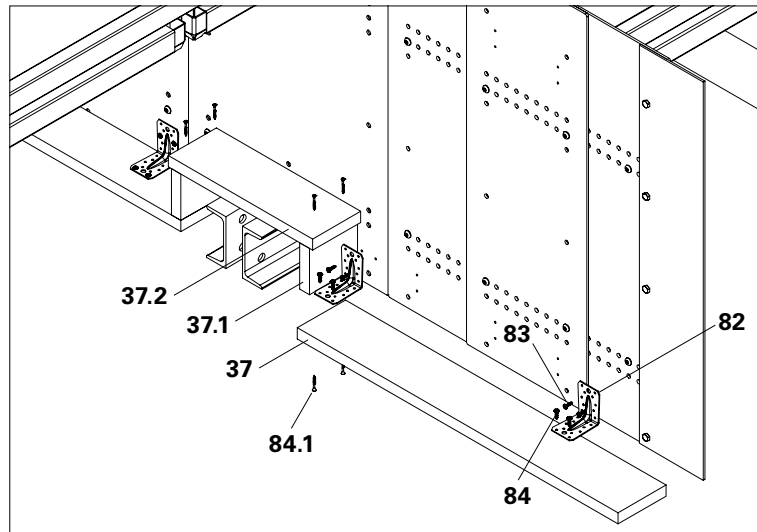

Fig. C2.04

Telescoping the Screen

1. Loosen the Nut (27.5) of the Screen Clamping Plate on the Screen Adapter Combi (27) or loosen the Screen Adapter Telescope by a few turns.
 2. If fitted, loosen the clamping screws of the Edge Screen Adapter by a few turns.
 3. Extend the Telescopic Screen to the required dimension. If the Screen Adapter Telescope is used, push the Telescopic Screen slightly downwards on the outside. Lift Screen Frame twice over the Ring Bolt of the Screen Adapter.
 4. Re-tighten all Bolts and Nuts.
- (Fig. C2.05)

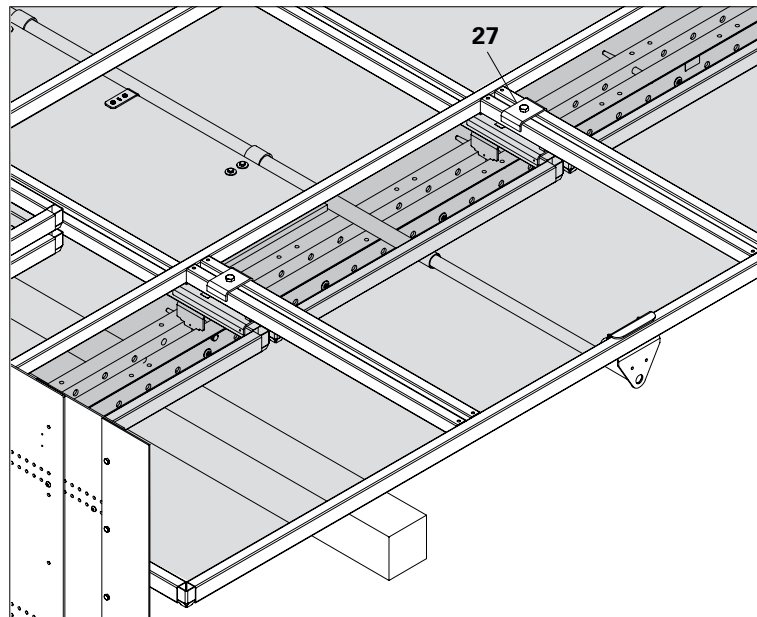

Fig. C2.05

Components

- 27** Screen Adapter Combi LPS 60
- 37** Toe Board
- 82** Toe Board Angle 90°
- 83** SPAX 6x20 TX30
- 84** SPAX 5x25 SK-TX 25
- 84.1** TSS Torx 6x60
- 73** Oval-Head Screw ISO 7380 M10x25-10.9
- 72.1** Nut ISO 7040 M10

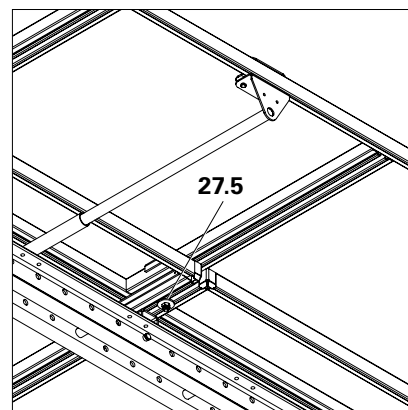

Fig. C2.05a

View from below

Assembly of the Telescopic Screen on the Front Side of the Platform

Screen Adapter Corner LPS (28)

For fixing Telescopic Screens LPS at right angles to other Screen Elements.

Assembly of the Screen Adapter Corner takes place on the double strut of the Telescopic Screen (22) or on the struts of two adjacent standard Screen Elements.

1. Position Screen Adapter Corner flush with the screen corner.
2. Turn Screen Anchor Plate (28.1) by 90° with ring, tighten with Nut M16 and secure with lock nut. (Fig. C2.06)
3. Insert double struts of the Telescopic Screen to be mounted at right angles into the Screen Anchor Plate.
4. Turn Screen Anchor Plate (28.1) by 90° with ring (28.2).
5. Position and align the Telescopic Screen.
6. Tighten Screen Anchor Plate with Nut M16 (28.3) and secure with lock nut. (Fig. C2.07)

Components

22	Telescopic Screen DX LPS
28	Screen Adapter Corner LPS
28.1	Screen Anchor Plate
28.2	Ring
28.3	Nut M16

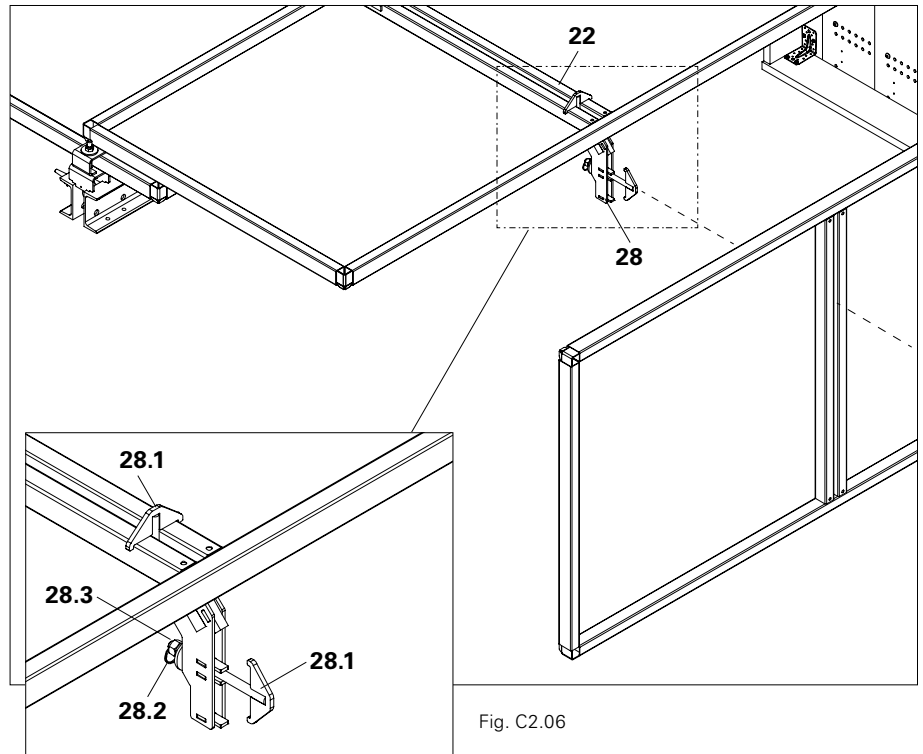

Fig. C2.06

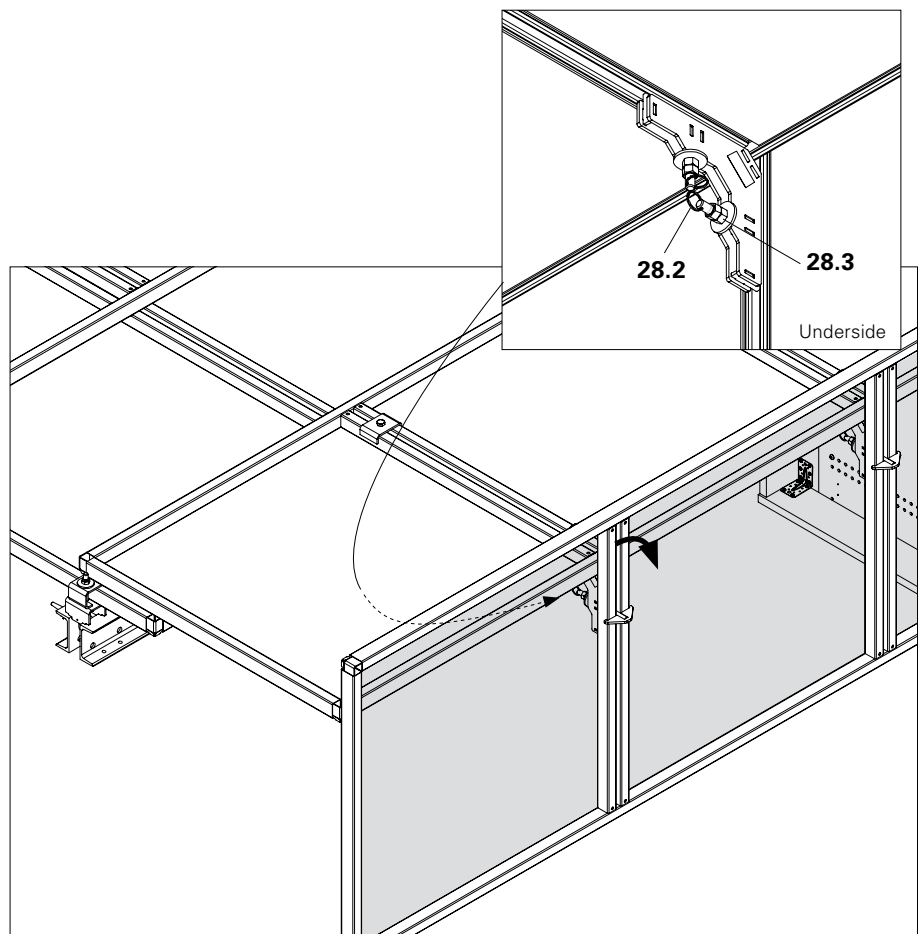

Fig. C2.07

Edge Screen Adapter Telescope LPS (29)

1. Unscrew two clamping screws (29.1) a few turns.
 2. Insert End Screen Adapter at the corners, from above or from below, over the edge frames of the Screen Element (21) and Telescopic Screen (22).
 3. Hand-tighten clamping screws (29.1) to the screen.
- (Fig. C2.08 + C2.09)



Do not tighten the attachment (29.2) of the sliding clamping plate. The clamping plate must remain slideable on the inside, in order to ensure a uniform clamping effect on both edge profiles. If inadvertently tightened, loosen the Nut by half a turn.

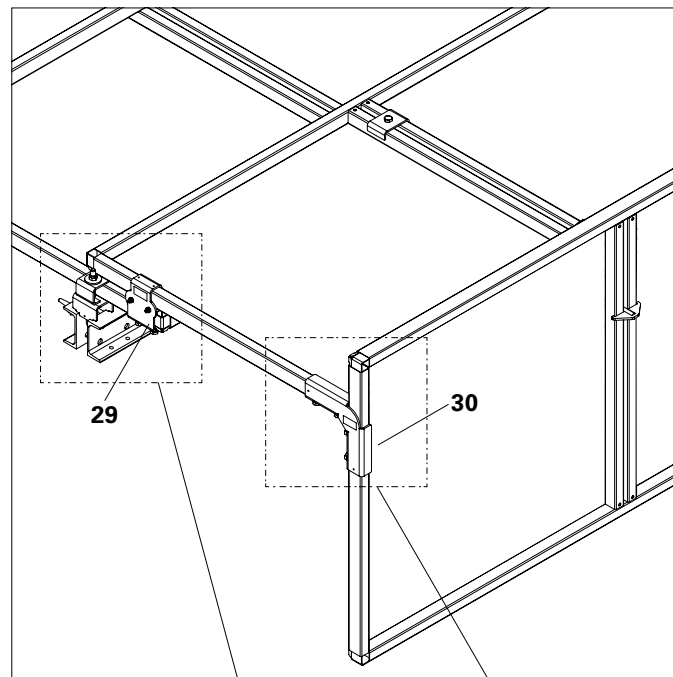

Fig. C2.08

Edge Screen Adapter Corner LPS (30)

For edge attachment of Telescopic Screens at right angles to other Screen Elements.

1. Unscrew four clamping screws (30.1) a few turns.
 2. Insert End Screen Adapter at the corners, from above or from below, over the edge frames of the Screen Element and Telescopic Screen.
 3. Hand-tighten clamping screws to the screen.
- (Fig. C2.08 + C2.10)

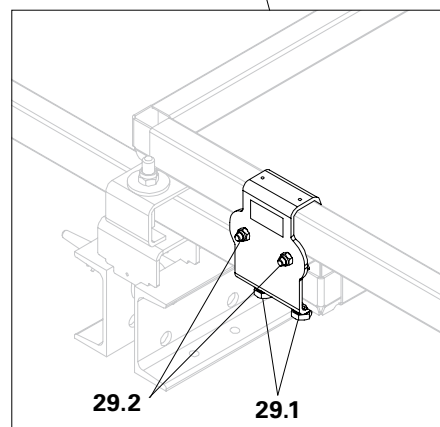

Fig. C2.09

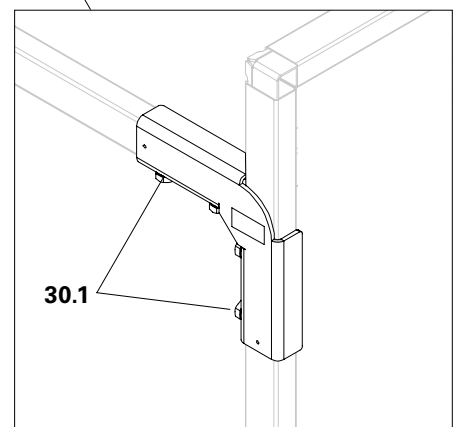

Fig. C2.10

Components

- 29** Edge Screen Adapter Telescope LPS
- 29.1** Clamping Screws
- 29.2** Bolted Connection for Distance Plate
- 30** Edge Screen Adapter Corner LPS

Gap Covering with Draw-in Profiles

Close the gap, which is required for climbing, between the Screen Elements. See following pages for permissible screen spacings.

Assembly

1. Mount Cover Clip Profile (63) on the vertical frame (21.1) of the Screen Element. First, place the short angle (63.1) on the outside of the Screen Element, then snap open the long angle (63.2). (Fig. C2.11 + C2.11a)
2. Cut the Draw-In Profile LPS 20/55 (65) or 18/93 (63.4) diagonally at the top and bottom according to requirements, which then allows the screw in Step 4 to be used.
3. Insert Draw-In Profile into the Cover Clip Profile.
4. Secure the Draw-In Profile at the top and bottom using Drilling Screw ST 5.5 x 45 – TX30 GEO (66), in order to prevent sliding out. Screw Drilling Screw through Draw-In Profile, Cover Clip Profile and Screen Element frame (21.1). (Fig. C2.11b)



Apply formwork oil to Draw-In Profile to make it easier to pull in.

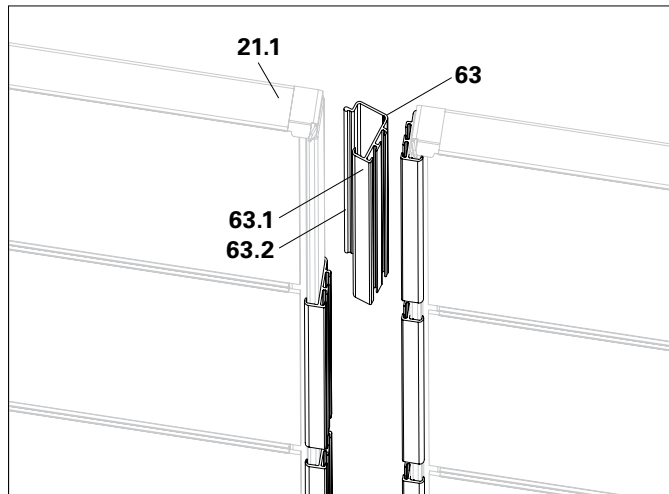

Fig. C2.11

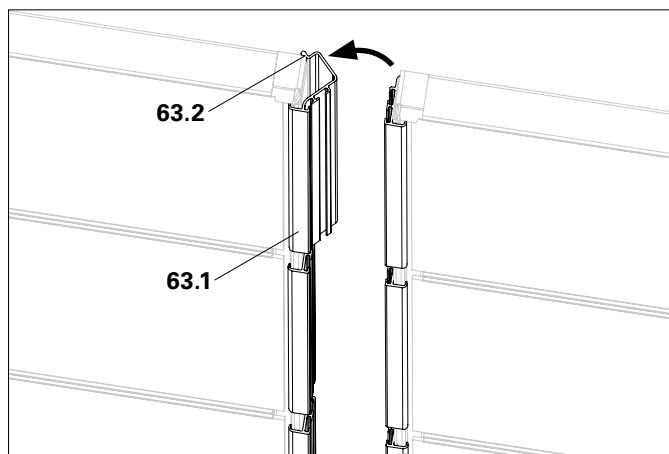

Fig. C2.11a

Components	Item no.
21	Screen Element DX LPS
21.1	Screen Element Frame
63	Cover Clip Profile LPS 110
65	Draw-in Profile LPS 20/55
66	Screw ST 5.5 x 45 - TX30710262

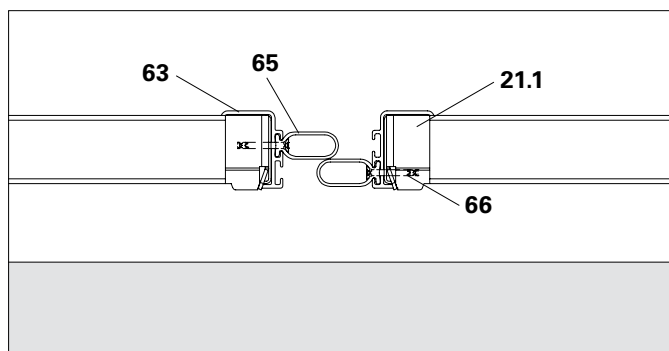

Fig. C2.11b

Selecting the Draw-In Profile

Depending on the application, mount the gap covering on one or both sides of the climbing enclosure.

Use inner or outer profile rail of Cover Clip Profile.

Units straight next to each other

Install Draw-In Profile LPS 20/55 (65) offset on both sides. (Fig. C2.12a)

Alternatively:

Mount Draw-In Profile LPS 18/93 (64) on one side. (Fig. C2.12b)

For larger spacings, install Draw-In Profile LPS 18/93 (64). (Fig. C2.12c)

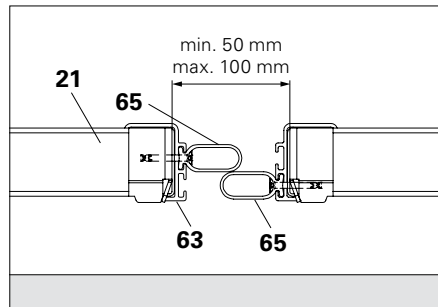

Fig. C2.12a

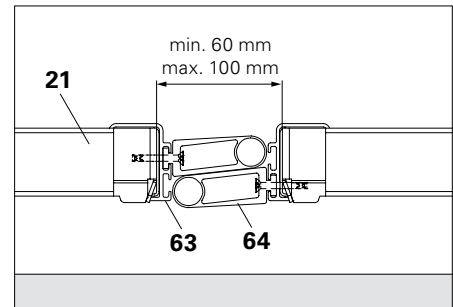

Fig. C2.12b

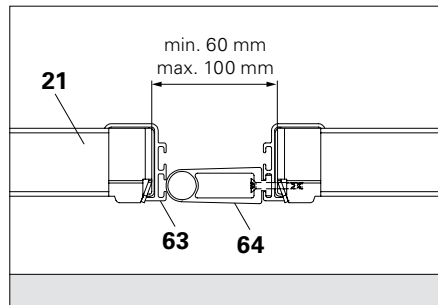

Fig. C2.12c

Units on external corners

In the area of the Climbing Rail:

Mount Draw-In Profile LPS 20/55 (65) on the inside on both sides. (Fig. C2.12d)

In the area of the platforms:

Mount Draw-In Profile LPS 18/93 (64) on the inside on both sides. (Fig. C2.12e)

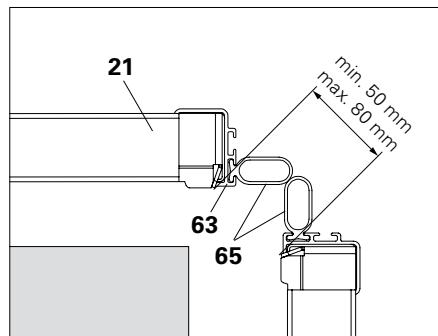

Fig. C2.12d

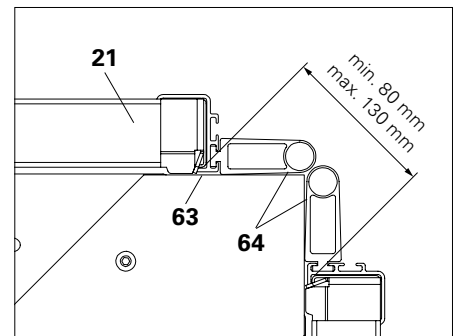

Fig. C2.12e

Units on internal corners

In the area of the Climbing Rail and enclosure post, install the Draw-In Profile LPS 20/55 (65) on both sides on the outside. (Fig. C2.12f)



– Drilling screw not always shown.

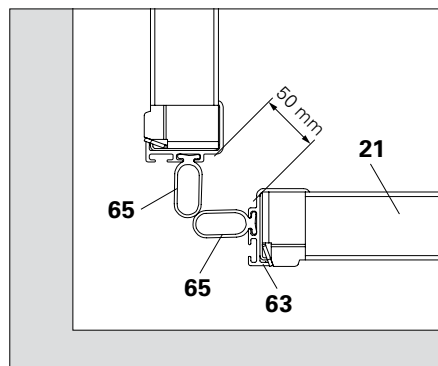

Fig. C2.12f

Components

21	Screen Element DX LPS
63	Cover Clip Profile LPS 110
64	Draw-in Profile LPS 18/93
65	Draw-in Profile LPS 20/55

Gap Covering with Cover Strip Rubbers

1. Cut Cover Strip to required size.
2. Pre-drill (\varnothing 8 mm) Cover Strip.
3. Mount Cover Strips with cable ties through the wire mesh of the Screen Element.

Assembly on the Telescopic Screen takes place in the same way.

Units straight next to each other

Mount Cover Strip LPS 0.20 (62) with cable binder (75).

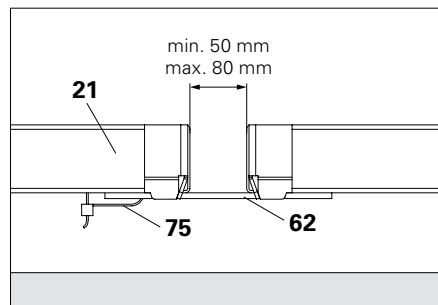

Fig. C2.13a

Units on external corners

In the area of the Climbing Rail and enclosure post, mount Cover Strip LPS 0.20 (62) on both sides using cable binder.

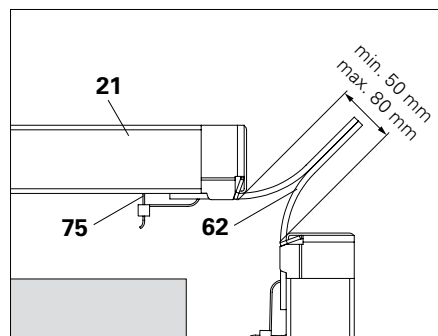

Fig. C2.13b

Units on the internal corner

In the area of the Climbing Rail and enclosure post, mount Cover Strip LPS 0.20 (62) on both sides using cable binder.

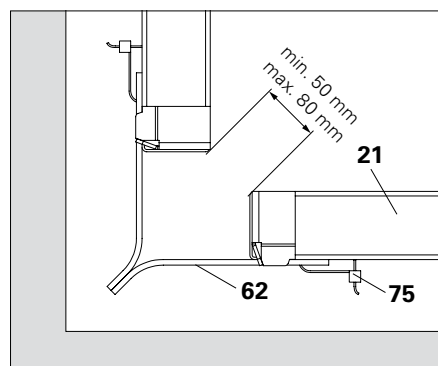

Fig. C2.13c

Components

21	Screen Element DX LPS
62	Cover Strip LPS 0.20 x 10 m
75	Cable Binder PA 6.6 SW 203x7.6

Setting Up the Climbing Unit

Straight climbing units (Version 1)

Fold up the pre-assembled Foldable Covers and attach to the Screen Elements.

1. Remove or secure all loose components.
2. Install Crane Eye BR-2 2.5 t, see Section "Assembly of Attachment Points" on Page 69.
3. Installing Compression Brace, see Section "Moving by Crane" on Page 41.
4. Attach guide ropes to the climbing enclosure.
5. Attach crane lifting gear to Crane Eye BR-2.
6. Align and lift the climbing unit. (Fig. C3.01)



Permissible load per Crane Eye BR-2 2.5 t: max. 25 kN.

For moving heavy climbing units, use Lifting Beam 10 t. A compression brace is, therefore, not required.

Follow Instructions for Use for the Lifting Beam 10 t and Crane Eye BR-2!

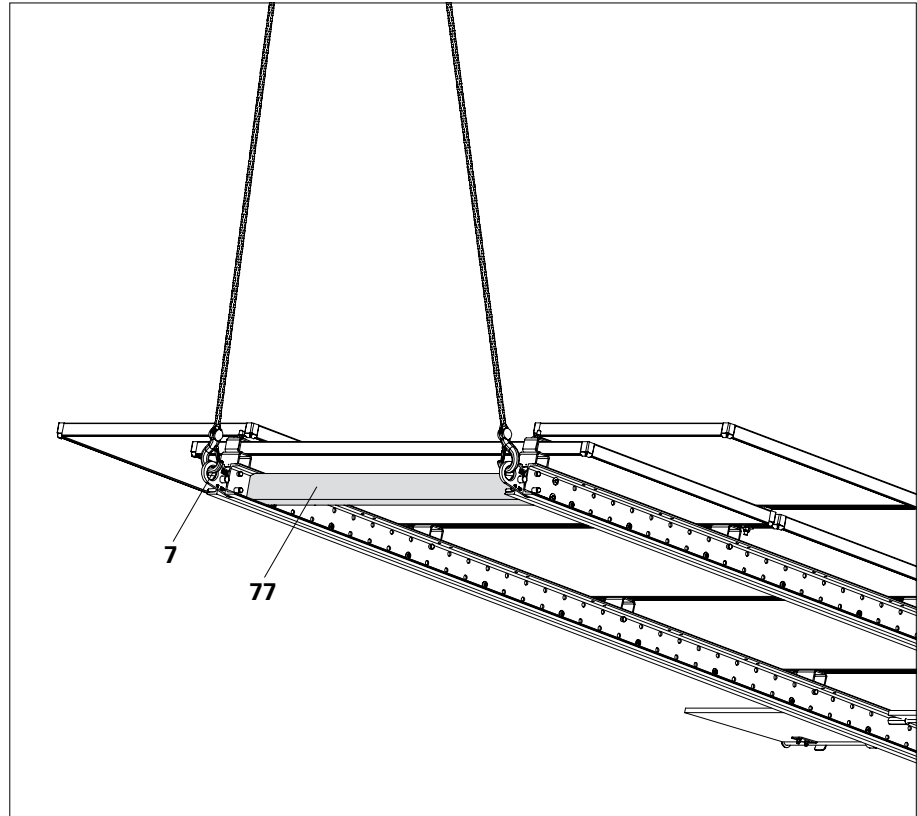

Fig. C3.01

Components

- | | |
|-----------|----------------------|
| 7 | Crane Eye BR-2 2.5 t |
| 77 | Timber 120/100 mm |

Climbing units with working platform (Version 2)

Fold up the pre-assembled Foldable Covers and attach to the Screen Elements.

1. Remove or secure all loose components.
2. Attach Crane Eye BR-2 2.5 t to enclosure post, see Section "Assembly of Attachment Points" on Page 69. Distance to working platform approx. 2.0 m.
3. Adjust Lifting Beam 10 t (9) to suit the climbing rail spacings.
4. Attach chain lifting gear to Crane Eyes. Lead chains along the space of the enclosure post.
5. Secure guide ropes to the climbing enclosure.
6. Align and lift the climbing unit. (Fig. C3.02 + C3.02a)



Follow Instructions for Use for the Lifting Beam 10 t and Crane Eye BR-2!

Components

- | | |
|-----------|----------------------|
| 7 | Crane Eye BR-2 2.5 t |
| 9 | Lifting Beam 10 t |
| 77 | Timber 120/100 mm |

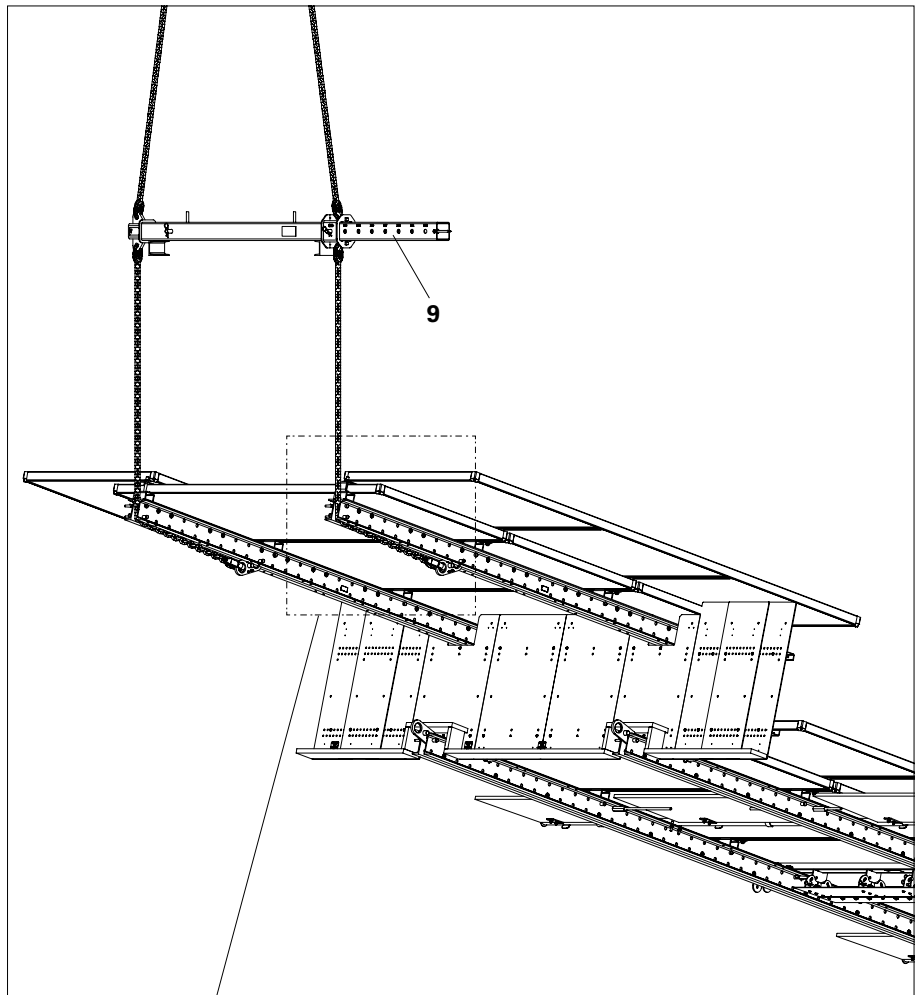

Fig. C3.02

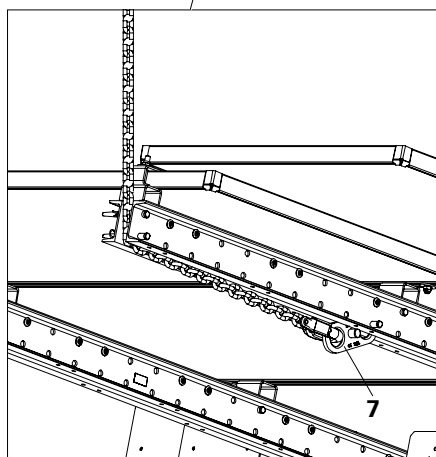

Fig. C3.02a

Assembly of the Climbing Unit



Warning

- Risk of falling from unsecured building edges. A fall can result in serious injury or even death.
 - ⇒ Install guardrails.
 - ⇒ Use personal protective equipment to prevent falling from a height (PPE).
- During assembly on the construction site, components may fall to the ground and hit people below. This could lead to serious injuries or even death.
 - ⇒ Cordon off areas of risk under the working areas.
 - ⇒ Release the climbing unit from the crane lifting gear only when all climbing shoes are closed and the climbing unit fully rests on the bottom Slab Shoes.

Preparations

1. Mount required guardrails on all leading slab edges or ensure that PPE is used.
2. Attach top (10a) and bottom Slab Shoes (10b) to the slab.
3. Adjust the height of the bottom Slab Shoe in order to ensure accurate alignment of the screens.
4. Open the folding runners (10.3) of the Slab Shoes (10a) and (10b), see Section "Opening and Closing the Rail Guidance Shoe" on Page 112.
5. Lock the climbing pawl (10.2) of the top Slab Shoe (10b), in order to prevent inadvertent locking into place, in the event $h_B = n \times 50 \text{ cm}$. See Section "Activating and Deactivating the Climbing Pawl" on Page 113. (Fig. C3.03)

Components

-
- 10** Slab Shoe-2 LPS 10 t
 - 10.2** Climbing Pawl
 - 10.3** Folding Runners
-

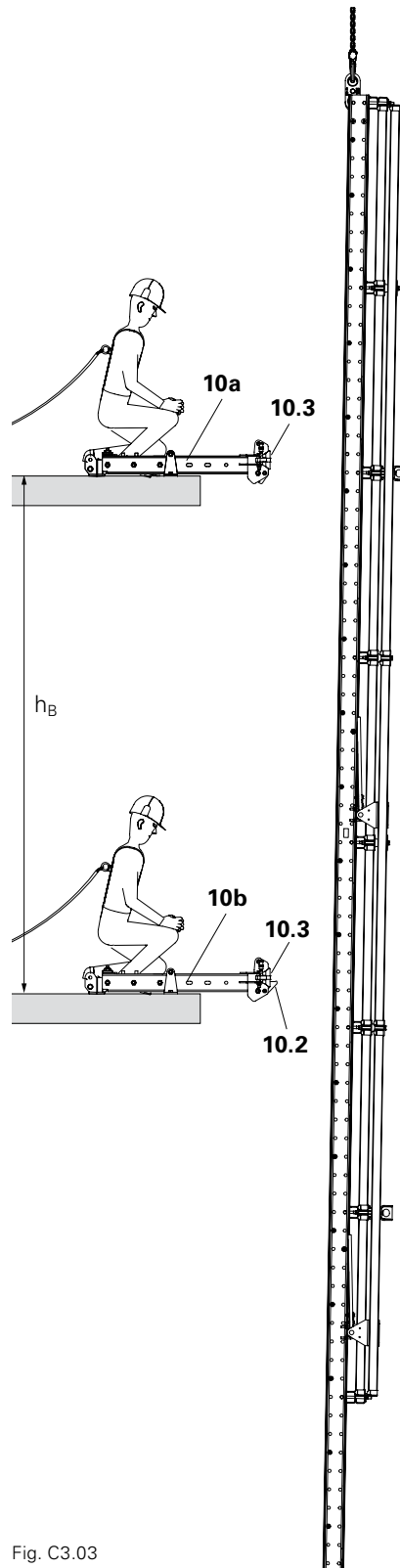

Fig. C3.03

Installation Version 1



Warning

Parts of the body can get caught between the Climbing Rail and Slab Shoe and become trapped. This can cause serious injury.

- ⇒ Do not take hold of anything between the Rail Guidance Shoes and Climbing Rails.
- ⇒ Use the Guide-in Tool.
- ⇒ Guide the climbing enclosure with ropes.



- Suspend the climbing enclosure so that the chain lifting gear can be detached from a safe position. Then climb.
- In order to facilitate threading through, do not fasten the guide brackets (10.6) until the climbing enclosure has been mounted.

Assembly

1. Insert Climbing Rails into the opened bottom Climbing Shoes (10b). Use the Guide-in Tool.
2. Close the folding runners (10.3) of the bottom Climbing Shoe and secure, see Section "Opening and Closing the Rail Guide" on Page 112.

Components

-
- 10** Slab Shoe-2 LPS 10 t
 - 10.2** Climbing Pawl
 - 10.3** Folding Runners
 - 10.6** Guiding Bracket
-

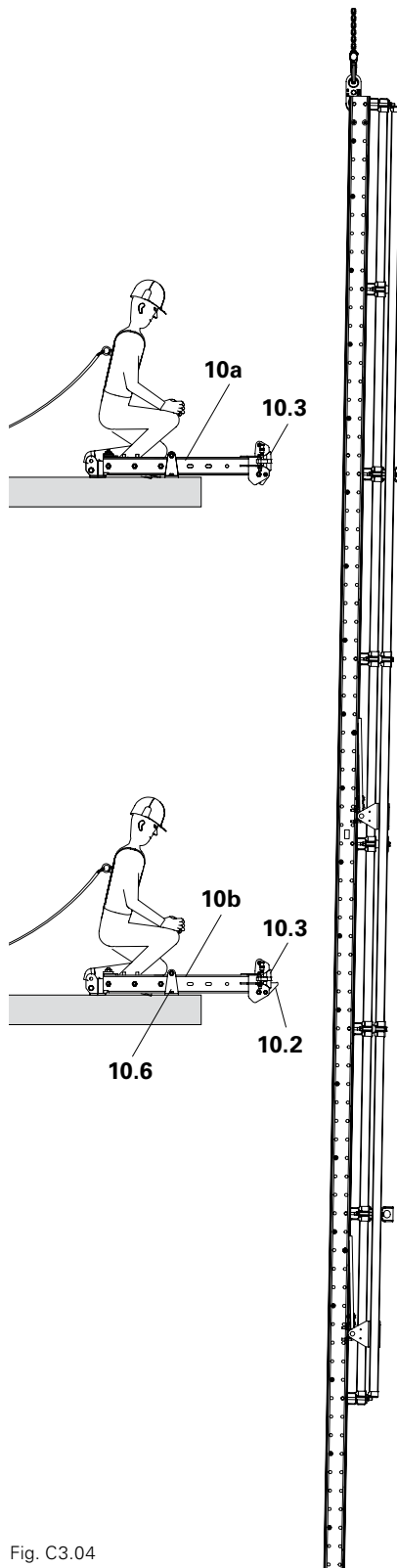

Fig. C3.04

3. Insert Climbing Rail into the top Climbing Shoe (10a) using the Guide-In Tool (98). (Fig. C3.05a)
4. Close the folding runners (10.3) of the top Climbing Shoe and secure.
5. Remove Guide-in Tool.
- 6.
7. Align climbing unit.
8. Tighten guiding brackets (10.6) of all Slab Shoes.
9. Completely relieve crane and release crane lifting gear from a safe position. (Fig. C3.05)

Components

- | | |
|-------------|----------------------|
| 2.1 | Spacer LPS 52 |
| 10 | Slab Shoe-2 LPS 10 t |
| 10.2 | Climbing Pawl |
| 10.3 | Folding Runners |
| 10.6 | Guiding Bracket |
| 98 | Guide-in Tool |

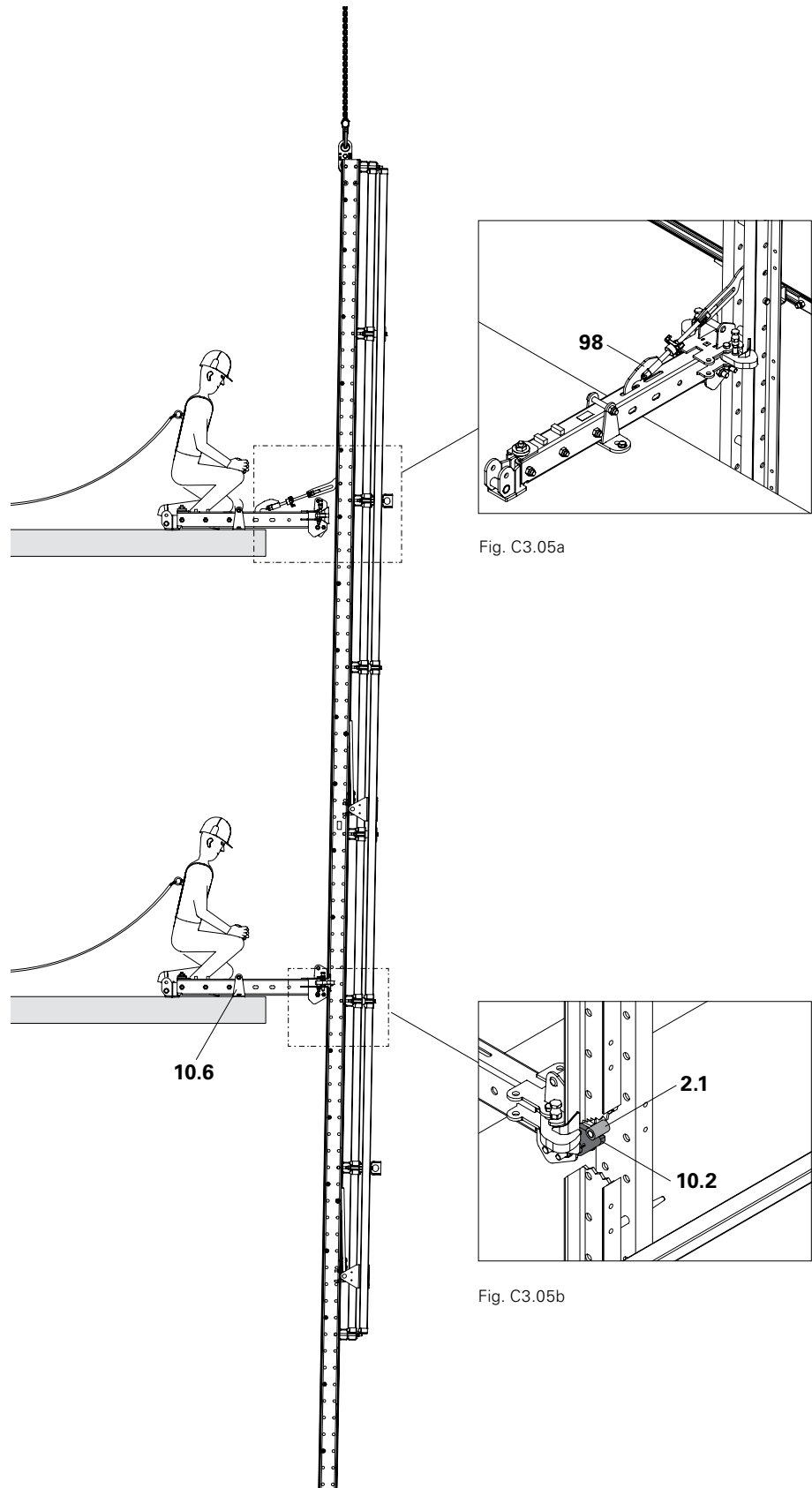

Fig. C3.05

Installation Version 2



Warning

Parts of the body can get caught between the Climbing Rail and Slab Shoe and become trapped. This can cause serious injury.

- ⇒ Do not take hold of anything between the Rail Guidance Shoes and Climbing Rails.
- ⇒ Use the Guide-in Tool.
- ⇒ Guide the climbing enclosure with ropes.



- Immediately place the correct Spacer as support on the pawl (10.2) of the Climbing Shoe.
- In order to facilitate threading through, do not fasten the guiding brackets (10.6) until the climbing enclosure has been mounted.

Assembly

1. Insert Climbing Rails into the opened top Climbing Shoes (10a). Use the Guide-in Tool (98). (Fig. C3.06a)
2. Close the folding runners (10.3) of the top Climbing Shoe and secure, see Section "Opening and Closing the Rail Guidance Shoe" on Page 112.
3. Remove the Guide-In Tool.
4. Place the climbing enclosure with Spacer (2.1) on the climbing pawl (10.2). (Fig. C3.06)

Components

- | | |
|-------------|----------------------|
| 2.1 | Spacer LPS 52 |
| 10 | Slab Shoe-2 LPS 10 t |
| 10.2 | Climbing Pawl |
| 10.3 | Folding Runners |
| 10.6 | Guiding Bracket |
| 98 | Guide-in Tool |

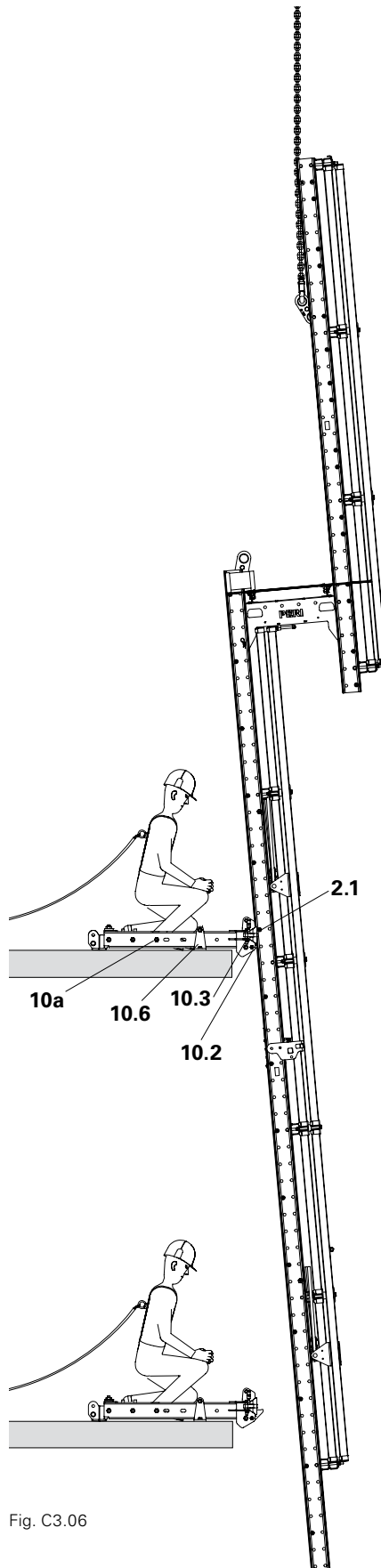

Fig. C3.06

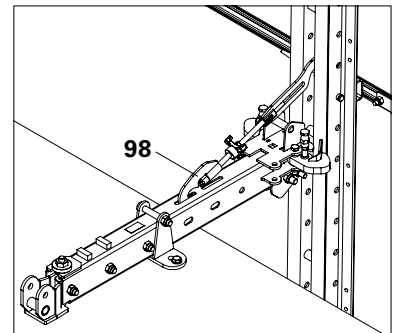

Fig. C3.06a

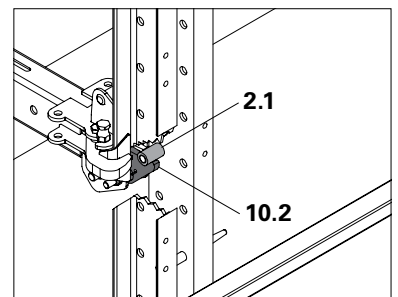

Fig. C3.06b

5. Continue to relieve the crane lifting gear and thereby insert the Climbing Rail into the bottom Climbing Shoe (10b).
6. Close the folding runners (10.3) of the bottom Climbing Shoe and secure.
7. Align climbing unit.
8. Tighten guiding brackets (10.6) of all Slab Shoes.
9. Raise climbing unit approx. 10 cm.
10. Activate the climbing pawls of the bottom Slab Shoe and deactivate the top Slab Shoe. (Fig. C3.07)
11. Completely relieve crane and release crane lifting gear from a safe position.

Components

-
- 2.1 Spacer LPS 52
 - 10 Slab Shoe-2 LPS 10 t
 - 10.2 Climbing Pawl
 - 10.3 Folding Runners
 - 10.6 Guiding Bracket
-

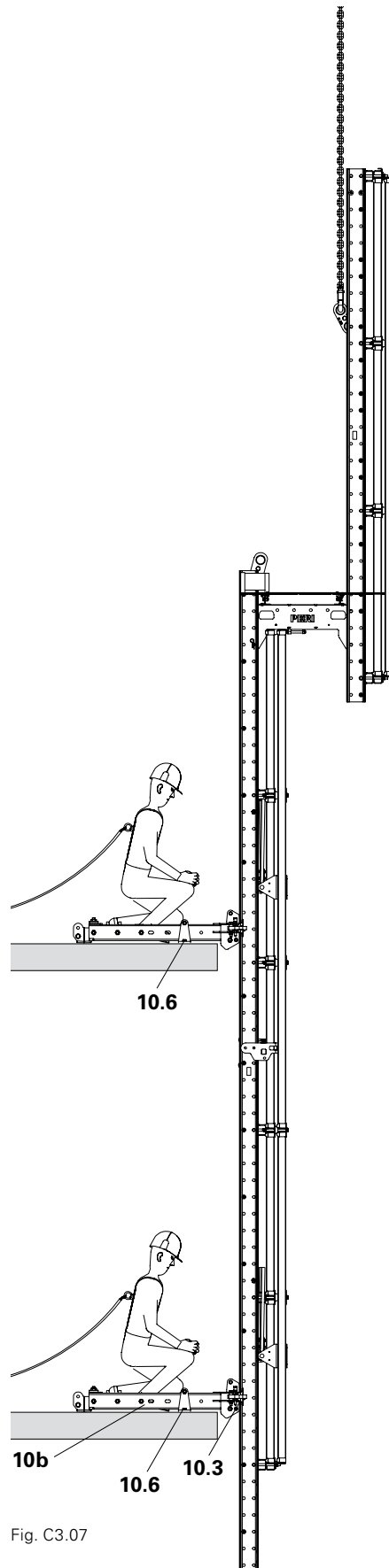

Fig. C3.07

After setting up



Warning

- Risk of falling from unsecured building edges. A fall can result in serious injury or even death.
⇒ Install guardrails.
⇒ Use personal protective equipment to prevent falling from a height (PPE).
- During assembly, components may fall to the ground and hit people below. This could lead to serious injuries or even death.
⇒ Cordon off areas of risk under the working areas.

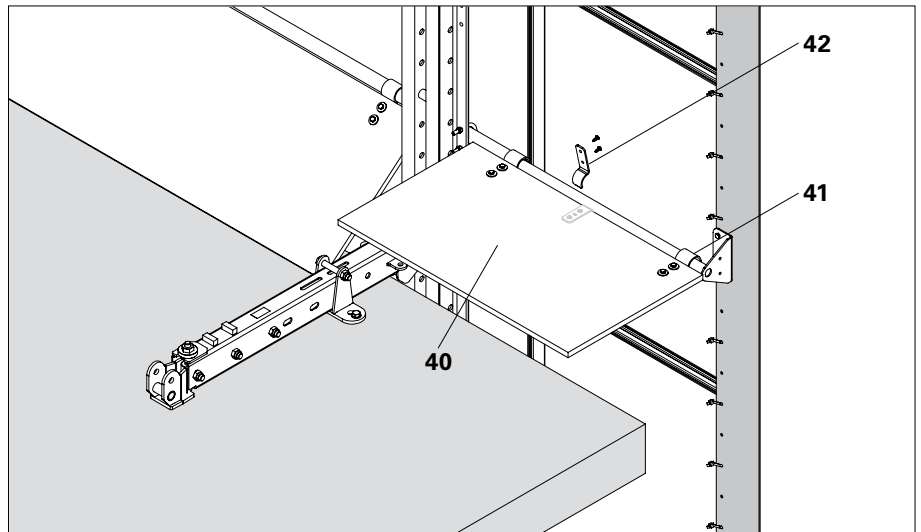

Fig. C3.08

Assembly

1. Fold down the Foldable Cover between the Climbing Rails.
2. Mount Foldable Covers (40) in the area of the Telescopic Screen.
3. For each Foldable Cover, mount one Flap Safety Plate (42) approximately in the centre using 2 SPAX Screws TX 30 8x20.

(Fig. C3.08)



Each Foldable Cover must be attached to the scaffold tube using at least 2x Flap Hinges LPS (41) and a Flap Safety Plate LPS (42)

Components

-
- | | |
|-----------|----------------------------|
| 40 | Foldable Cover |
| 41 | Flap Hinge LPS Ø 48/M10 |
| 42 | Flap Safety Plate LPS Ø 48 |
-

Closing gaps

1. Close the gap in the area of the Slab Shoe with Cover Mat LPS 60x75 (60). If necessary, fix with nails on the Cover Flap. (Fig. C3.09)
2. Close the gap in the area of the platform at the enclosure post using Cover Mat LPS 40x26 U120-140 (61.1). (Fig. C3.09a)
3. Cover any remaining gaps with suitable means. Make sure that neither the climbing procedure nor the opening of the flaps is impaired in any way. See also Section "Protection against Falling Objects" on Page 47.

Components

60 Cover Mat LPS 60 x 75 U140

61.1 Cover Mat LPS 41 x 66

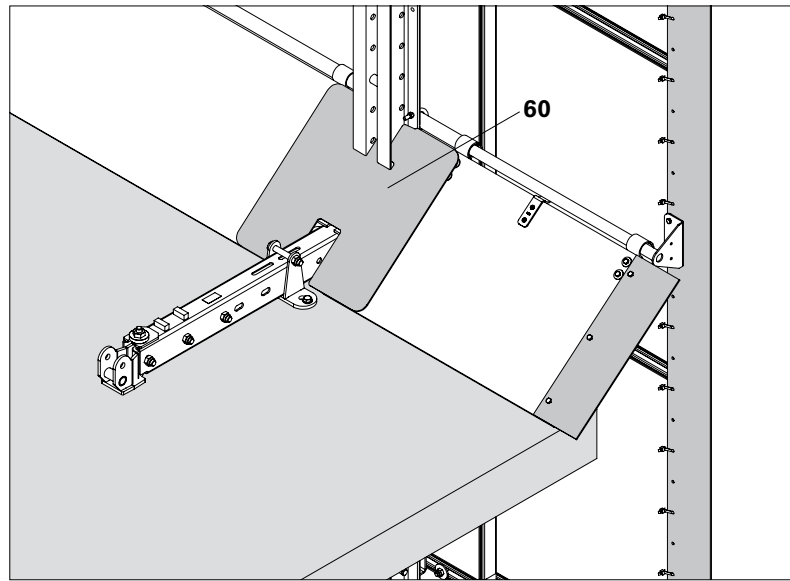

Fig. C3.06

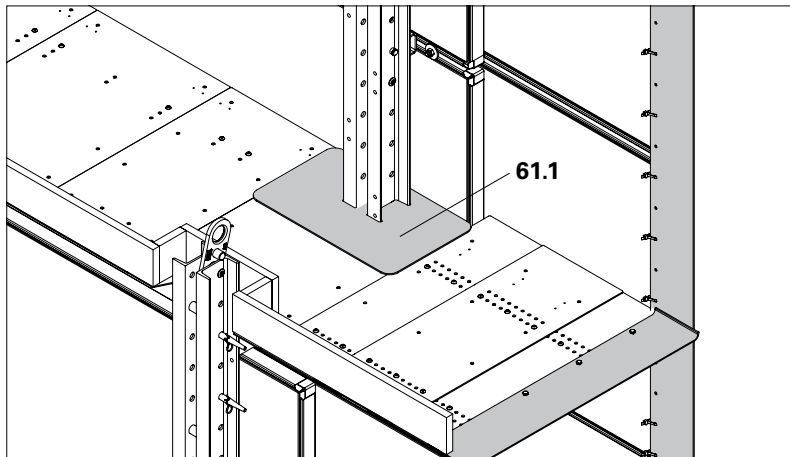

Fig. C3.06a

Troubleshooting



Warning

During assembly on the construction site, components may fall to the ground and hit people below. This could lead to serious injuries or even death.

⇒ Cordon off areas of risk under the working areas.

Problem	Cause	Measure
Folding runners cannot be closed.	– Climbing Rail is not completely in position in the Guide Shoe.	– Pull Climbing Rail with Guide-in Tool inwards.
	– Climbing rail spacing not correct.	– Detach climbing enclosure and adjust spacing of Climbing Rail.
	– Slab Shoe spacing is not correct.	– Slightly loosen the fixing of the Guide Shoes, close the folding runners and tighten them using component tolerances. Alternatively: – Mount new anchoring with tie rods and Wingnut Counterplates through the slab.
Climbing unit does not lie on the planned Spacer on both sides.	– Climbing Rail rests on a Slab Shoe that is positioned below. – Slab distance is approx. a multiple of 50 cm.	– Raise the climbing unit by approx. 6 cm using the crane. Deactivate the pawls of all Slab Shoes positioned below. Position climbing unit with the planned Spacer on the pawl of the top Slab Shoe.

Fixing the Leading Anchor

With the Slab Anchor Template-2 LPS (16), the Leading Anchor (13) is fixed in position during concreting.
Variable length a = up to 1000 mm, see following pages.



- The stop on the support plate creates an impression in the concrete.
- For transportation, completely insert the Slab Anchor Template, fold up and then secure with Fitting Pins!

Assembly

1. Attach Slab Anchor Template (16) to the enclosure post (4) by means of Fitting Pins (81) and Cotter Pins (86).
2. Fix Leading Anchor (13) to Support M24 (16.7).
3. Swivel Slab Anchor Template downwards.
4. Adjust length a :
 - Release wing screws (16.8) on the clamping piece.
 - Move clamping piece to required position.
 - Place support plate (16.1) on stopend formwork and fix using nails or screws (holes \varnothing 5 mm).
 - Tighten wing screws.
5. Adjust Slab Anchor Template on the Height Adjustment DW 15 (16.4) to the correct height using the spirit level.

(Fig. D1.01 + D1.02)

Components

4	Enclosure Post
13	Leading Anchor
16	Slab Anchor Template-2 LPS
16.1	Support Plate
16.4	Height Adjustment
16.7	Support M24
16.8	Wing Screw
16.9	Handgrip
81	Fitting Pin \varnothing 21x120
86	Cotter Pin 4/1

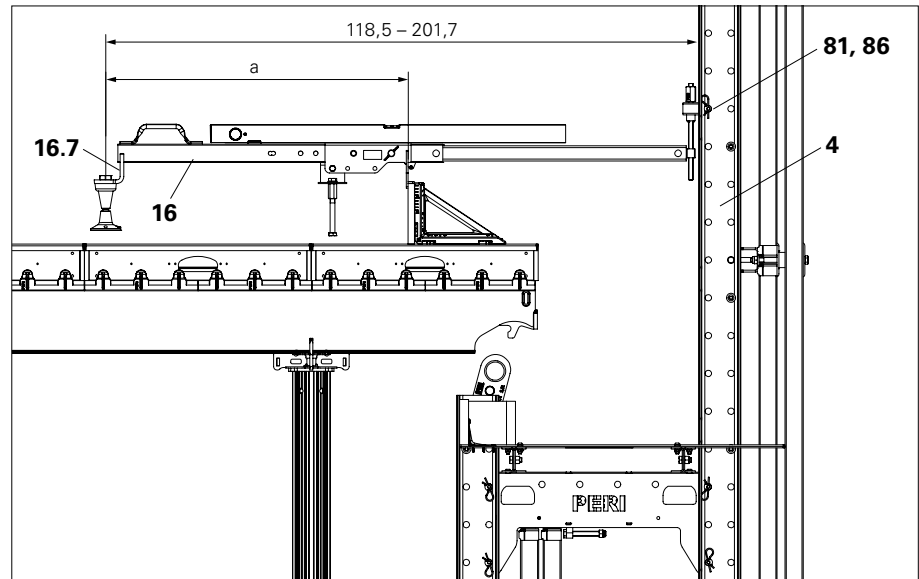

Fig. D1.01

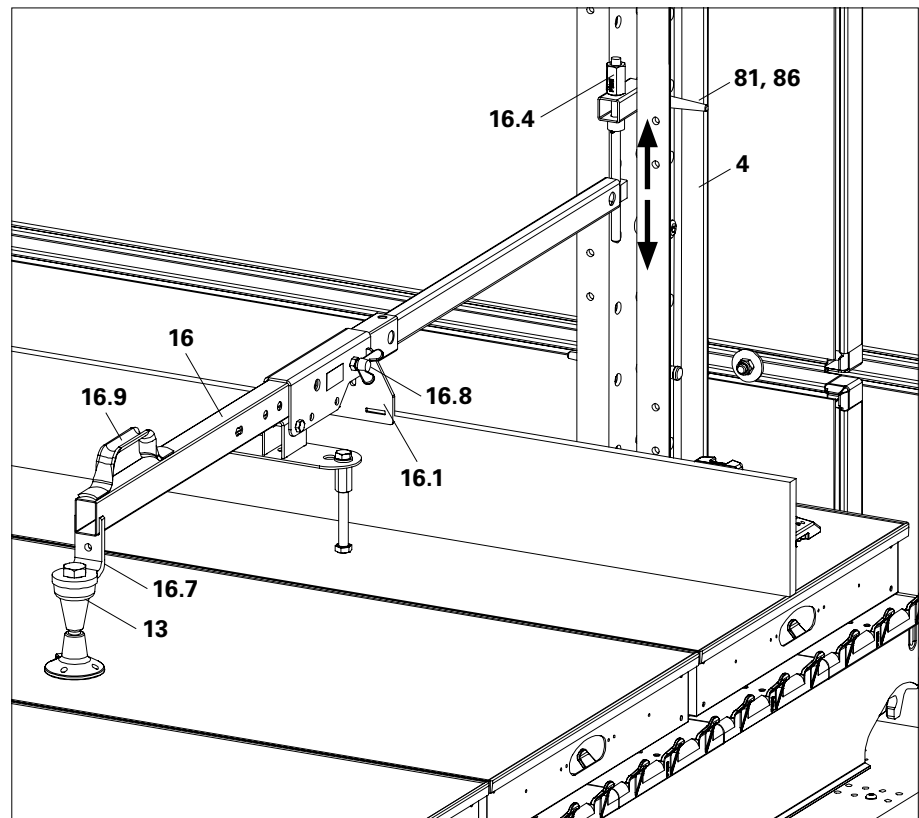

Fig. D1.02

Fixing with Embedded Bolts



If bolts and nuts are used to tighten the guiding bracket:

1. Attach two long Nuts M16x50 (17) 20 mm to Bolts, e.g. M16x120 (15).
 2. Secure with other Bolts M16x30 (18) and Washers (19) in the bracket for the Anchor Bolt (16.6).
 3. Tighten Bolts M16x120.
- (Fig. D1.03)

After concrete has hardened

1. Release Slab Anchor Plate from Leading Anchor and front support.
2. Completely insert the Slab Anchor Plate.
3. Swivel up the Slab Anchor Template.
4. Pass Fitting Pin through Handgrip (16.9) and enclosure post (4). Secure Fitting Pins with Cotter Pins.
5. Protect the thread of the long Nut M16x50 from dirt by means of a Bolt M16.
6. Protect the thread of the embedded Climbing Anchor from dirt by means of Bolt M24 or Anchor Positioning Stud M24.

(Fig. D1.04)

Components

15	Bolt ISO 4014-M16x120-8.8
16	Slab Anchor Template-2 LPS
16.9	Handgrip
17	Nut M16x50
18	Bolt M16x30
19	Washer
81	Fitting Pin \varnothing 21x120
86	Cotter Pin 4/1

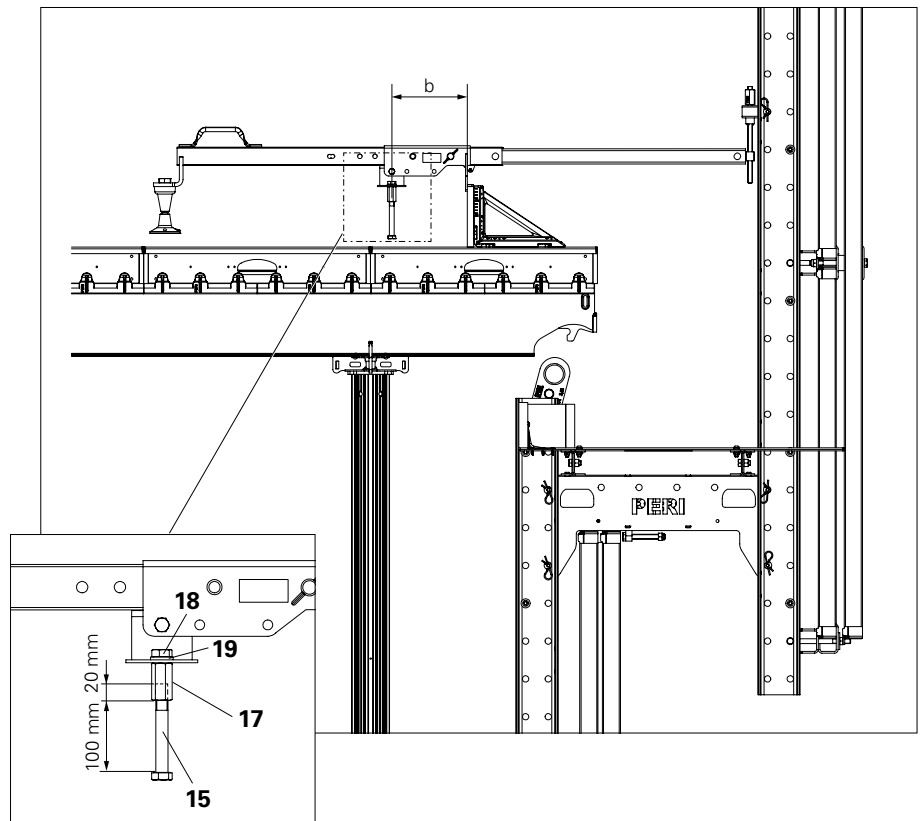

Fig. D1.03

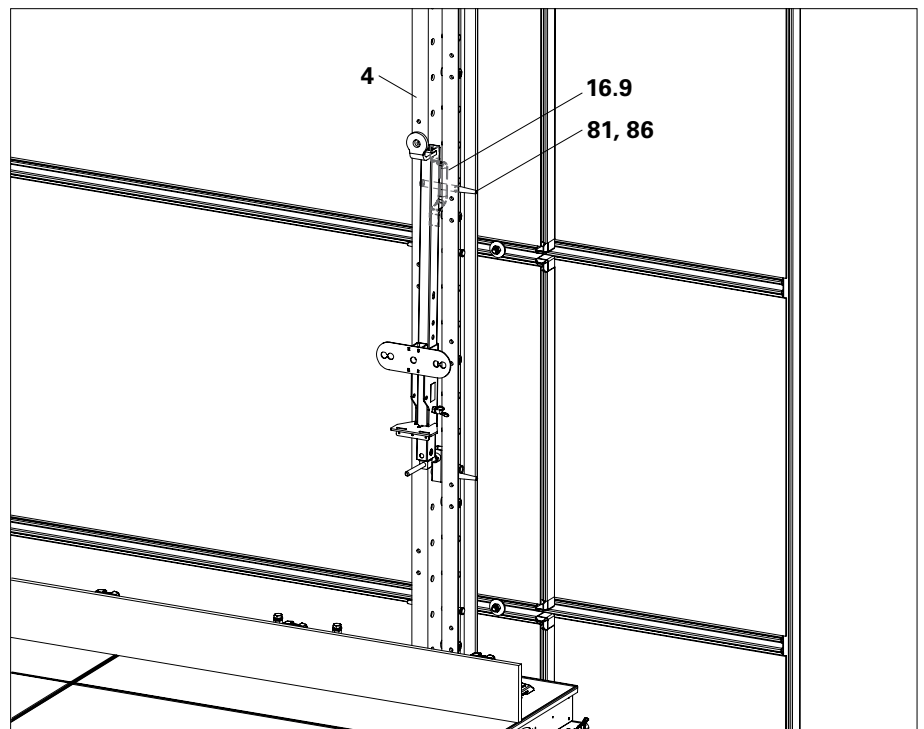

Fig. D1.04

Use of Slab Anchor Template for straight screens (Version 1)

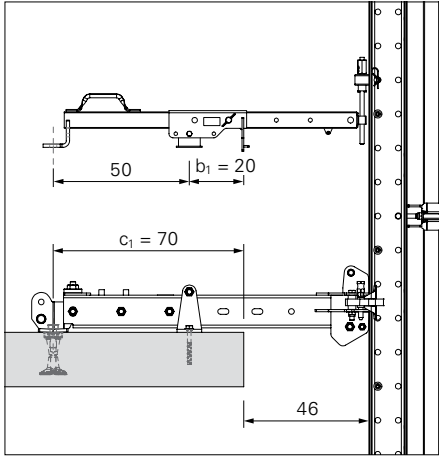

Fig. D1.04

Slab Anchor Template $c_1 = 700$ mm
Support distance $b_1 = 200$ mm
Version 1 - Standard Position.

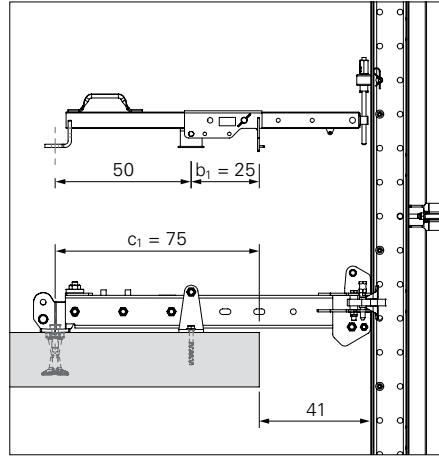

Fig. D1.05

Slab Anchor Template $c_1 = 750$ mm
Support distance $b_1 = 250$ mm
Version 1 - Special Position 1

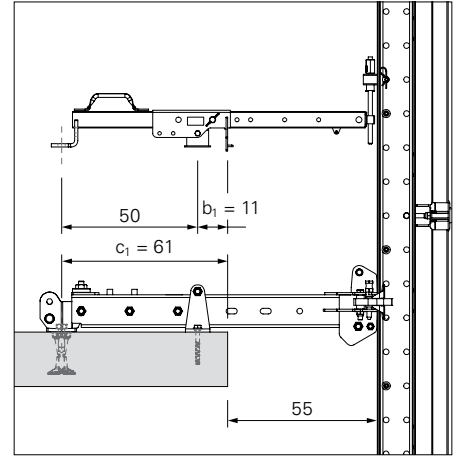

Fig. D1.06

Slab Anchor Template $c_1 = 610$ mm
Support distance $b_1 = 110$ mm
Version 2 - Special Position 2

Use of Slab Anchor Template for screens with platform (Version 2)

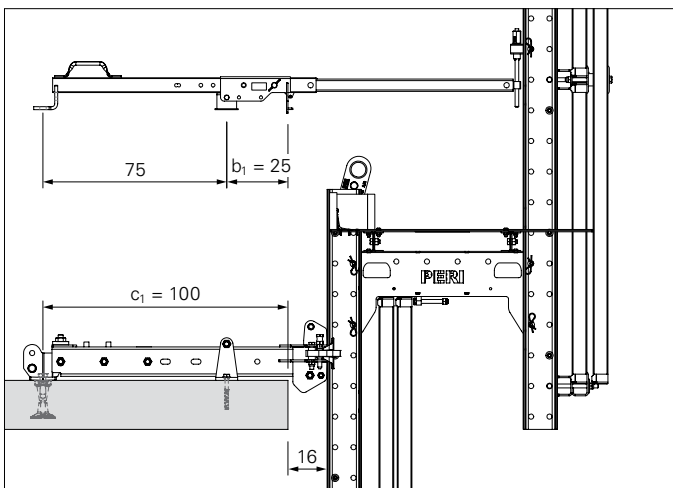

Fig. D1.07

Slab Anchor Template $c_1 = 1000$ mm
Support distance $b_1 = 250$ mm
Version 2 - Standard Position.

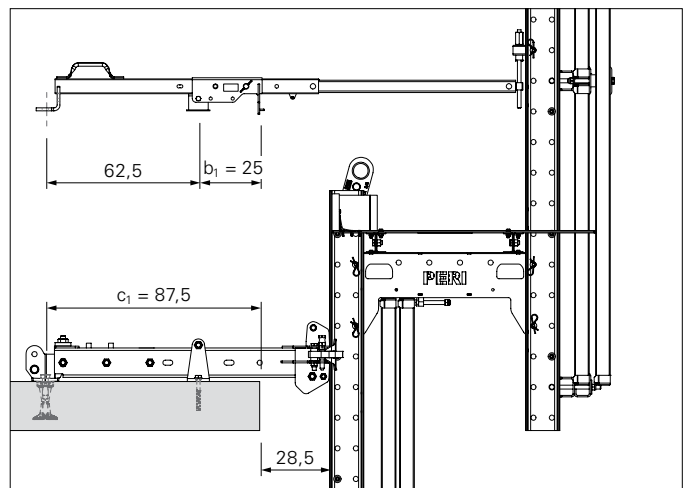

Fig. D1.08

Slab Anchor Template $c_1 = 875$ mm
Support distance $b_1 = 250$ mm
Version 2 - Special Position

Fixing the slab anchor in the reinforcement



In order to prevent the climbing anchor from moving, PERI recommends fixing the anchor to the top reinforcement of the slab.

1. Create an opening in the reinforcement for the Threaded Anchor Plate (13.2). If necessary, move colliding reinforcement bars. For mesh reinforcement, cut rod (96) and replace it with reinforcement bars of the same diameter.
2. Insert two pairs of reinforcement bars crosswise in the top (96a) and bottom (96b) positions of the top reinforcement.
3. Fold down Slab Anchor Template (16) and install Climbing Cone (13.5). Align Slab Anchor Template and secure.
4. Push the 4 reinforcement bars (96a + 96b) all the way up to the Climbing Cone (13) so that they touch it on each side. Attach reinforcement bars to the slab reinforcement by means of wires.
5. Fix embedded front anchors (15) with one pair of reinforcement bars (96c) to the top reinforcement using wires. (Fig. D1.09 + D1.09a)

Components

13.2	Threaded Anchor Plate DW 20
13.5	Climbing Cone-2 M24/DW 15
15	Bolt ISO 4014-M16x120-8.8
16	Slab Anchor Template-2 LPS
96	Reinforcement

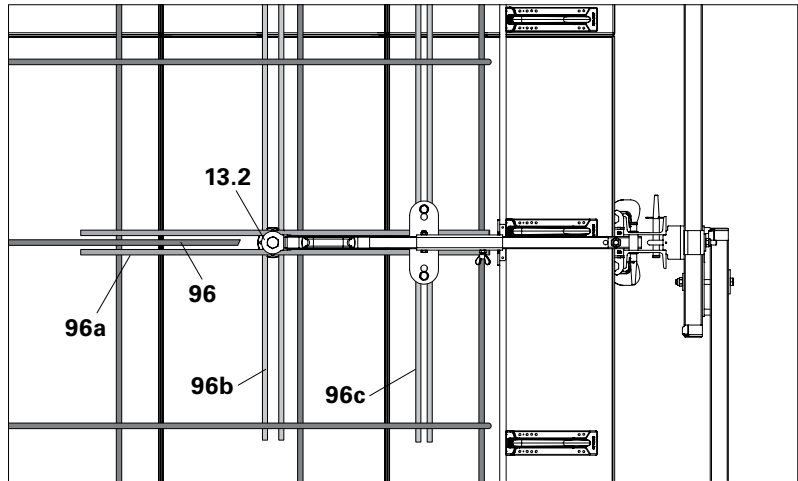

Fig. D1.09

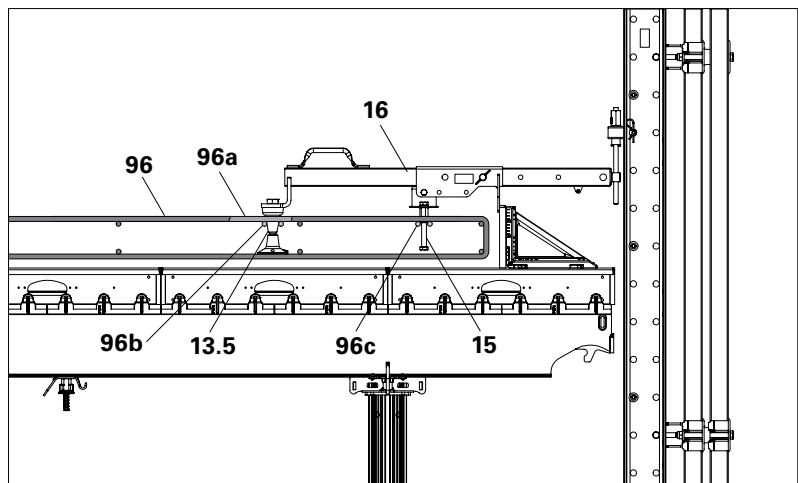

Fig. D1.09a

Assembly of Slab Shoe LPS



Warning

If not correctly assembled, the Slab Shoe can tip over the edge of the slab, fall to the ground and hit people below. This could lead to serious injuries or even death.

- ⇒ Cordon off areas of risk under the working areas.
- ⇒ Loosely screw Slab Shoe onto the anchoring (71), then position over the edge of the slab.

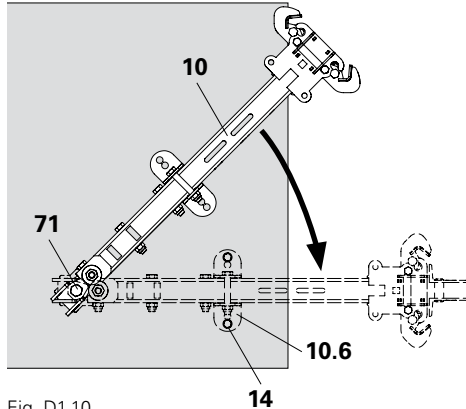

Fig. D1.10



Assembly of the Slab Shoe is usually carried out with protection provided by the climbing enclosure. If this is not possible in exceptional cases or the gap to the enclosure is too large, use personal protective equipment to prevent falls.

To ensure that the Slab Shoe does not fall off the slab edge, in particular when there is a large cantilever (Version 1), it is first secured against lifting with the Bolt M24 (71).

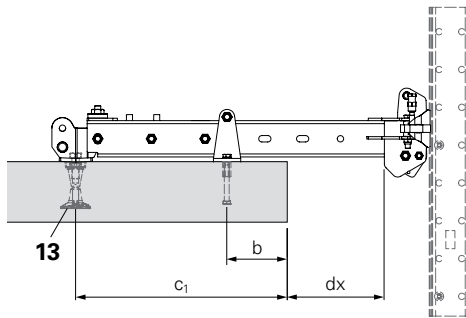

Fig. D1.10a

1. Place Slab Shoe (10) on the slab at an angle.
2. Loosely screw onto anchoring (13) using Hex. Bolt ISO 4014 M24x70-10.9 (71).
3. Turn Slab Shoe into the correct position and lower it.
4. Tighten Bolt M24x70 (71).
5. Fix guiding bracket (10.6) to the floor slab with anchor bolts (14) according to plan. Alternatively, secure with suitable heavy-duty dowels or on embedded bolts and long nuts.

(Fig. D1.10 + D1.10a)



Have all fixings been correctly tightened?



According to plan, there is a gap between the slab edge and the stop plate of the Slab Shoe:

Standard for Version 1
(for straight screens):

$c_1 = 700 \text{ mm}$,
 $b = 200 \pm 10 \text{ mm}$,
 $dx = 320 \text{ mm}$.

Standard for Version 2
(screen with working platform):

$c_1 = 1000 \text{ mm}$,
 $b = 250 \pm 10 \text{ mm}$,
 $dx = 10 \text{ mm}$.

Components

- 10** Slab Shoe-2 LPS
- 10.6** Guide Bracket-2 LPS
- 13** Anchoring M24
- 14** PERI Anchor Bolt 14/20x130
- 71** Bolt ISO 4014 M24x70-10.9

Dismantling Slab Shoe LPS

Warning

- There is a risk of falling on unsecured slab edges. A fall can result in serious injury or even death!
 - ⇒ Mount guardrails before climbing.
 - ⇒ Use personal protective equipment to prevent falls.
- If not correctly assembled, the Slab Shoe can tip over the edge of the slab, fall to the ground and hit people below. This could lead to serious injuries or even death.
 - ⇒ Cordon off areas of risk under the working areas.
 - ⇒ First loosen the anchoring (71) slightly and turn the Slab Shoe to a secure position.



If possible, install guardrails on the slab edge before dismantling the Slab Shoe. Supplement Toe Board after dismantling the Slab Shoe.

To ensure that the Slab Shoe does not fall off the slab edge, in particular when there is a large cantilever, it is first turned to a secure position and then unscrewed.

1. Loosen Anchor Bolt (14) or dowel in guiding bracket (10.6) and remove.
2. Loosen Bolt ISO 4014 M24x70-10.9 (71) approx. 15 mm, but do not remove.
3. Lift Slab Shoe LPS (10) and turn it inwards to a secure position.
4. Remove Bolt M24x70 (71).
(Fig. D1.10 + D1.10a)

Components

10	Slab Shoe-2 LPS
10.6	Guide Bracket-2 LPS
13	Anchoring M24
14	PERI Anchor Bolt 14/20x130
71	Bolt ISO 4014 M24x70-10.9

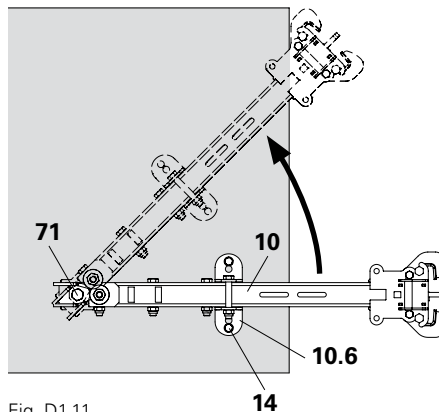

Fig. D1.11

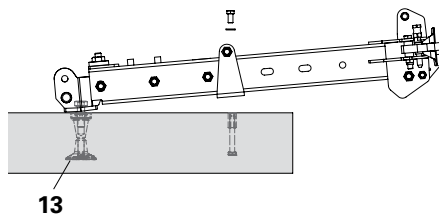

Fig. D1.11a

Removing the Anchoring



Warning

There is a risk of falling from unsecured slab edges. A fall can result in serious injury or even death!

- ⇒ Mount guardrails before climbing.
- ⇒ Use personal protective equipment to prevent falls.



- Work to be carried out with site personnel protected by guardrails that follow the climbing protection panel.
- For fixing the concrete cones, observe the separate Instructions for Use!

Anchoring M24 Version 1

Screw-On Cone M24/DW 20 (13.1) partially re-usable.

1. Release Screw-On Cone with socket wrench SW 36 and remove.
 2. Close remaining hole with suitable KK Concrete Cone (13.9) and adhesive.
- (Fig. D1.12a)

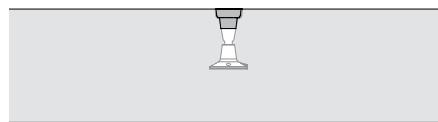
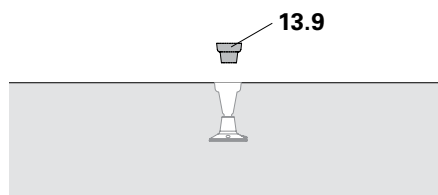
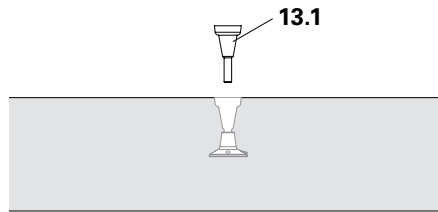

Fig. D1.12a

Anchoring M24 Version 2

Anchor Sleeve M24 (13.3) not re-usable.

1. Anchor Sleeve M24 remains in the concrete.
 2. Close the Spacer for Anchor Sleeve M24 with Plug PP Ø 26 mm (13.10).
- (Fig. D1.12b)

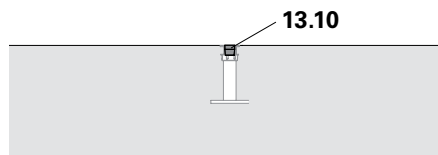
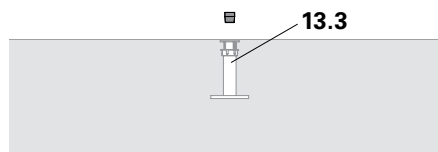

Fig. D1.12b

Components

- 13.1** Screw-On Cone-2 M24/DW 20
- 13.3** Anchor Sleeve M24
- 13.9** KK Concrete Cone M24
- 13.10** Plug PP Ø 26 mm

Anchoring M24 Version 3

Climbing Cone-2 M24/DW 15 (13.5)
partially re-usable.

1. Release Climbing Cone by means of socket wrench SW 36 and remove.
2. Close remaining hole with suitable KK Concrete Cone (13.9) and adhesive.
(Fig. D1.12c)



Warning

During dismantling, anchoring components may fall to the ground and hit people below. This could lead to serious injuries or even death.

⇒ Cordon off areas of risk under the working areas.

⇒ In order to prevent personnel falling out of the building, use a guardrail underneath with a dense mesh, e.g. PROKIT.

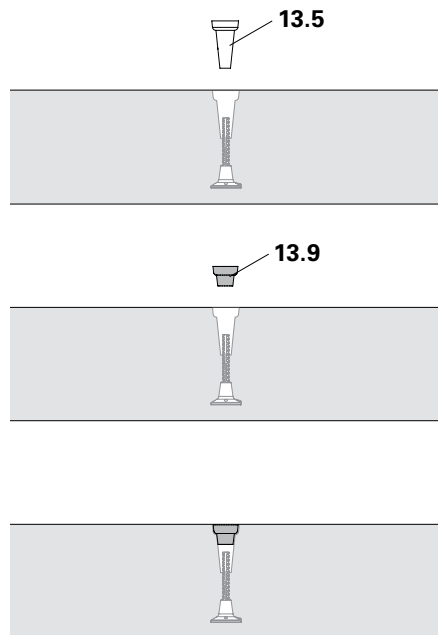

Fig. D1.12c

Anchoring M24 Version 4

Climbing Cone-2 M24/DW 15
completely re-usable.

1. Loosen Climbing Cone (13.5) using a socket wrench SW36 and screw out approx. 1 cm.
2. Hammer cone down so that the Threaded Anchor Plate DW 15 (13.7) is loosened.
3. Now completely remove the Cone. Remove the Threaded Anchor Plate together with Tie Rod DW 15 from below using a secured mobile scaffold.
4. Close remaining hole with suitable KK Concrete Cone (13.9) and matching adhesive.
(Fig. D1.12d)

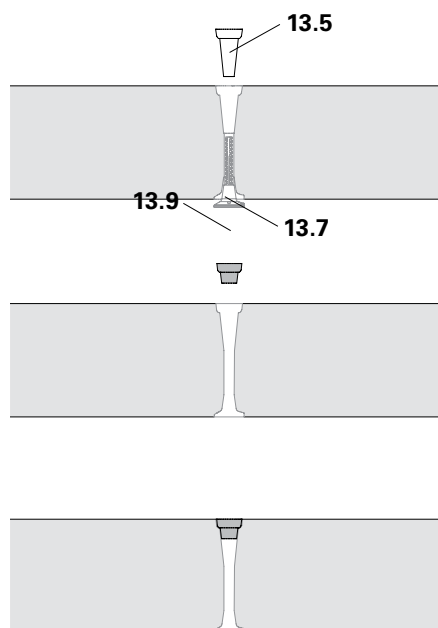

Fig. D1.12d

Components

- | | |
|-------------|-------------------------------------|
| 13.5 | Climbing Cone-2 M24/DW 15 |
| 13.7 | Threaded Anchor Plate DW 15 Ø 80 mm |
| 13.9 | KK Concrete Cone M24 |

Opening and Closing the Rail Guidance

The rail guidance (12) is the front part of the Slab Shoe (10) or the Rail Guidance Shoe LPS.

The climbing pawl (10.2) snaps into the Spacer LPS 52 of the Climbing Rail. The Threaded Bolts LPS DW 15 (10.1) hold the guiding skids (10.3) in a closed position. (Fig. D2.01 + D2.01a)

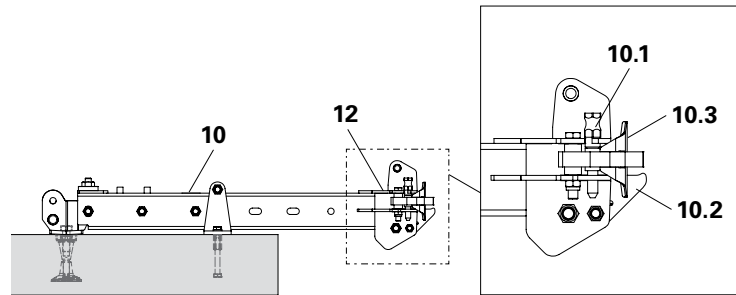

Fig. D2.01

Fig. D2.01a

Opening the rail guidance:

1. Screw out Threaded Bolt LPS DW 15 (10.1).
2. Fold open guiding skid (10.3). (Fig. D2.02a)
3. Proceed in the same way with the other guiding skid. (Fig. D2.02b)



Opening the guiding skids facilitates inserting the Climbing Rail during climbing and allows inserting the Climbing Rail during initial assembly.

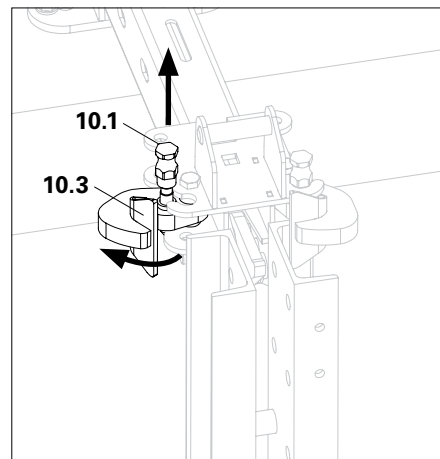

Fig. D2.02a

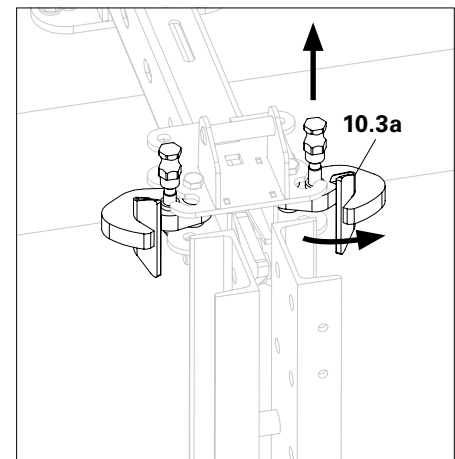

Fig. D2.02b

Closing the rail guidance:

1. Fold guiding skid (10.3) forwards.
2. Screw in Threaded Bolt LPS DW 15 (10.1) again.
3. Proceed in the same way with the other guiding skid. (Not shown)



Have both Threaded Bolts been screwed in completely?

Components

-
- 10** Slab Anchor Shoe-2 LPS
 - 10.1** Threaded Bolt LPS DW 15-2 LPS
 - 10.2** Climbing Pawl
 - 10.3** Folding Runners
 - 10.4** Hole for Climbing Pawl
 - 13.7** Threaded Anchor Plate DW 15 Ø 80 mm
 - 13.9** KK Concrete Cone M24
-

Activating and Deactivating the Climbing Pawl

Deactivating the climbing pawl



Warning

Hands can get caught between the Climbing Rail and Slab Shoe and become trapped. This can cause serious injury.

- ⇒ The climbing pawl is only deactivated when the climbing unit has stopped moving.
- ⇒ Do not reach into the Climbing Rail whilst climbing!

1. Ensure that the climbing unit is stationary.
 2. Reach into the Rail Guidance Shoe from below and turn climbing pawl (10.2) upwards.
 3. Insert Wire Nail 100 x 4.0 through the hole (10.4) in the climbing pawl 10.2 in order to block it.
- The climbing pawl is deactivated and, thus, non-operational.



Can the wire nail slip out?



In this position, no vertical forces from the Climbing Rail can be transferred via this particular shoe.

Activating the climbing pawl



Warning

Hands can get caught between the Climbing Rail and Slab Shoe and become trapped. This can cause serious injury.

- ⇒ The climbing pawl is only operational when the climbing unit has stopped moving.
- ⇒ Do not reach into the Climbing Rail whilst climbing!

1. Ensure that the climbing unit is stationary.
 2. Pull the previously inserted Wire Nail 100 x 4.0 out of the climbing pawl.
- The climbing pawl jumps into its working position.
- The climbing pawl is activated and, thus, operational.



Can the climbing pawl move freely?



- This position serves the purpose of transferring vertical forces from the Climbing Rail during working operations and climbing.
- For storey heights that are dividable by approx. 50 cm, only activate the pawls on the Slab Shoes that serve as the planned vertical support. Deactivate all other Slab Shoes.

Components

10.2 Climbing Pawl

10.4 Hole for Climbing Pawl

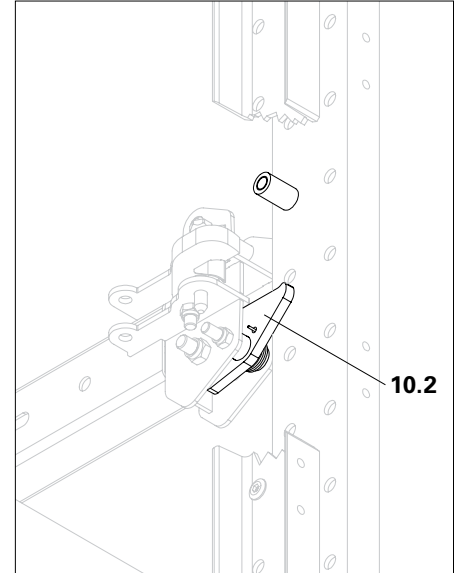

Fig. D2.03a

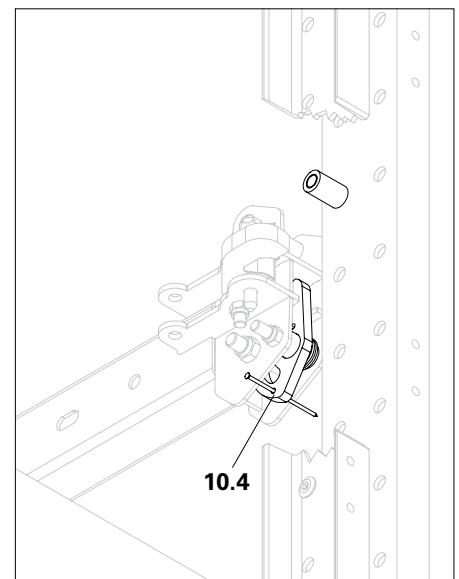

Fig. D2.03b

Height Adjustment of the Slab Shoe

Adjust the height of the Slab Shoes, enabling the mesh enclosure to be vertically aligned.



Slab Shoes are difficult to adjust when loaded.

⇒ Ensure Slab Shoes are unloaded before adjusting the height.

⇒ Ensure that the climbing unit is stationary.

1. For lifting the Slab Shoe, turn the Adjusting Bolt SW 36 (10.7) in an anti-clockwise direction; for lowering, turn in a clockwise direction.
2. Use a straight board with a spirit level in order to align the pair of shoes and thus the mesh enclosure of a climbing unit.

Standard pawl measurement above the slab = 83 mm.

For anchor distance $a = 700$ mm (standard position for Version 1), the adjustment range for the pawl position is $71 \dots 95$ mm = 83 ± 12 mm. (Fig. D2.04a + D2.04b)

For anchor distance $a = 1000$ mm (standard position for Version 2), the adjustment range for the pawl position is $77 \dots 89$ mm = 83 ± 6 mm. (Fig. D2.04c + D2.04d)

Components

10.7 Adjusting Bolt SW 36

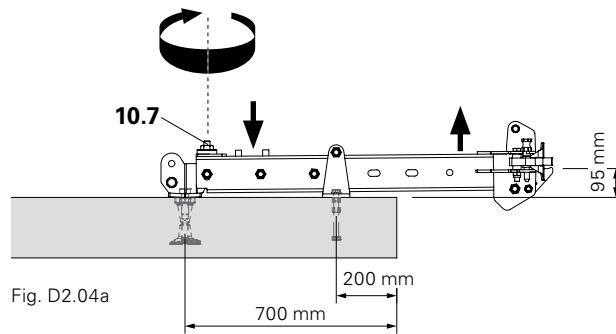

Fig. D2.04a

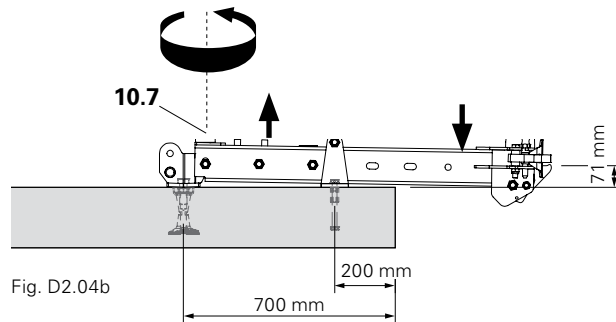

Fig. D2.04b

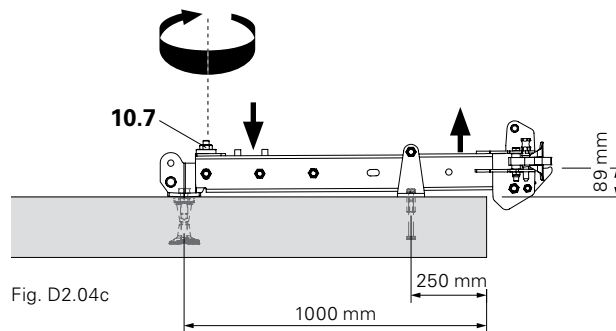

Fig. D2.04c

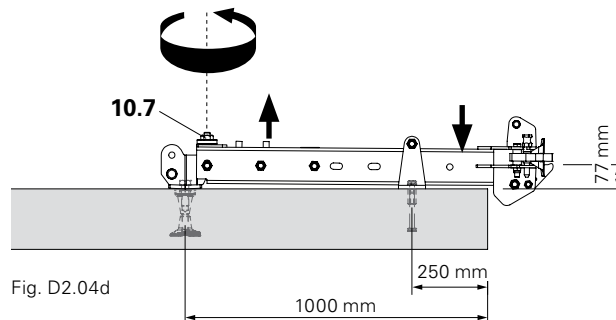

Fig. D2.04d

Vertical Bracing



- Mount bracing connections (8) in the outer row of holes on the Climbing Rail (2).
- The web plates of the Climbing Rails must engage the notches (8.6) of the bracing connections.
- The anchoring points must point towards each other and in the direction of the Bracing Chains.
- Foldable Covers must be able to be folded up and secured.

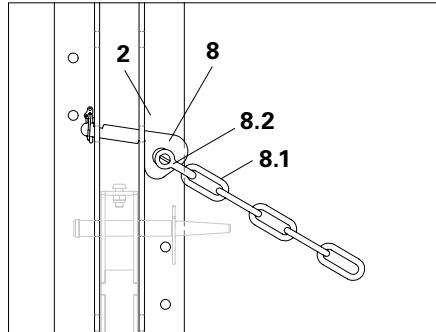

Fig. D3.01a

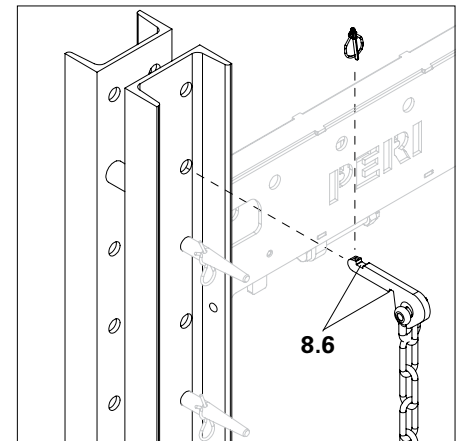

Fig. D3.02

Assembly:

1. Mount the Bracing Chain (8.1) with Shackle (8.2) to the bracing connection (8).
2. From above, insert bracing connection with mounted chain into the first free hole of the Climbing Rail (2). Secure bracing connection with linch pin (8.3).
3. Mount additional bracing connection above the Slab Shoe and secure with linch pin.
4. Attach Bracing Chain with Turnbuckle (8.4) to the bracing connection. Secure chain overhang to the Bracing Chain by means of a snap hook (8.5).
5. Pre-tension Bracing Chain with Turnbuckle:
 - Oiled Turnbuckle: hand-tightened.
 - Non-oiled Turnbuckle: hand-tightened plus one complete turn (360°).

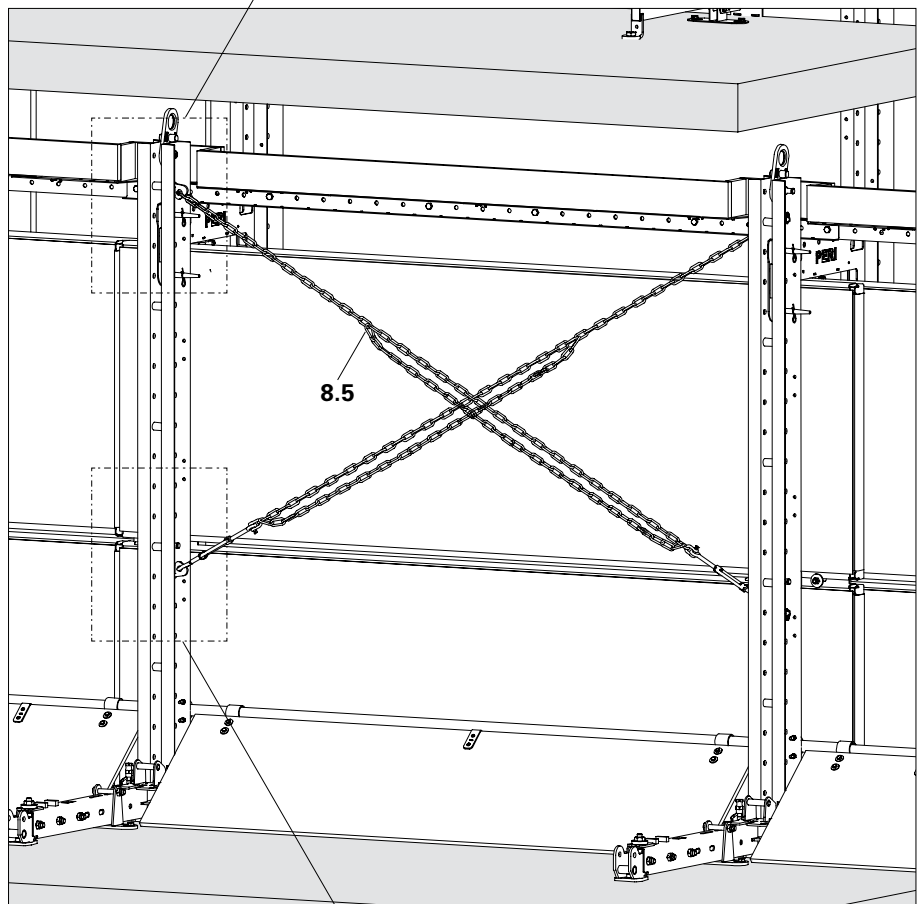

Fig. D3.01

Components

2	Climbing Rail-2 LPS
8	Bracing Connector LPS
8.1	Bracing Chain LPS 5.0 m

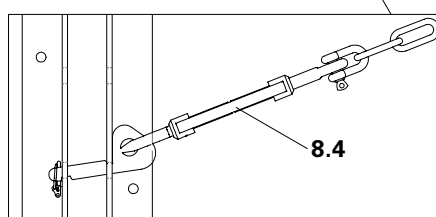

Fig. D3.01b

Safety Instructions



Warning

- There is a risk of falling from unsecured slab edges.
- As a result of the moving procedure, leading edges are formed between the platforms.

A fall can result in serious injury or even death!

- ⇒ Mount guardrails before climbing.
- ⇒ Areas of risk are to be cordoned off.
- ⇒ Use personal protective equipment to prevent falls.



Warning

Parts of the body can get caught between the Climbing Rail and Slab Shoe and become trapped. This can cause serious injury.

- ⇒ Do not take hold of anything between the Rail Guidance Shoes and Climbing Rails while the climbing enclosure is moving.



- The load-bearing capacity of the structural elements, which carry the load-transferring Slab Shoes, must be ensured!
- Do not transport persons, building materials or tools when moving with the crane. These could fall off and cause serious injury or even death.
- Material or other components must not protrude beyond the slab edge. This could hinder climbing or fall off.
- In the event of a malfunction, the climbing unit is to be set down in the next possible position and an authorised person is to be informed immediately!
- When climbing by crane, always provide a safe possibility to attach and detach crane lifting gear. Additional double crane slings that remain on the climbing enclosure may be necessary until they can be safely dismantled.

Preparations

1. Assemble the top Slab Shoes (10a) on the next floor slab. Open foldable skids on top Slab Shoe (10a), deactivate climbing pawl.
2. Adjust the height of the top Slab Shoe so that the climbing enclosure is subsequently aligned.
3. Activate climbing pawls on the middle Slab Shoe (10b). The load is carried on the bottom Slab Shoe (10c).
4. Remove temporary connections between the climbing units.
5. Dismantle formwork in the area of the slab edge.
6. Mount trailing guardrails (99).
7. Fold up Foldable Covers (40) and secure by sliding laterally behind the Climbing Rail.
8. From a safe position, attach crane lifting gear to Crane Eye BR 2.5 t. See Section "Connection Point for Crane" on Page 40.
9. Leave climbing enclosure and area of risk.

(Fig. D4.01 + D4.02)

For operating of the Slab Shoes, see Section "Assembly of the Slab Shoe LPS" on Page 108 as well as Section "Activating and Deactivating the Climbing Pawl" on Page 113.

Components

2	Climbing Rail-2 LPS
10	Slab Shoe-2 LPS
40	Foldable Cover
99	Guardrail, e.g. PROKIT

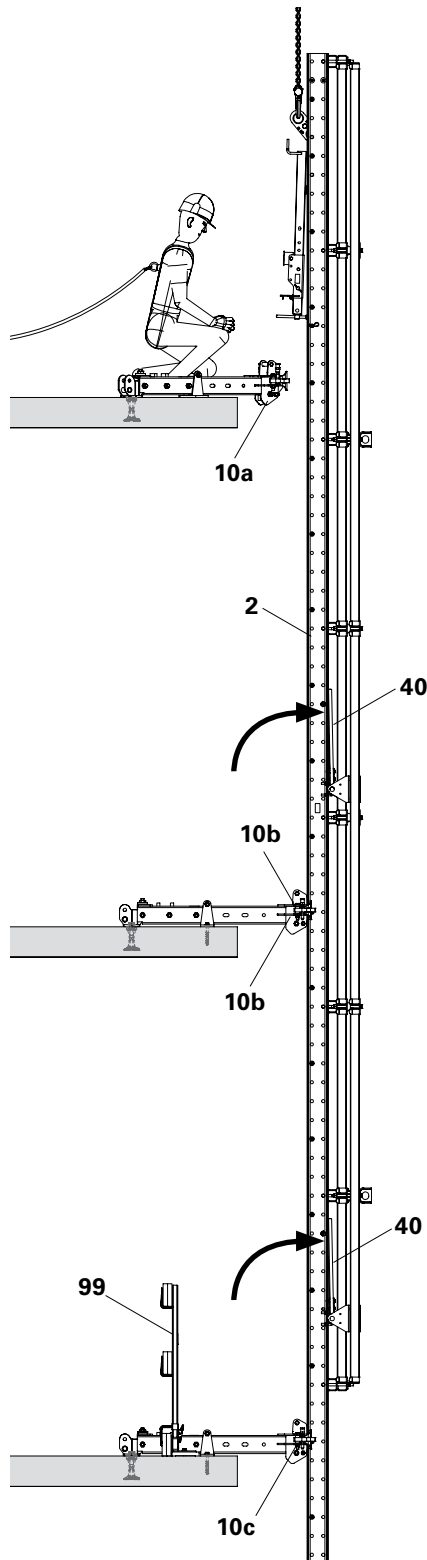

Fig. D4.01

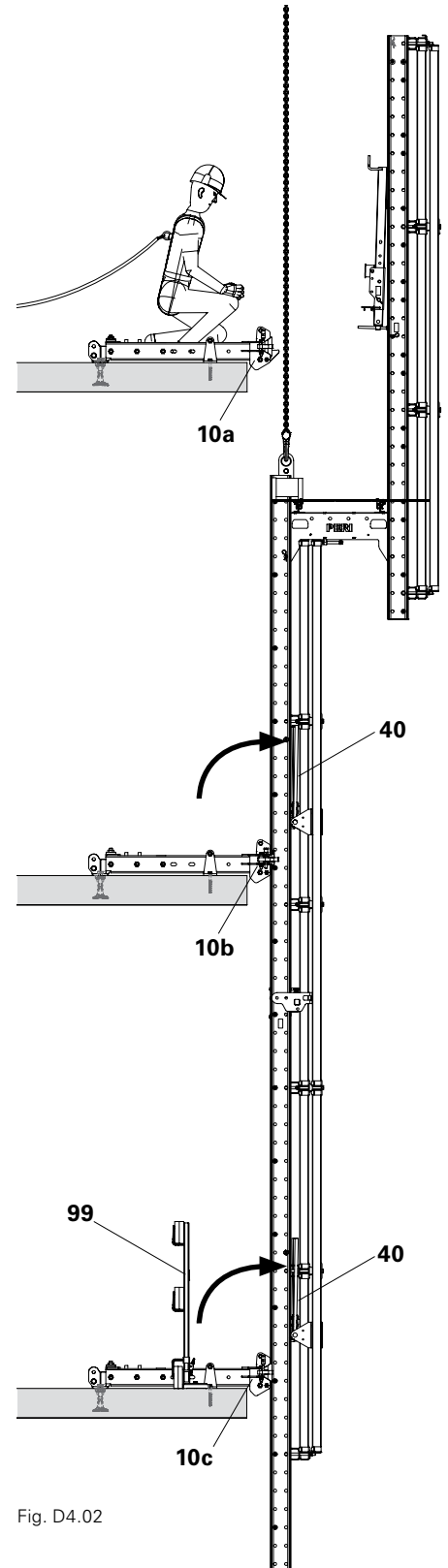

Fig. D4.02

Moving Procedure

Version 1

1. Fold the guiding skids of the Slab Shoe (10a) into the Climbing Rail (2) and close. Climbing pawl remains deactivated. (This step may have already been done during preparations between Steps 1 and 2).

Version 2

1. Raise the climbing unit to the top Climbing Shoes (10a) using the crane.
2. Insert Climbing Rail (2) into the top Climbing Shoes (10a) using the Guide-In Tool (98).
3. Close the guiding skids of the top Slab Shoe. Climbing pawl remains deactivated. (Fig. D4.03a)

Version 1 + 2

1. If necessary, deactivate pawls of the bottom Slab Shoe (10c).
2. Raise climbing unit up to the planned end position until the climbing pawls of the middle Slab Shoe (10b) engage.
3. Lower climbing unit until the Spacers are fully load-bearing on the climbing pawls of the middle Slab Shoe (10b). (Fig. D4.03 + D4.03a)

For operating the Slab Shoes, see Section "Opening and Closing the Rail Guidance Shoe" on Page 112 as well as Section "Activating and Deactivating the Climbing Pawl" on Page 113.

Components

2	Climbing Rail-2 LPS
10	Slab Shoe-2 LPS
98	Guide-in Tool

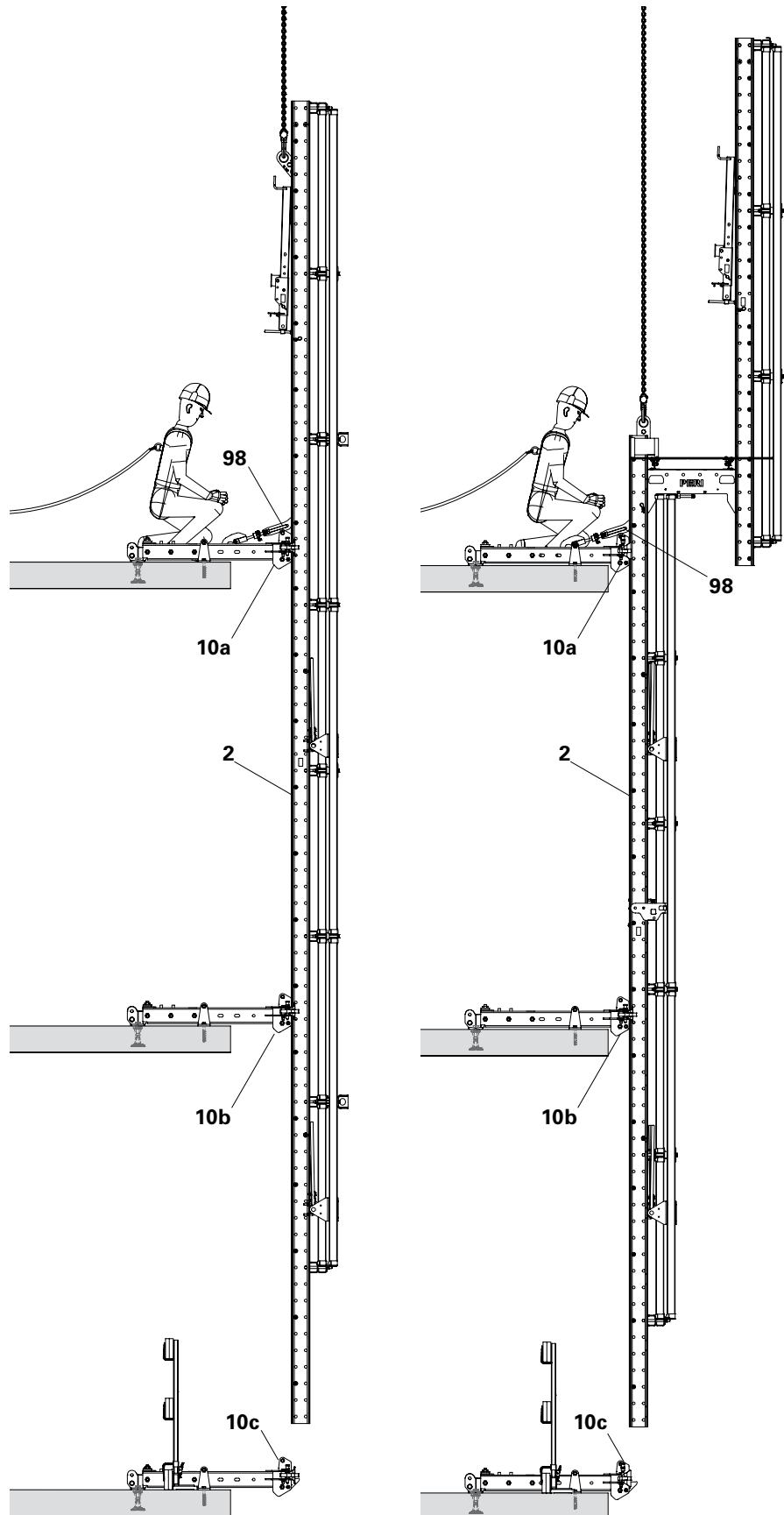

Fig. D4.03

Fig. D4.03a

If climbed too far

1. Lift climbing unit with crane by approx. 6 cm. (Fig. D4.04)
2. Deactivate all pawls of the Slab Shoe of this climbing unit. See Section "Activating and Deactivating the Climbing Pawl" on Page 113. (Fig. D4.04a)
3. Lower climbing unit until the correct Spacer is approx. 10 cm above the pawl of the load-bearing Slab Shoe (10a).
4. Activate pawl of top Slab Shoe (10a).
5. Position climbing unit on Spacer.

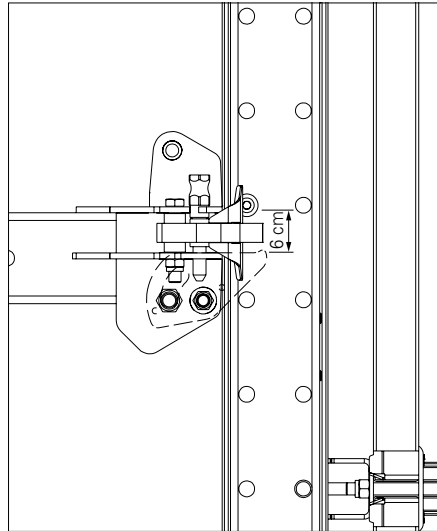

Fig. D4.04

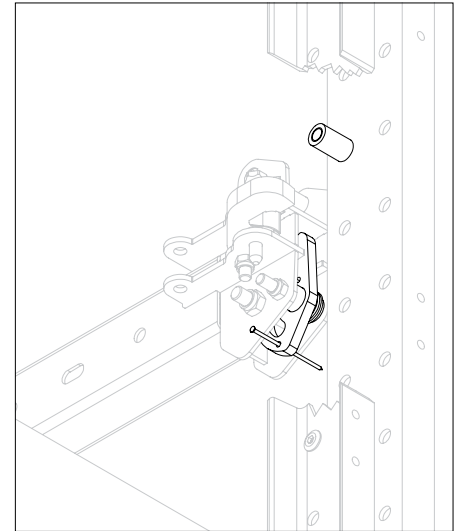

Fig. D4.04a

Troubleshooting

Problem	Cause	Measures
Guiding skirts cannot be closed.	– Climbing Rail is not completely in position in the Guide Shoe.	– Pull Climbing Rail with Guide-in Tool inwards.
	– Climbing rail spacing is not correct.	– Detach climbing enclosure and adjust spacing of Climbing Rail.
	– Slab Shoe spacing is not correct.	– Slightly loosen the fixing of the Guide Shoes, close the guiding skirts and tighten them using component tolerances. Alternatively: – Mount new anchoring with tie rods and Wingnut Counterplates through the slab.
Climbing unit does not lie on the planned Spacer on both sides.	<ul style="list-style-type: none"> – Climbing Rail rests on a Slab Shoe that is positioned below. – Slab distance is approx. a multiple of 50 cm. 	– Raise the climbing unit by approx. 6 cm using the crane. Deactivate the pawls of all Slab Shoes positioned below. Position climbing unit with the planned Spacer on the pawl of the top Slab Shoe.

Finishing Tasks

1. Detach crane lifting gear from a safe position, e.g. mobile scaffold. Alternatively, leave two-sling lifting gear attached to the climbing enclosure until it can be safely dismantled.
2. Supplement guardrails.
3. Dismantle trailing Slab Shoe, see Section "Dismantling Slab Shoe LPS" on Page 109.
4. Remove anchoring that is no longer needed, see Section "Dismantling the Anchoring" on Page 110.

Safety Instructions



Warning

- There is a risk of falling from unsecured slab edges.
- As a result of the moving procedure, leading edges are formed between the platforms.

A fall can result in serious injury or even death!

- ⇒ Mount guardrails before climbing.
- ⇒ Areas of risk are to be cordoned off.
- ⇒ Use personal protective equipment to prevent falls.
- ⇒ Keep Foldable Covers closed after assembling the climbing hydraulics.



Warning

Parts of the body can get caught between the Climbing Rail and Slab Shoe and become trapped. This can cause serious injury.

- ⇒ Do not take hold of anything between the Rail Guidance Shoes and Climbing Rails while the climbing enclosure is moving.



- The load-bearing capacity of the structural elements which carry the load-carrying Slab Shoes must be ensured!
- Do not transport persons, building materials or tools when moving with the crane. These could fall off and cause serious injury or even death.
- Material or other components must not protrude beyond the slab edge. This could hinder climbing or fall off.
- In the event of a malfunction, the climbing enclosure is to be set down in the next possible position and an authorised person is to be informed immediately!
- Install hydraulic hoses so that
 - no loops or knots are created,
 - no loops form beyond the edge of the slab,
 - they do not get tangled with the climbing platforms.
- Up to 2 units can be climbed at the same time.

Significant differences between Versions 1 and 2

With Version 1, the Slab Shoe must be swivelled into the projecting Climbing Rail before climbing begins and closed.

With Version 2, the Climbing Rail is pulled into the top Slab Shoe during the climbing procedure.

Initial Operation of the Climbing Hydraulics

See "Instructions for Use for LPS Climbing Device and Hydraulics".

Preparations

The self-climbing procedure takes place from the slab level with the middle Slab Shoe.

Carry out preparatory work as described in Section "D5 Moving by Crane" on Page 117; however, the Foldable Covers remain closed at this level until the climbing unit has been mounted!

In addition:

1. Prepare climbing hydraulics. See "Instructions for Use for LPS Climbing Device and Hydraulics".
2. Ensure hydraulic pump is available.
3. Lay out hydraulic hoses on the slab without any loops or entanglement.
4. Prepare Climbing Device LPS 30.

Hydraulic Diagram

See Fig. D5.01

The arrangement of the plug connectors and bushings of the quick couplers is clearly shown.

Remedial Measures for Malfunctions

See "Instructions for Use for LPS Climbing Device and Hydraulics"

- Uneven cylinder extension and retraction
- Cylinder sinks
- Hydraulic oil leaks
- Cylinder does not extend

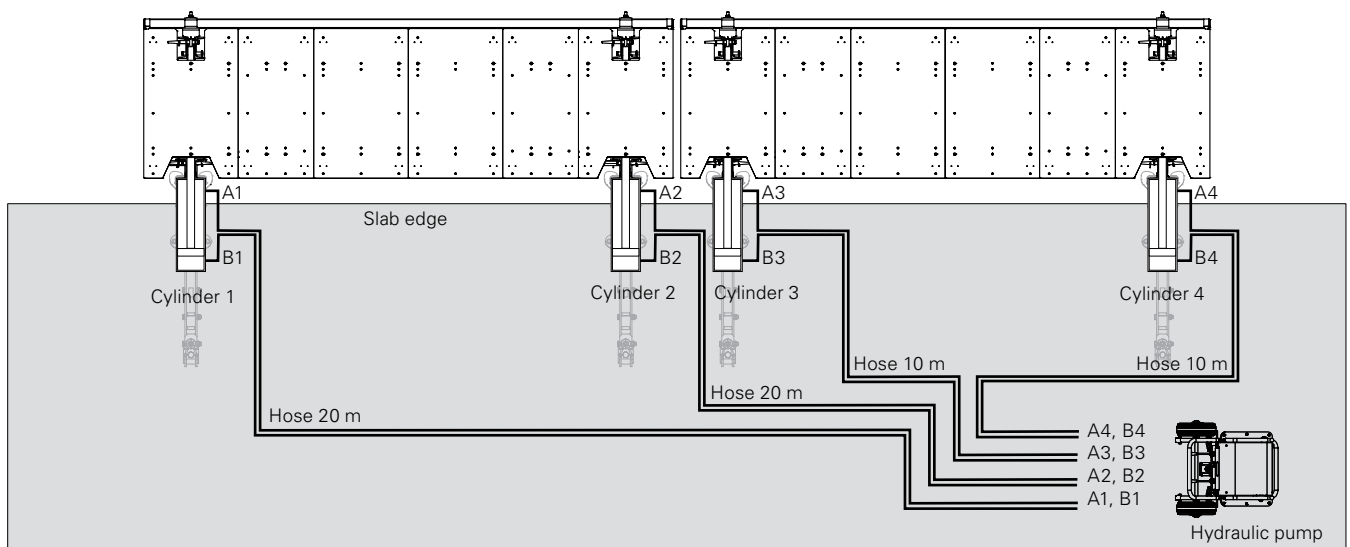

Fig. D5.01

Moving Procedure

For a detailed explanation of the individual steps, see Section "Self-Climbing Procedure" on Page 123.

1. Activate climbing pawls on the middle Slab Shoe (10b).
2. Only Version 1: insert Climbing Rails (2) into the top Slab Shoe (10a) using the Guide-In Tool and close the guiding skids. Deactivate the climbing pawl.
3. Insert climbing device (90) and engage with bolt of the middle Slab Shoe (10b).
4. Fold up Foldable Covers (40) and secure them by shifting laterally or by means of wiring.
5. All personnel to leave the climbing enclosure; control climbing procedure from a safe position.
6. Raise the climbing enclosure from the middle Slab Shoe with the Climbing Device LPS 30 kN (90) in 50 cm steps. (Fig. D5.02 + D5.02a)
7. Only Version 2: when the Climbing Rail (2) has reached the top Slab Shoe (10a):
 - Stop the climbing procedure and insert the Climbing Rail into the Slab Shoe.
 - Continue climbing.
8. After the required protection height has been reached:
 - Stop the climbing procedure.
 - Position the climbing unit with Spacer LPS 52 on the middle Slab Shoes.

Components

2	Climbing Rail-2 LPS
10	Slab Shoe-2 LPS
40	Foldable Cover
90	Climbing Device LPS 30 kN

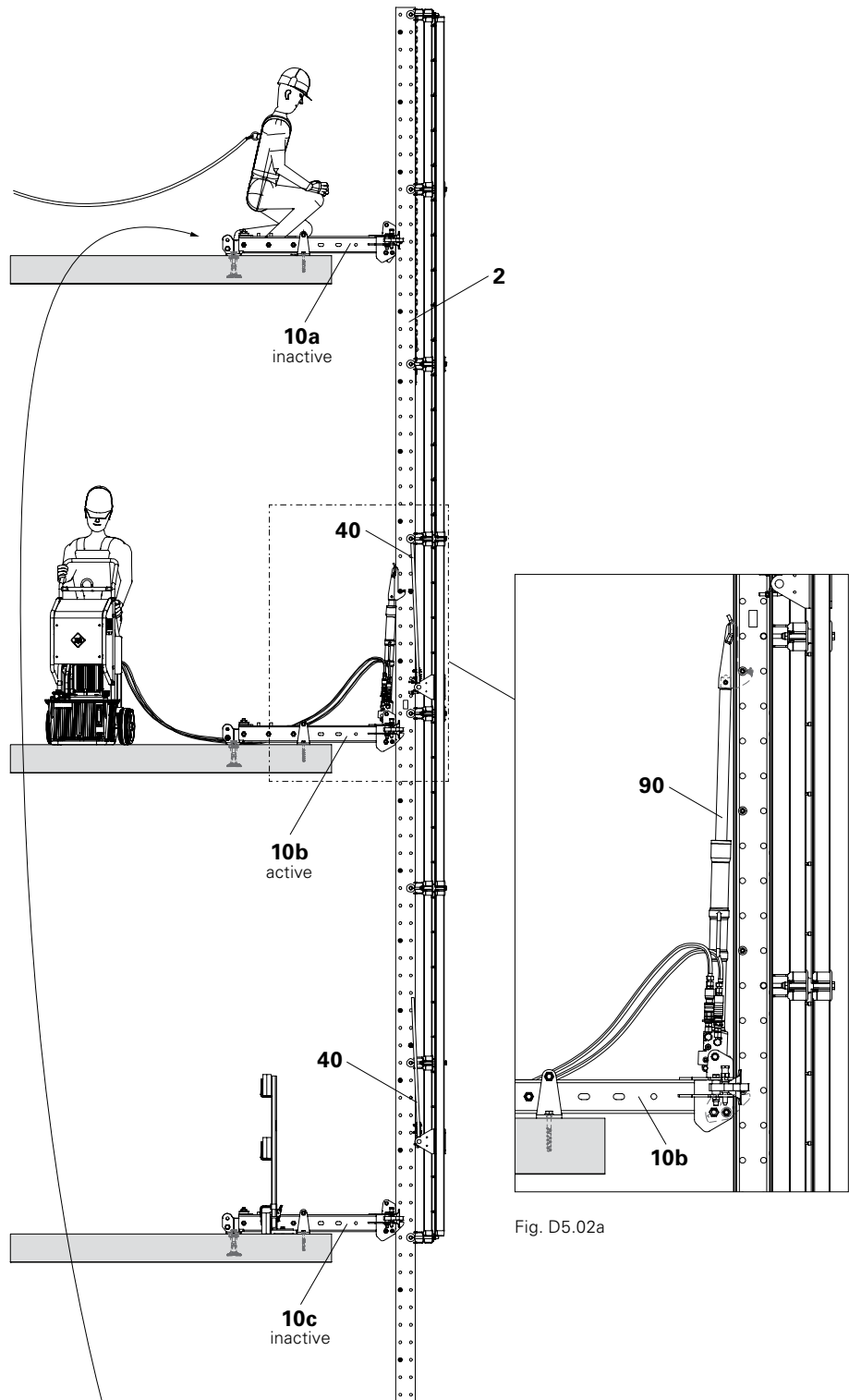

Fig. D5.02a

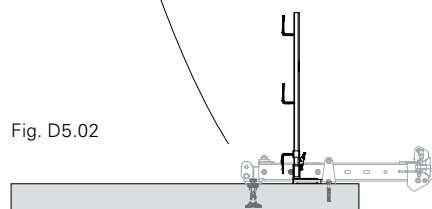

Fig. D5.02

Self-Climbing Procedure

Step 1

1. Remove Cover Mat from over the Slab Shoe.
2. Position the Climbing Device LPS (90) on the Bolts (10.5) of the middle Slab Shoe (10b) and engage. The climbing device is pressed against the Climbing Rail through spring force. Guide the claw into the Climbing Rail. (Fig. D5.03 + D5.03a)
3. Attach twin hoses to the hydraulic pump and create a short-circuit connection at the other end by coupling them together.
4. Switch on the hydraulic pump and flush the hose for approx. 1 minute by operating the hand valve.
5. Disconnect the hose ends from one another and connect to the cylinder.

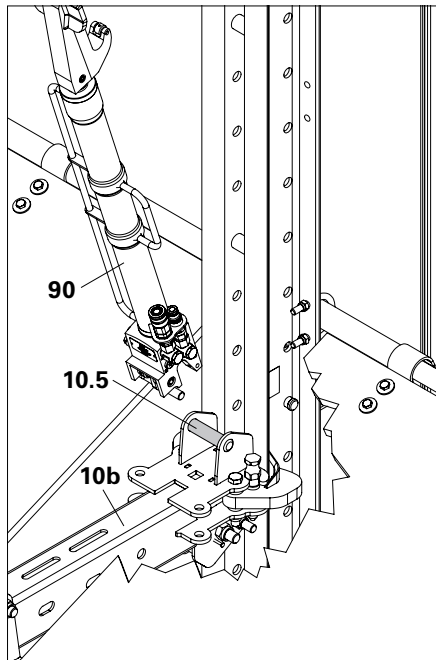

Fig. D5.03

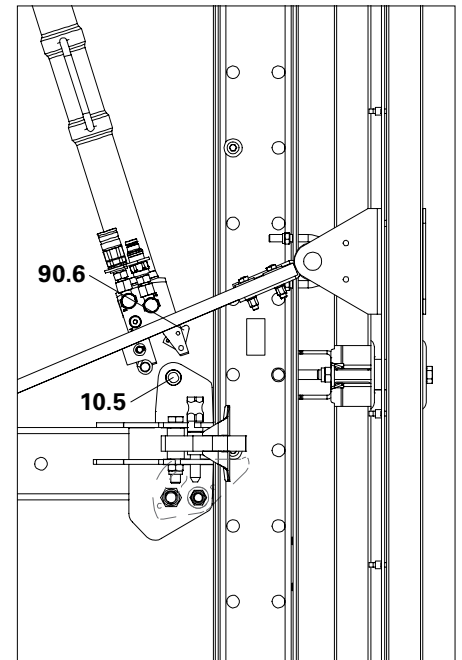

Fig. D5.03a



- Is the locking lever (90.6) engaged at the cylinder base?
- No possibility of the hydraulic hoses becoming entangled?

Components

2	Climbing Rail-2 LPS
10	Slab Shoe-2 LPS
10.5	Bolts
90	Climbing Device LPS 30 kN
90.6	Locking Lever

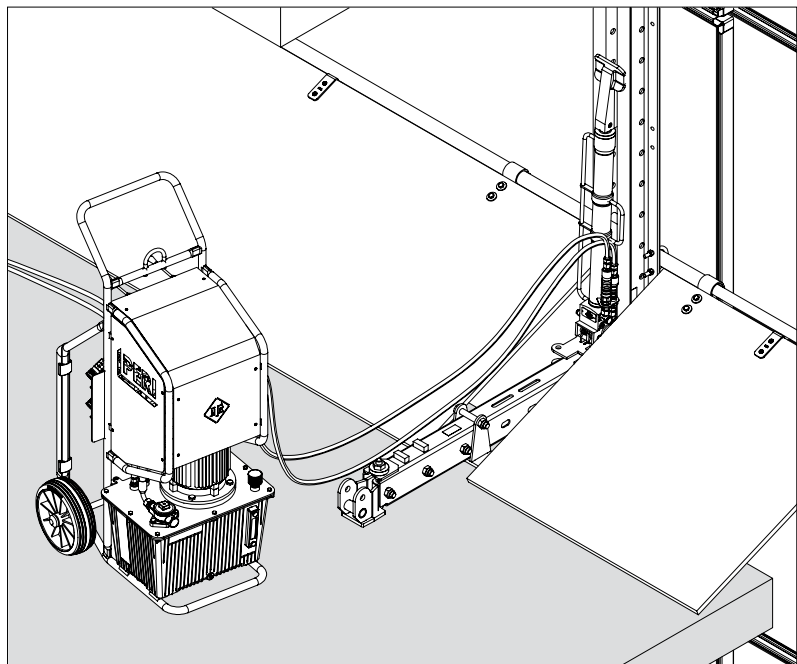

Fig. D5.03b

Step 2

Warning!

Use personal protective equipment to prevent falling from a height.

1. Fold up Foldable Covers (40) and secure by sliding laterally behind the Climbing Rail.
2. Extend the hydraulic cylinder (90) up to the first Spacer (2.1).
3. Load is now carried by the piston with claw (90.1). (Fig. D5.04)
4. If necessary, activate the climbing pawls of the bottom Slab Shoe (10b) and deactivate the others.



Are all claws engaged in the Spacers?



If the Foldable Covers (40) collide with the hoses or hydraulic climbing device during opening:

- Cut Cover Mat.

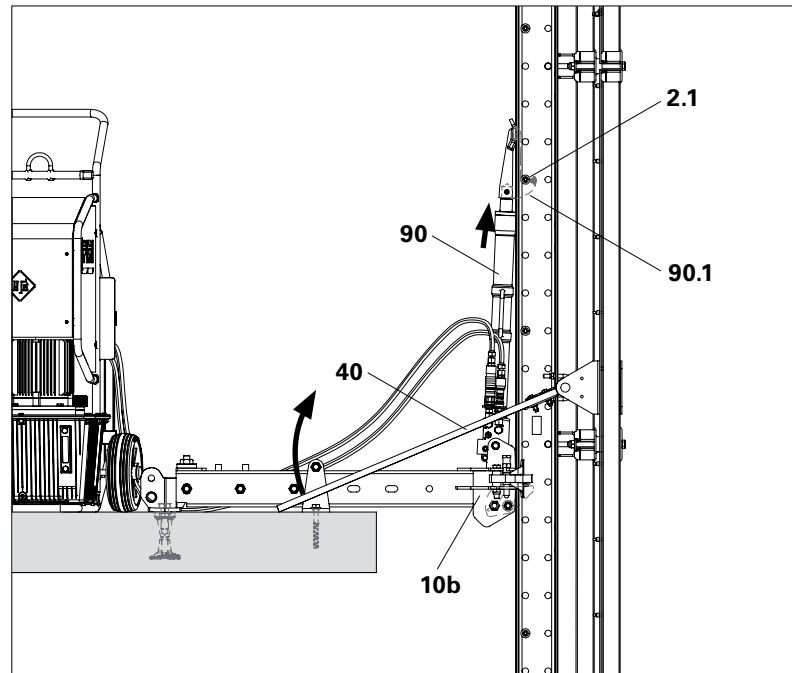

Fig. D5.04

Components

2.1	Spacer
10	Slab Shoe-2 LPS
40	Foldable Cover
90	Climbing Device LPS 30 kN
90.1	Claw

Step 3

1. Completely extend the hydraulic cylinder.
2. Climbing pawl (10.2) in the Slab Shoe is pressed inwards by the Spacer when climbing past, then unfolded again by means of the spring force (audible click). (Fig. D5.05)



Are the climbing pawls (10.2) of all middle Slab Shoes (10b) engaged in the Climbing Rail?

If not:

- Completely extend the hydraulic cylinder. Due to the end position compensation, the following cylinder moves very slowly.
- Climb back, remove cylinder and bleed.

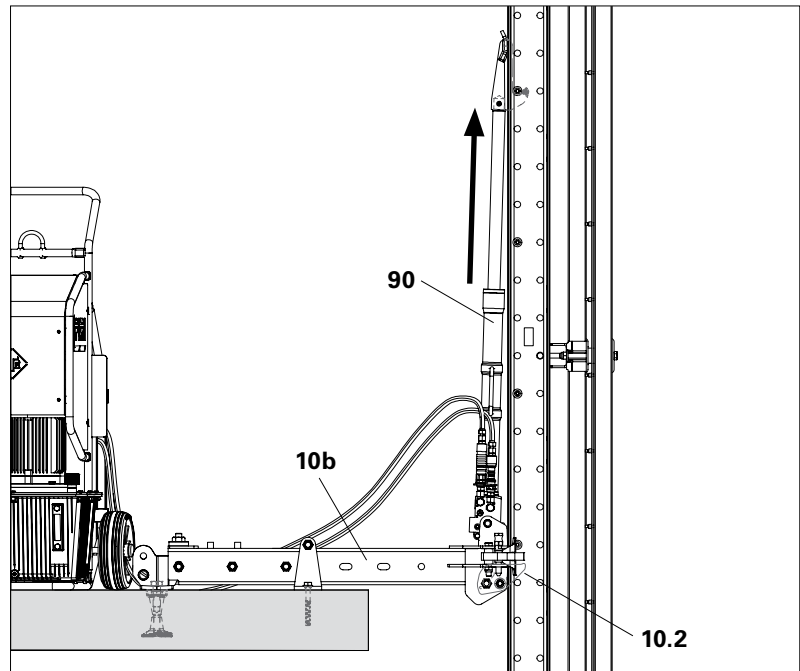

Fig. D5.05

Step 4

1. Retract all hydraulic cylinders until:
 - the load is carried by the climbing pawl (10.2) in the middle Slab Shoe (10b),
 - claw is relieved of the Spacer.

Components

-
- | | |
|-------------|---------------------------|
| 10 | Slab Shoe-2 LPS |
| 10.2 | Climbing Pawl |
| 90 | Climbing Device LPS 30 kN |
-

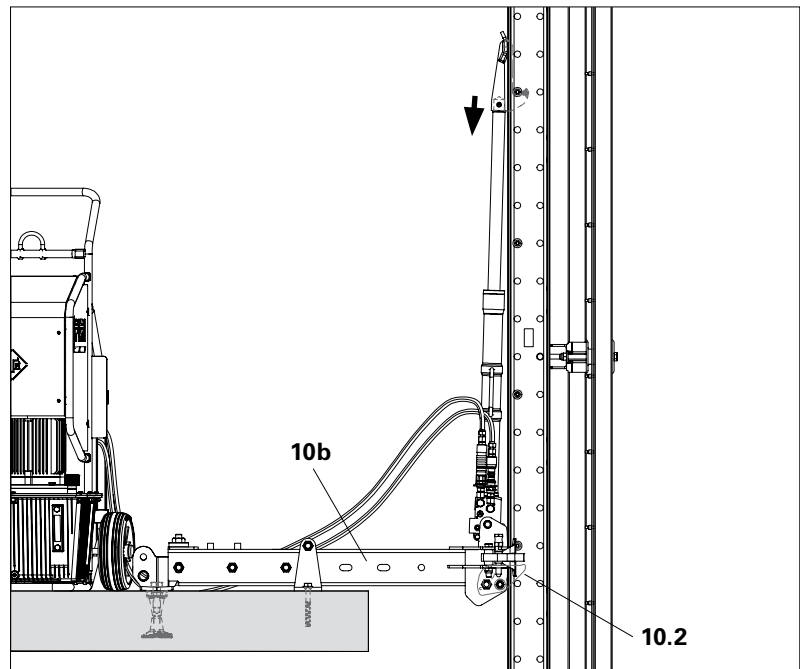

Fig. D5.05a

Step 5

1. Retract hydraulic cylinder until it tilts backwards, claw (90.1) slides past the Spacers positioned underneath and engages again below. (Fig. D5.06)



Are all claws under the Spacers correctly engaged?

Otherwise press down by hand.

If necessary, further retract hydraulic cylinder.

Step 6

1. Extend hydraulic cylinder.
→ Claw grips Spacer and raises the Climbing Rail.
2. By repeating Steps 3 to 6 several times, the climbing unit is gradually climbed upwards in increments of 50 cm.



If the hydraulic hoses become taut or entangled, immediately stop the climbing procedure and eliminate the problem!

Step 7 (Version 2)

When reaching the top climbing shoe:

1. Stop the climbing procedure.
2. Pull Climbing Rail inwards by means of the Guide-in Tool RCS (98).
3. Close foldable skids of the top Slab Shoe (10a). Deactivate climbing pawls.
4. Remove Guide-in Tool.
5. Continue climbing procedure. (Fig. D5.06)

Components

- | | |
|-------------|-----------------|
| 2.1 | Spacer |
| 10 | Slab Shoe-2 LPS |
| 90.1 | Claw |
| 98 | Guide-in Tool |

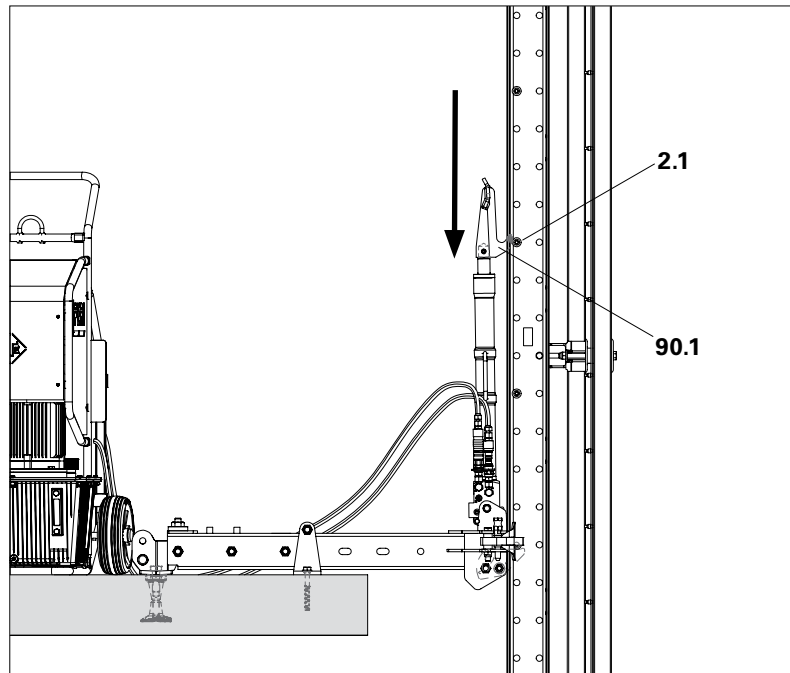

Fig. D5.06

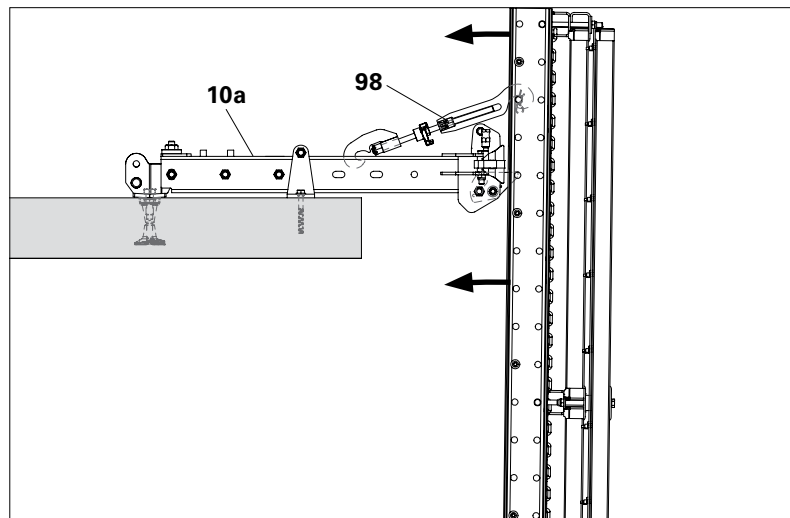

Fig. D5.07

Step 8

During the final lift:

1. Extend hydraulic cylinders until all climbing pawls of the middle Slab Shoe engage in the correct Spacers.



Are the climbing pawls (10.2) of all middle Slab Shoes (10b) engaged?

Components

-
- | | |
|-----|---------------------------|
| 2.1 | Spacer |
| 10 | Slab Shoe-2 LPS |
| 40 | Foldable Cover |
| 90 | Climbing Device LPS 30 kN |
-

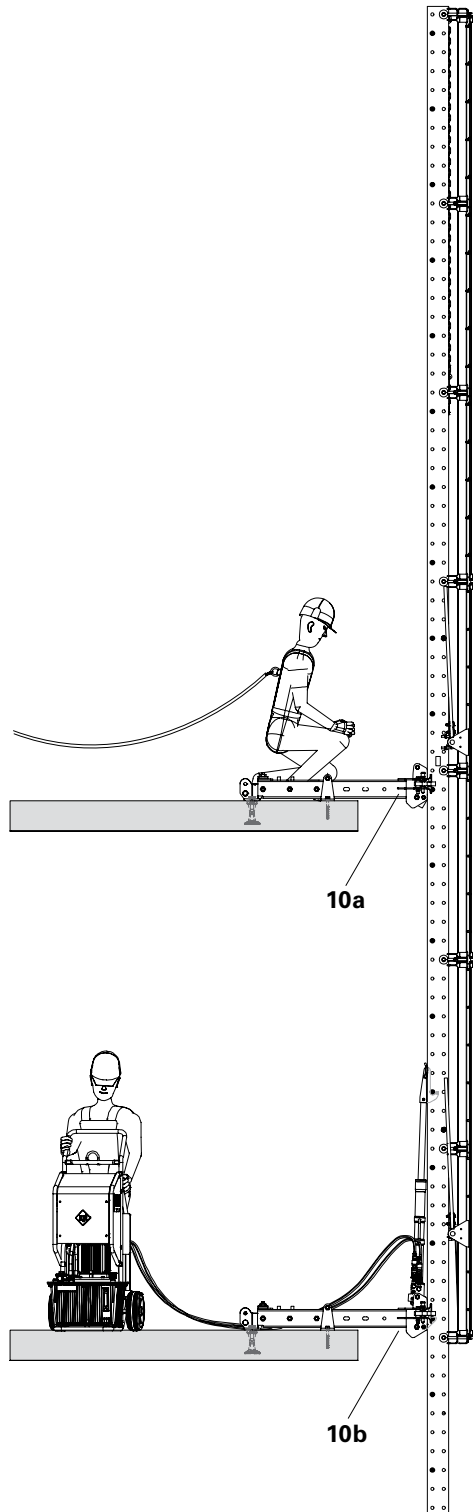
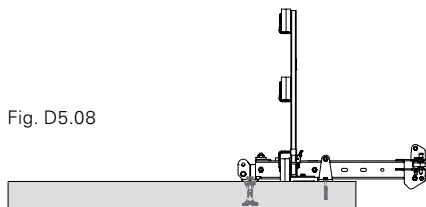

Fig. D5.08



Step 9

1. Completely retract all hydraulic cylinders:
 - Load is carried by the climbing pawl in the middle Slab Shoe (10b),
 - Claw (90.1) is released from the Spacer (2.1).
2. Detach hydraulic hoses from the climbing device using the quick couplers.
3. Close the Foldable Covers (40).
4. Tilt the climbing device backwards, operate the locking lever (90.6) on the cylinder base and lift out the climbing device. (Fig. D5.09)
5. Transport the hydraulic pump, climbing device and hydraulic hoses to the next climbing enclosure.



In order to prevent the locking lever immediately engaging again after releasing, press the climbing device slightly to the side.



When the hydraulic cylinders are not being used, always completely retract the pistons.

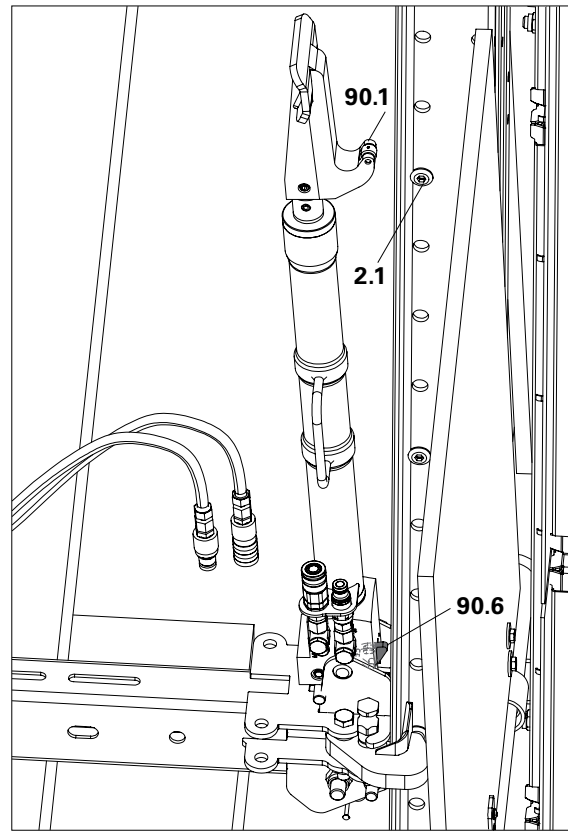

Fig. D5.09

Components

-
- 10.2 Climbing Pawl
 - 90.1 Claw
 - 90.6 Locking Lever
-

Bleeding the Oil-Hydraulic System

See also "Instructions for Use for LPS Climbing Device and Hydraulics".

In order to ensure a reliable operation of the system, it must be completely bled during the initial commissioning on site, after tubes and hoses have been replaced, or after maintenance work has been carried out on the cylinder. In the process, the oil level in the hydraulic pump must always be checked and topped up as required.

Bleeding

1. Attach hydraulic twin hose (92) on the hydraulic pump side.
2. Connect the pair of couplings to the climbing device (90) at the other end.
3. Place climbing device in an upright position.
4. Completely extend the cylinder to displace the air pockets on the rod side. (Fig. D5.11a)
5. Disconnect the climbing device and short-circuit the hydraulic twin hose.
6. Switch on the hydraulic pump and flush hydraulic twin hose for approx. 1 minute by operating the hand valve. (Fig. D5.11b)
7. Disconnect the hose ends from one another and reconnect to climbing device.
8. Turn climbing device upside down.
9. Completely retract the cylinder in order to displace the air pockets on the piston side. (Fig. D5.11c)
10. Disconnect the climbing device and once again flush the hydraulic twin hose for approx. 1 minute using a short-circuit connection. (Fig. D5.11d)
11. Extend and retract the cylinder pair several times to check synchronisation.

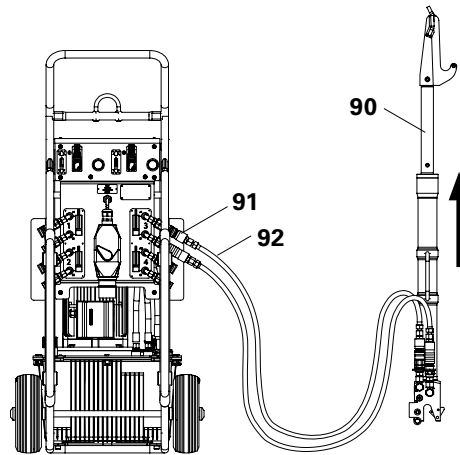

Fig. D5.11a

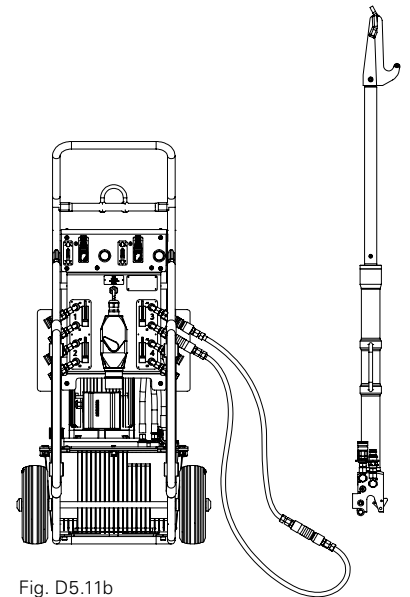

Fig. D5.11b

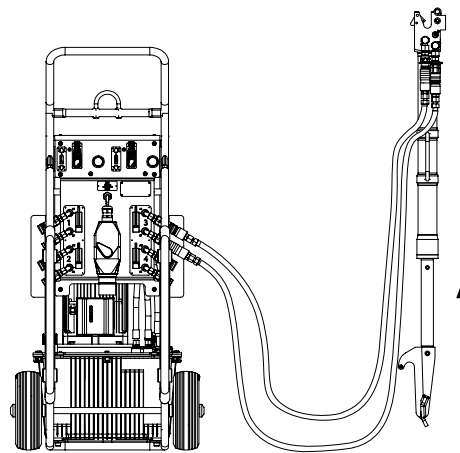

Fig. D5.11c

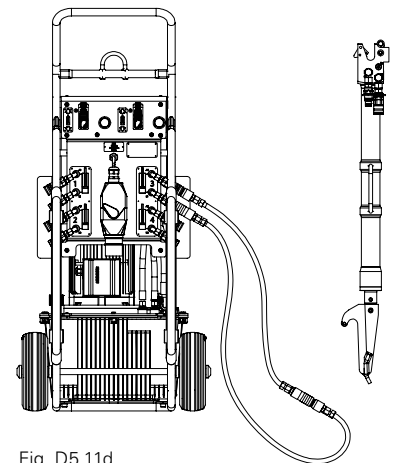

Fig. D5.11d

Components

- | | |
|-----------|------------------------------|
| 90 | Climbing Device |
| 91 | Hydraulic Pump RCS 4x190 bar |
| 92 | Hydraulic Twin Hose |

Removing the Climbing Enclosure



Warning

As a result of removing the climbing enclosure, unsecured building edges are formed.

A fall can result in serious injury or even death!

- ⇒ Install guardrails before removing the climbing enclosure.
- ⇒ Areas of risk are to be cordoned off.
- ⇒ Use personal protective equipment to prevent falls.

Preparations

1. Remove connections between the climbing enclosures.
2. Dismantle formwork in the area of the slab edge.
3. Mount guardrails (99) on all unsecured slab edges.
4. Remove Cover Mats, fold up Foldable Covers and secure by sliding laterally behind the Climbing Rail.
5. Remove or secure all loose components.
6. Install Crane Eye BR-2 2.5 t, see Section "Assembly of Attachment Points" on Page 69.
7. Install Compression Brace, see Section "Moving by Crane" on Page 41.
8. Attach guide ropes to the climbing enclosure.
9. Attach crane lifting gear to Crane Eye BR-2.
(Fig. E.01)

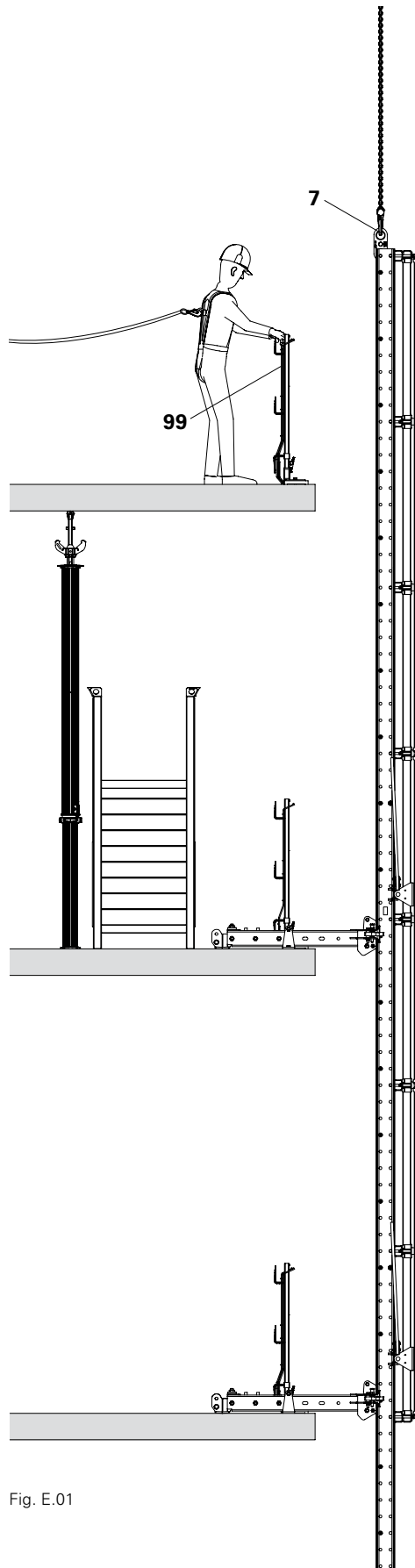

Fig. E.01

Removing the Climbing Enclosure



Warning

Hands can get caught between the Climbing Rail and Slab Shoe and become trapped. This can cause serious injury.

- ⇒ Do not take hold of the Rail Guidance Shoes and Climbing Rails while the climbing enclosure is moving.
- ⇒ Do not open the foldable skids if the Climbing Rail is pressing against them.

1. Personnel vacate platforms of the climbing enclosure.
2. Open guiding skids of the bottom Slab Shoe (10c).
3. Lift climbing enclosure slightly with the crane in order to relieve the middle Slab Shoes (10b).
4. Open the guiding skids on the middle Slab Shoes (10b).
5. Move climbing enclosure away from the building with the crane and transport to suitable dismantling area.
6. Dismantle the remaining Slab Shoes (10b, 10c) and remove the anchoring.
7. Complete guardrails.
(Fig. E.02)

Components

7	Crane Eye BR-2 2.5 t
10	Slab Shoe-2 LPS
99	Guardrails

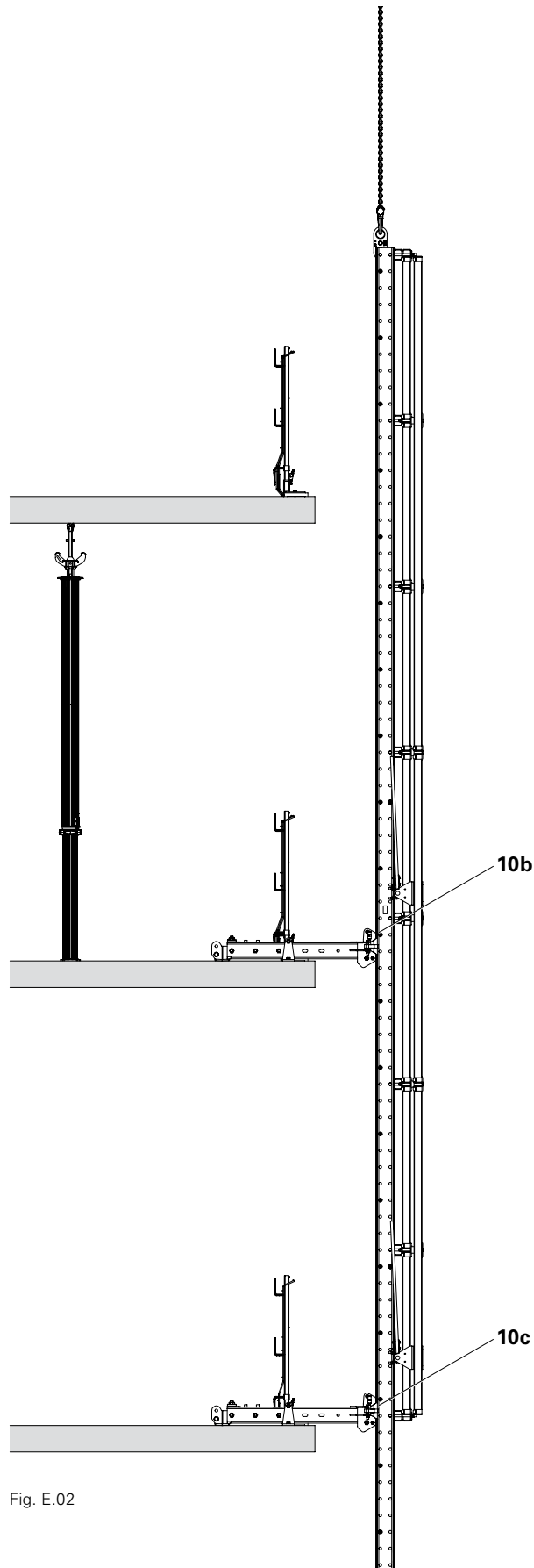

Fig. E.02

Dismantling the Climbing Enclosure

Return of transportable units

1. Push Telescopic Screens together to form a transportable size.
2. Dismantle the platform extensions.
3. Dismantle the extensions of the cover flaps.
4. Dismantle the extensions of the finishing platforms, dismantle finishing platforms or secure in the transport position using Fitting Pins.
5. Secure or remove moving parts.
6. Load with the Screen Adapter Stacking LPS if not completely dismantled, see Section "C1 Pre-Assembly" on Page 86 as well as Instructions for Use for Screen Adapter Stacking LPS 60. (Fig. E.04 + E.04a)

Dismantling

1. Place climbing enclosure with Screen Elements facing upwards on the dismantling area.
2. Dismantle Telescopic Screen, Screen Adapter and Screen Element.
3. Dismantle finishing platform and Telescope Beam.
4. Dismantle Foldable Covers and scaffold tube.
5. Dismantle enclosure post.
6. Dismantle working platforms.
7. Dismantle Climbing Rail Connector and Crane Eye.
8. Put Spacers back in original position.

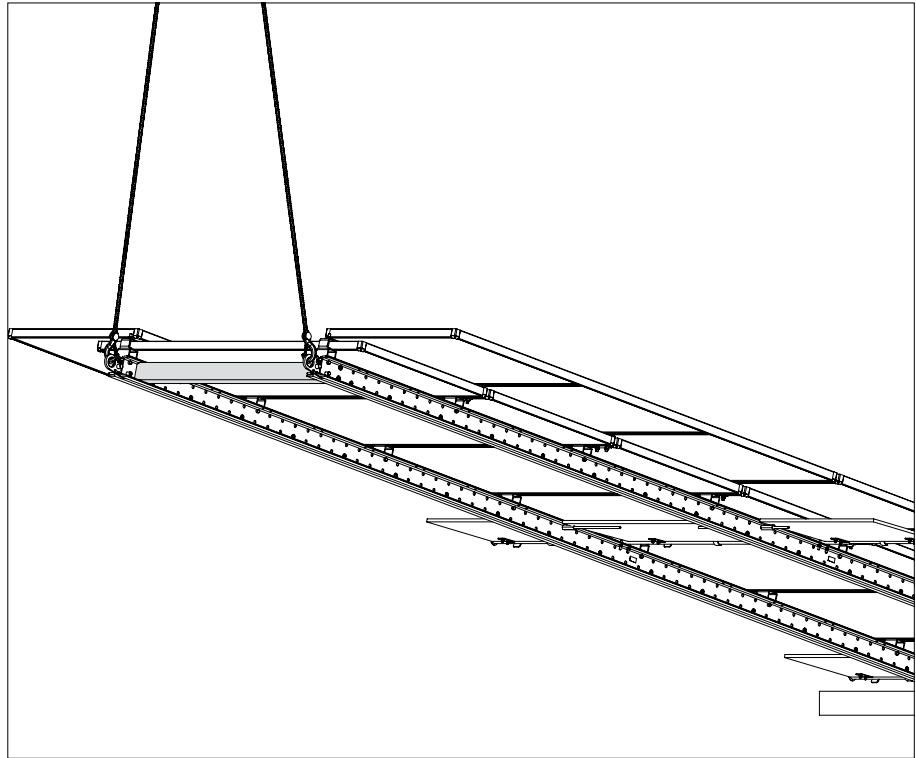

Fig. E.03

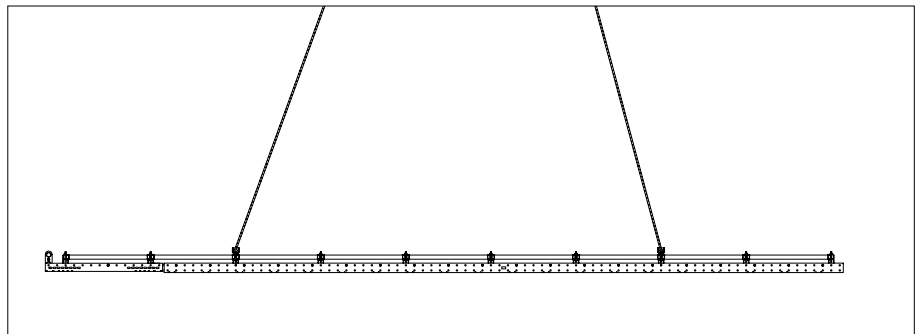

Fig. E.04

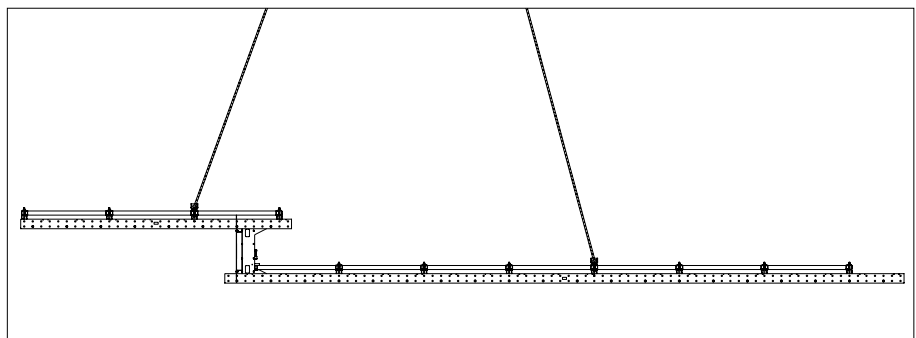

Fig. E.04a



- Spacers in the Climbing Rails must be moved back to their original positions. Failing to do so can lead to considerable malfunctions during climbing operations with corresponding additional assembly work during the next use due to displaced or additional Spacers.
- With rental equipment, PERI may invoice the client for the costs incurred for the dismantling work.
- Non-reusable materials are to be disposed of in a suitable and environmentally-friendly manner.

LPS Light Climbing System



Item no.	Weight kg
130268	128.000
130265	240.000
130271	320.000

Climbing Rails-2 LPS
Climbing Rail-2 LPS 398
Climbing Rail-2 LPS 748
Climbing Rail-2 LPS 998
 Steel profile with Spacer-2 LPS 52.

L
3980
7480
9980

Technical Data
 $W_y = 160.7 \text{ cm}^3$, $I_y = 1124.8 \text{ cm}^4$
 Steel grade S460.

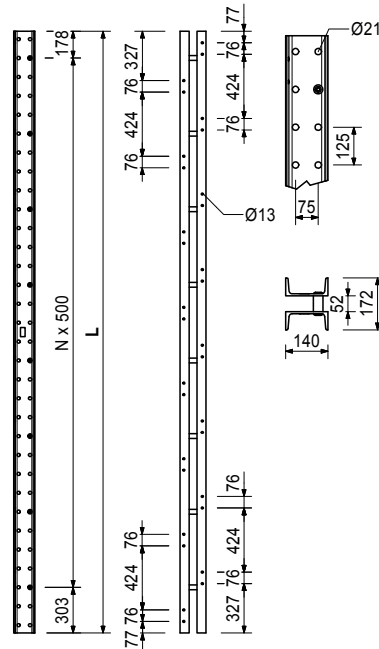

130262	0.414
--------	-------

Spacer-2 LPS 52
 Spacer for Climbing Rails-2 LPS.

Technical Data
 Allen key SW 10.

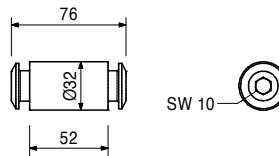
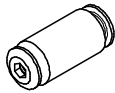

117245	9.190
--------	-------

Rail Connector LPS
 For rigid connection of Climbing Rails LPS.

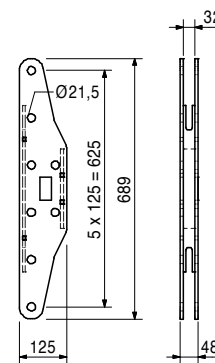

Accessories

104031	0.462
018060	0.014
127875	2.000

Fitting Pin Ø 21 x 120
Cotter Pin 4/1, galv.
Screen Support LPS M20

Item no.	Weight kg
127875	2.000

Screen Support LPS M20

For vertical support of Screen Elements LPS in combination with Rail Connector LPS or Climbing Rail Connector RCS/LPS 73.

Complete with

2 pc. 781053 Nut ISO 7040 M20-8, galv.
2 pc. 114662 Bolt ISO 4017 M20 x 120-8.8, galv.

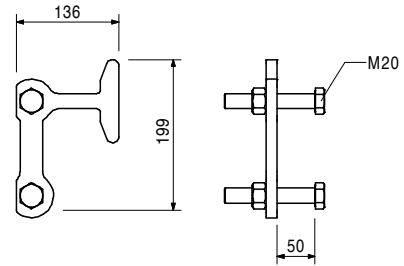
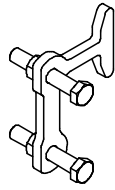

124682	5.400
--------	-------

Rail Connector SRU/LPS

For rigid connection of Climbing Rail LPS and Steel Waler Universal SRU U120.

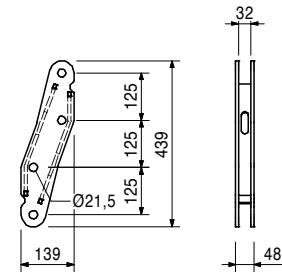

Accessories

104031	0.462
018060	0.014

Fitting Pin Ø 21 x 120

Cotter Pin 4/1, galv.

104031	0.462
--------	-------

Fitting Pin Ø 21 x 120

For different connections.

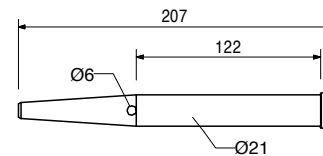
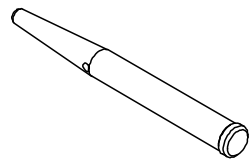

Accessories

018060	0.014
--------	-------

Cotter Pin 4/1, galv.

018060	0.014
--------	-------

Cotter Pin 4/1, galv.



Item no.	Weight kg	
103868	18.100	Steel Walers Universal SRU
103871	24.200	Steel Waler Universal SRU U120, l = 0.72 m
103874	30.900	Steel Waler Universal SRU U120, l = 1.22 m
103877	38.100	Steel Waler Universal SRU U120, l = 1.47 m
103886	44.700	Steel Waler Universal SRU U120, l = 1.72 m
103889	52.000	Steel Waler Universal SRU U120, l = 1.97 m
103898	58.600	Steel Waler Universal SRU U120, l = 2.22 m
103892	65.600	Steel Waler Universal SRU U120, l = 2.47 m
103929	72.000	Steel Waler Universal SRU U120, l = 2.72 m
103903	81.000	Steel Waler Universal SRU U120, l = 2.97 m

Universal Steel Waler Profile U120 used as waling for girder wall formwork and for diverse special applications. With adjustable spacers.

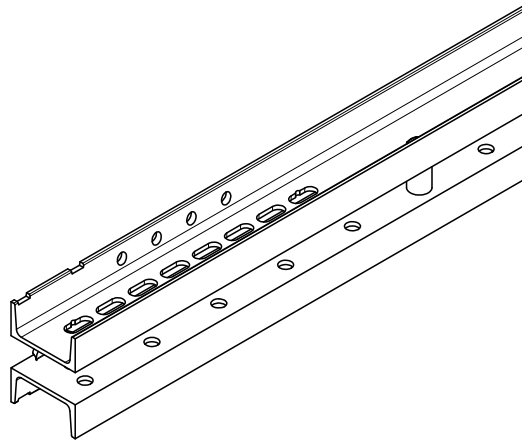

L
722
972
1222
1472
1722
1972
2222
2472
2722
2972

Note
Permissible load: see PERI Design Tables.

Technical Data
U120: $W_y = 121.4 \text{ cm}^3$, $I_y = 728 \text{ cm}^4$.

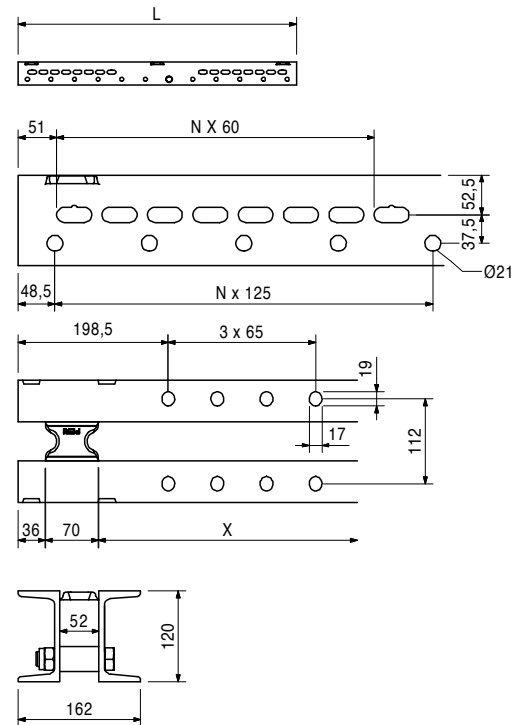

			L
127568	41.000	Screen Elements LPS	
127572	47.600	Screen Element DX LPS 250 x 123	2500
127576	54.500	Screen Element DX LPS 300 x 123	3000
127580	77.600	Screen Element DX LPS 350 x 123	3500
		Screen Element DX LPS 500 x 123	5000

Standard protection panels. Duplex coated. Mesh size 40 x 17 x 3.

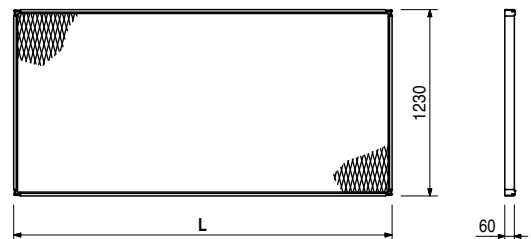
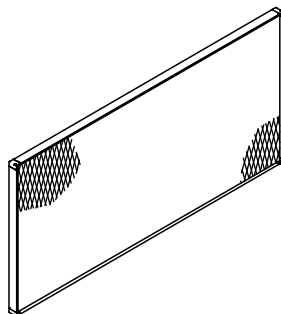

Item no.	Weight kg
127556	46.500

Telescopic Screen DX LPS 123 x 248

Mesh protection panel with telescopic function or as side protection on Material Platforms RCS-MP. Duplex coated. Mesh size 40 x 17 x 3.

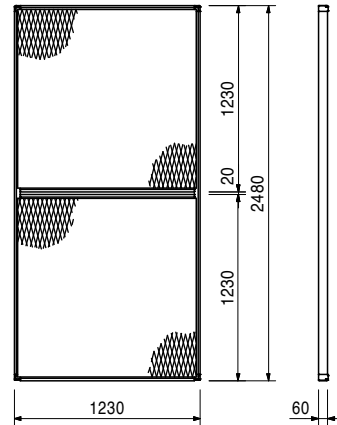
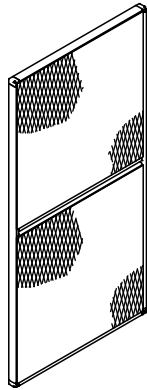

127560	69.900
--------	--------

Telescopic Screen DX LPS 123 x 373

Mesh protection panel with telescopic function or as side protection on Material Platforms RCS-MP. Duplex coated. Mesh size 40 x 17 x 3.

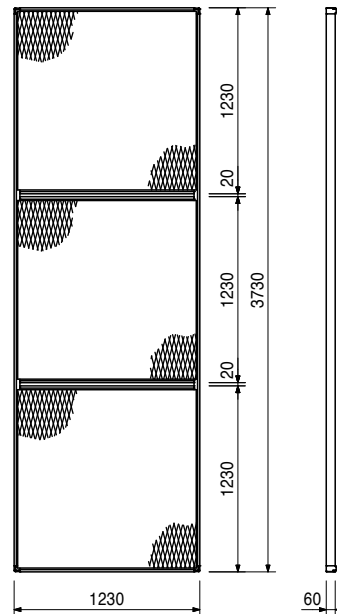
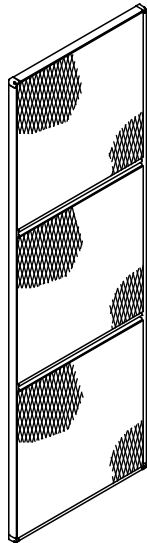

Item no.	Weight kg
127564	93.100

Telescopic Screen DX LPS 123 x 498

Mesh protection panel with telescopic function.
Duplex coated. Mesh size 40 x 17 x 3.

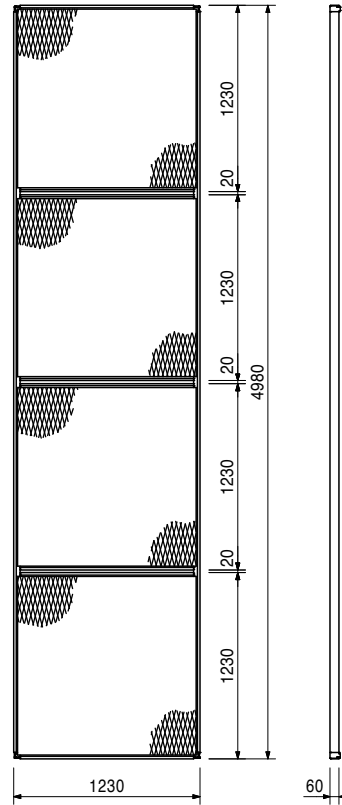
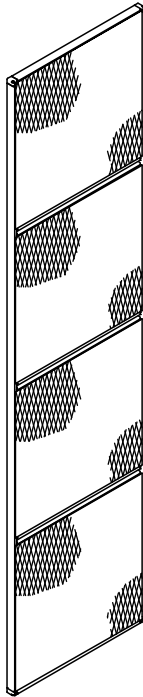

117152	2.150
--------	-------

Screen Adapter Double LPS 60

For connection of two standard Screen Elements LPS to Climbing Rail LPS or RCS.

Complete with

- 1 pc. 126003 Ring Bolt M16 x 200, galv.
- 1 pc. 113349 Washer ISO 7094 100 HV, A 16, galv.
- 1 pc. 070890 Nut ISO 7040 M16-8, galv.

Note

Wrench size SW 24.

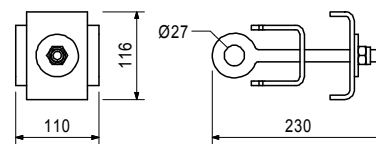
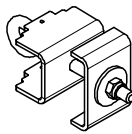

710226	0.340
781053	0.065
104031	0.462
022230	0.033

Accessories

Bolt ISO 4014 M20 x 90-8.8, galv.

Nut ISO 7040 M20-8, galv.

Fitting Pin Ø 21 x 120

Cotter Pin 5/1, galv.

Item no.	Weight kg
117166	2.290

Screen Adapter Single LPS 60

For connection of single Screen Element LPS to Climbing Rail LPS or RCS.

Complete with

- 1 pc. 126003 Ring Bolt M16 x 200, galv.
- 1 pc. 113349 Washer ISO 7094 100 HV, A 16, galv.
- 1 pc. 070890 Nut ISO 7040 M16-8, galv.

Note

Wrench size SW 24.

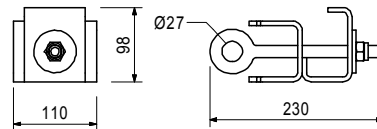
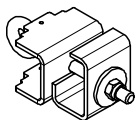

Accessories

710226	0.340
781053	0.065
104031	0.462
022230	0.033

Bolt ISO 4014 M20 x 90-8.8, galv.

Nut ISO 7040 M20-8, galv.

Fitting Pin Ø 21 x 120

Cotter Pin 5/1, galv.

127600	2.350
--------	-------

Screen Adapter Telescope-2 LPS

For connection of Telescopic Screen LPS to standard Screen Element LPS. Telescopic range max. 1.05 m.

Complete with

- 2 pc. 070890 Nut ISO 7040 M16-8, galv.

Note

Wrench size SW 24.

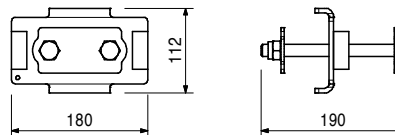
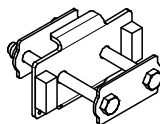

117165	5.730
--------	-------

Screen Adapter Combi LPS 60

For connection of Telescopic Screen LPS to standard Screen Element LPS and to Climbing Rail LPS or RCS. Telescopic range max. 0.87 m.

Complete with

- 1 pc. 126003 Ring Bolt M16 x 200, galv.
- 1 pc. 113349 Washer ISO 7094 100 HV, A 16, galv.
- 2 pc. 070890 Nut ISO 7040 M16-8, galv.

Note

Wrench size SW 24.

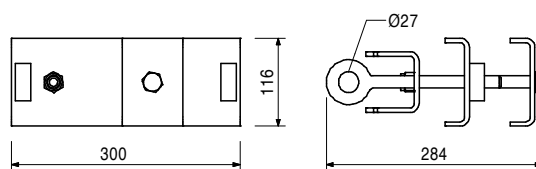
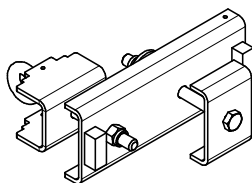

Accessories

710226	0.340
781053	0.065
104031	0.462
022230	0.033

Bolt ISO 4014 M20 x 90-8.8, galv.

Nut ISO 7040 M20-8, galv.

Fitting Pin Ø 21 x 120

Cotter Pin 5/1, galv.

Item no.	Weight kg
129796	8.730

Screen Adapter Stacking LPS 60

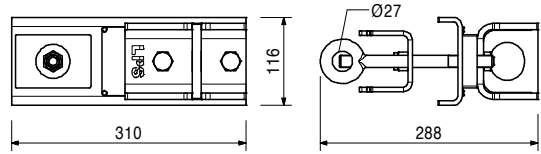
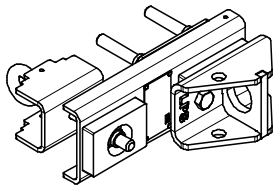

Accessories

104031	0.462
018060	0.014

Fitting Pin Ø 21 x 120
Cotter Pin 4/1, galv.

128842	1.820
--------	-------

Edge Screen Adapter Telescope LPS

For the edge connection of telescopic screens to standard Screen Elements LPS at the very top and bottom. Telescopic range max. 1.05 m.

Complete with

2 pc. 118533 Bolt ISO 4017 M10x030-8.8, galv
2 pc. 780356 Nut ISO 7042 M10-8, galv.
2 pc. 710231 Bolt ISO 4017 M16 x 30-8.8, galv.

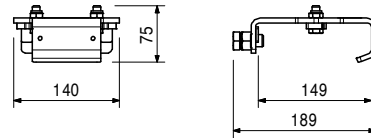
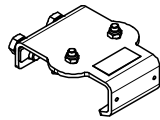

117535	4.650
--------	-------

Screen Adapter Corner LPS

For right angle connection of Telescopic Screen LPS to other screen elements.

Complete with

2 pc. 113349 Washer ISO 7094 100 HV, A 16, galv.
4 pc. 710229 Nut ISO 4032 M16-8, galv.
2 pc. 710929 Ring for Chain FW

Note

Wrench size SW 24.

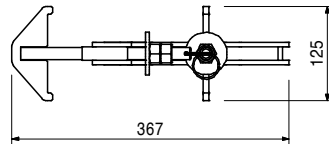
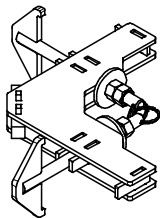

128804	3.150
--------	-------

Edge Screen Adapter Corner LPS

For right-angled edge connection of Telescopic Screens LPS to other screen elements at the very top and bottom.

Complete with

4 pc. 710231 Bolt ISO 4017 M16 x 30-8.8, galv.

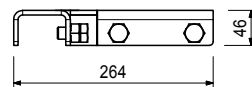
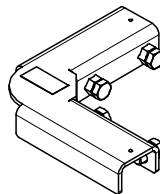

Item no.	Weight kg
----------	-----------

125971	2.300
125945	3.460

Cover Strips LPS
Cover Strip LPS 20 x 248
Cover Strip LPS 20 x 373

L
 2480
 3730

Elastic covering for closing gaps between screen elements.

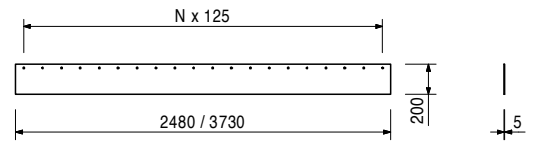
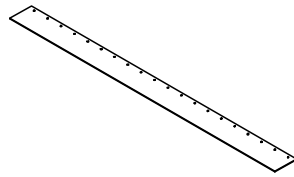

Accessories

126268	0.003
--------	-------

Cable Binder PA 6.6 SW 203 x 7.6

125973	12.400
--------	--------

Cover Strip Rubber 0.20 x 10 m

Universal elastic covering for closing gaps between platforms.

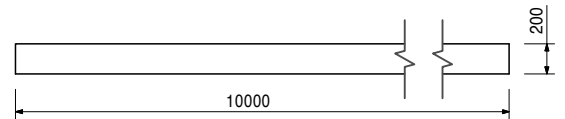
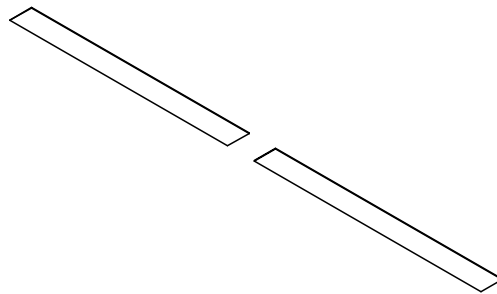

126268	0.003
--------	-------

Cable Binder PA 6.6 SW 203 x 7.6

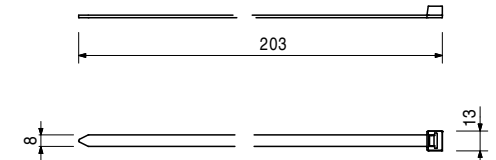
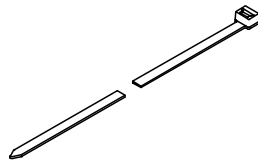

Item no.	Weight kg
127053	0.915

Cover Clip Profile LPS 110

To secure elastic covering for gaps between climbing units with Mesh Panel Enclosure LPS.

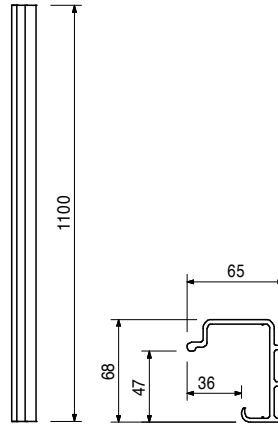

Accessories

127060	7.500
127061	17.250

Draw-in Profile LPS 20/55, l = 15 m

Draw-in Profile LPS 18/93, l = 15 m

127060	7.500
--------	-------

Draw-in Profile LPS 20/55, l = 15 m

Elastic rubber profile to cover gaps up to 50 mm.

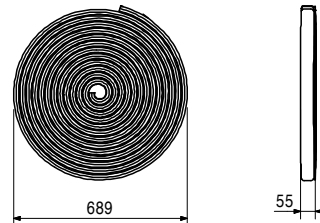

127061	17.250
--------	--------

Draw-in Profile LPS 18/93, l = 15 m

Elastic rubber profile to cover gaps up to 90 mm.

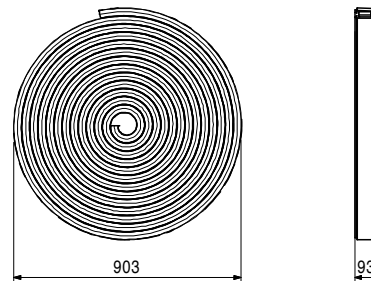
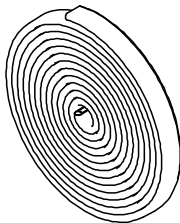

LPS Light Climbing System



Item no. Weight kg

125981	93.000
125983	113.000
125982	133.000
125980	193.000

Platforms LPS, galv.
Platform LPS 250, galv.
Platform LPS 300, galv.
Platform LPS 350, galv.
Platform LPS 500, galv.

Working platform; steel platform cover. Platform covering consisting of Platform Cover Bracket LPS 62.5 and Platform Cover LPS 50 and 62.5 according to platform length.

L	X	A
2500	1875	1250
3000	2375	1750
3500	2875	2250
5000	4375	3750

Note

Complete with:
 125991 Over-Head Screw ISO 7380 M10 x 25-10.9, galv
 780356 Nut ISO 7042 M 10-8, galv.

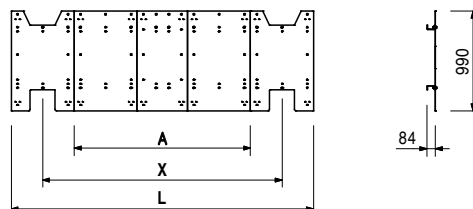
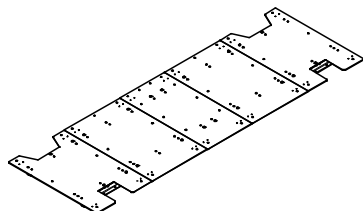

126197	7.600
124575	5.400

Platform Beams LPS
Platform Beam LPS 173
Platform Beam LPS 123

For supporting Platform Coverings LPS.

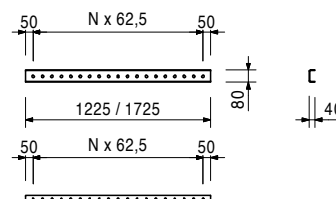
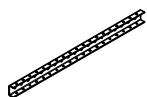

Accessories

710231	0.077
710229	0.033

Bolt ISO 4017 M16 x 30-8.8, galv.
Nut ISO 4032 M16-8, galv.

117935	14.300
--------	--------

Platform Cover LPS 37.5 x 99, galv.
 Platform cover plate for adjustment.

Note

Allen Key SW 6.
 Wrench size SW 16.

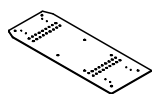

Accessories

125991	0.023
780356	0.011

Oval-Head Screw ISO 7380 M10 x 25-10.9, galv
Nut ISO 7042 M10-8, galv.

Item no.	Weight kg
125974	18.800

Platform Cover LPS 375 x 1075, galv.
 Platform cover plate for adjustment in telescope areas.

Note
 Allen Key SW 6.
 Wrench size SW 16.

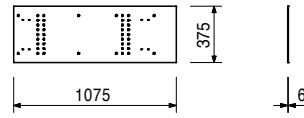
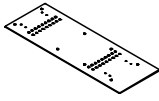

Accessories

125991	0.023
780356	0.011

Oval-Head Screw ISO 7380 M10 x 25-10.9, galv
Nut ISO 7042 M10-8, galv.

126611	20.300
--------	--------

Platform Cover Corner LPS 105 x 105, galv.
 For the extension of Platforms LPS in corner areas on pavements. Connection on Platform Beams LPS 123 or 173.

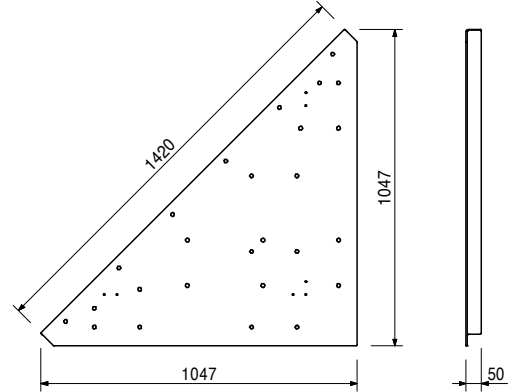
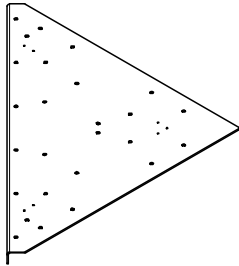

Accessories

125991	0.023
780356	0.011

Oval-Head Screw ISO 7380 M10 x 25-10.9, galv
Nut ISO 7042 M10-8, galv.

Item no.	Weight kg
130212	16.400

Platform Bracket LPS

Bracket for fixing Platform LPS to Climbing Rails LPS.

Complete with

- 2 pc. 125991 Oval-Head Screw ISO 7380 M10 x 25-10.9, galv
- 2 pc. 780356 Nut ISO 7042 M10-8, galv.
- 1 pc. 126248 Castle Nut M16 DIN 935-8, galv.
- 1 pc. 126249 Bolt ISO 4017-M16x130
- 1 pc. 126091 Sleeve ISO 8752 10 x 45, coat.

Note

- Allen Key SW 6.
- Wrench size SW 16.
- Wrench size SW 24.

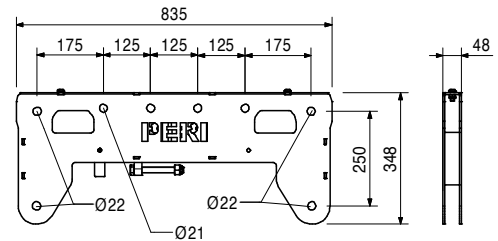
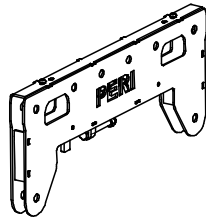

Accessories

104031	0.462	Fitting Pin Ø 21 x 120
018060	0.014	Cotter Pin 4/1, galv.
111567	0.729	Fitting Pin Ø 26 x 120
022230	0.033	Cotter Pin 5/1, galv.

129577	1.470
--------	-------

Cover Mat LPS 41 x 66

Elastic covering for closing gaps between Platforms and Finishing Platforms LPS in the area of Climbing Rails LPS.

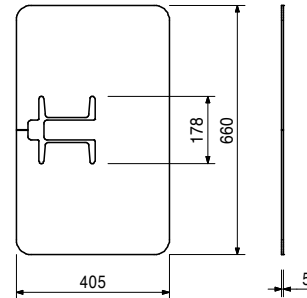
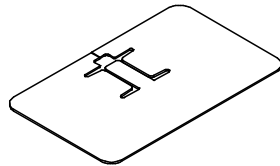

126076	0.998
--------	-------

Cover Strip LPS 20 x 108

Elastic covering for closing gaps between Platforms LPS.

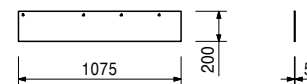
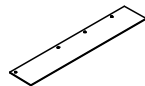

Accessories

125991	0.023	Oval-Head Screw ISO 7380 M10 x 25-10.9, galv
780356	0.011	Nut ISO 7042 M10-8, galv.
125719	0.019	Washer ISO 7094-10 100 HV, galv.

Item no.	Weight kg
126834	1.370

Cover Strip LPS 18 x 158

Elastic covering for closing gaps between Corner Platforms LPS.

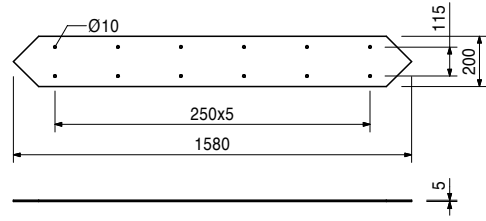
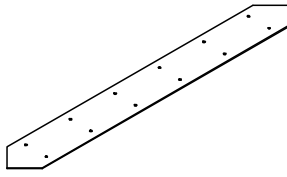

125991	0.023
780356	0.011
125719	0.019

Accessories

- Oval-Head Screw ISO 7380 M10 x 25-10.9, galv**
- Nut ISO 7042 M10-8, galv.**
- Washer ISO 7094-10 100 HV, galv.**

125936	15.500
125937	19.300

- Platform Covers LPS, galv.**
- Platform Cover LPS 50, galv.**
- Platform Cover LPS 62.5, galv.**

Standard platform cover plate, steel.

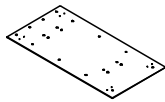

- Note**
- Allen Key SW 6.
- Wrench size SW 16.

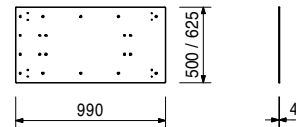

125991	0.023
780356	0.011

Accessories

- Oval-Head Screw ISO 7380 M10 x 25-10.9, galv**
- Nut ISO 7042 M10-8, galv.**

126020	16.300
--------	--------

Platform Cover Bracket LPS/RCS 62.5, galv.

Platform cover plate for fixing over Platform Bracket Multi LPS between RCS rails.

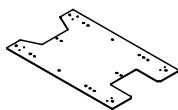

- Note**
- Allen key SW 6.
- Wrench size SW 16.

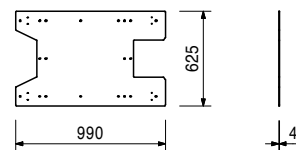

125991	0.023
780356	0.011

Accessories

- Oval-Head Screw ISO 7380 M10 x 25-10.9, galv**
- Nut ISO 7042 M10-8, galv.**

Item no.	Weight kg
117129	10.600
124632	12.800
124634	15.100
117261	21.900

Platform Beams LPS
Platform Beam LPS 235
Platform Beam LPS 285
Platform Beam LPS 335
Platform Beam LPS 485

L
2350
2850
3350
4850

For supporting Platform Coverings LPS.

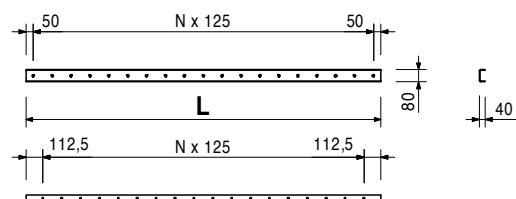
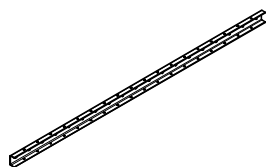

Accessories

710231	0.077
710229	0.033

Bolt ISO 4017 M16 x 30-8.8, galv.
Nut ISO 4032 M16-8, galv.

129480	48.700
129484	52.000
129488	57.300

Telescope Beams Trailing Platforms LPS
Telescope Beam TP LPS 250
Telescope Beam TP LPS 300
Telescope Beam TP LPS 350

L	X	A
2400	1875	920
2900	2375	920
3400	2875	920

For supporting an extendable trailing platform.
 Connection to Climbing Rail LPS or RCS with spacing X. Continuously telescopic on both sides by max. 920 mm, with telescopic screen panel projection A - 30 mm.

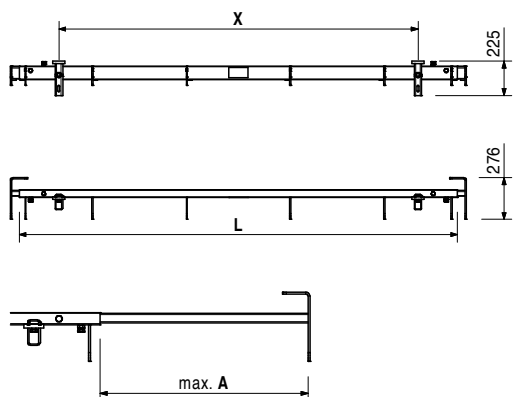
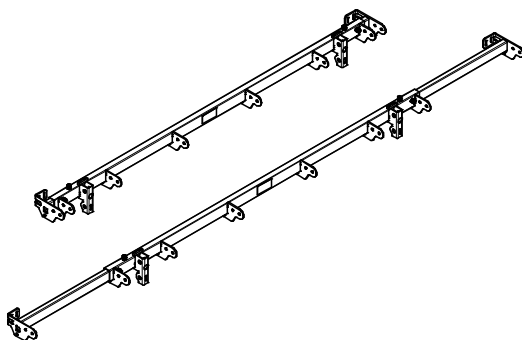

Accessories

104031	0.462
018060	0.014
111567	0.729
022230	0.033
129546	1.420
129573	2.570

Fitting Pin Ø 21 x 120
Cotter Pin 4/1, galv.
Fitting Pin Ø 26 x 120
Cotter Pin 5/1, galv.
Support Angle TP LPS 25
Cantilever TP LPS 57

Item no.	Weight kg
129546	1.420

Support Angle TP LPS 25

Connection of platform covers to Telescope Beam LPS.

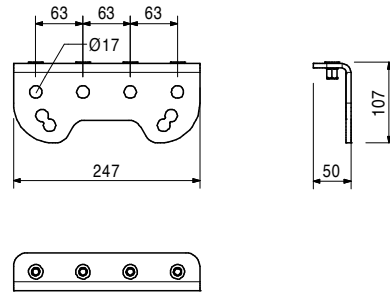
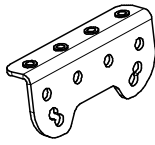

Accessories

113635	0.101
070890	0.030

Bolt ISO 4017 M16 x 40-8.8, galv.
Nut ISO 7040 M16-8, galv.

129573	2.570
--------	-------

Cantilever TP LPS 57

For supporting wide Trailing Platform made of plywood in combination with Support Angle TP LPS 25.

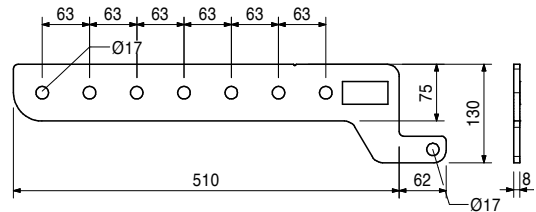
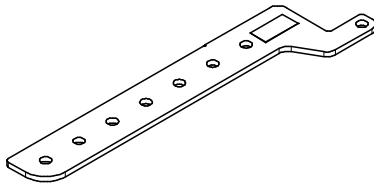

Accessories

113635	0.101
070890	0.030
118123	0.055
018060	0.014

Bolt ISO 4017 M16 x 40-8.8, galv.
Nut ISO 7040 M16-8, galv.
Pin Ø 16 x 36, galv.
Cotter Pin 4/1, galv.

LPS Light Climbing System



Item no.	Weight kg
129517	16.500
129521	22.100
129525	27.600

Platform Covers Trailing Platforms LPS
Platform Cover TP LPS 250
Platform Cover TP LPS 300
Platform Cover TP LPS 350

As platform cover on fixed middle section of Telescope Beam Trailing Platform LPS of length X. Connection to Support Angles TP LPS 25.

L	X
1500	2500
2000	3000
2500	3500

Note

Complete with:
 125991 Oval-Head Screw ISO 7380 M10 x 25-10.9, galv.
 780356 Nut ISO 7042 M10-8, galv.
 128306 Washer ISO 7093-10 200 HV, galv.

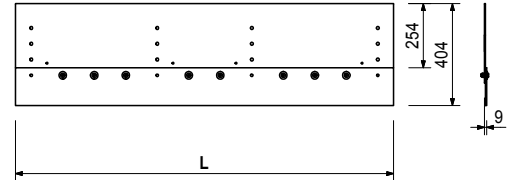
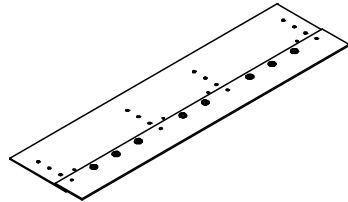

Accessories

129546	1.420
125991	0.023

Support Angle TP LPS 25
Oval-Head Screw ISO 7380 M10 x 25-10.9, galv

129530	14.900
--------	--------

Platform Cover TP LPS 92
 Platform cover on telescopes to the left and right of Telescope Beams Trailing Platform LPS. Telescopic range fixed A= 830 mm. Connection to Support Angles TP LPS 25.

Complete with

9 pc. 125991 Oval-Head Screw ISO 7380 M10 x 25-10.9, galv
 9 pc. 780356 Nut ISO 7042 M10-8, galv.
 9 pc. 128306 Washer ISO 7093-10 200 HV, galv.

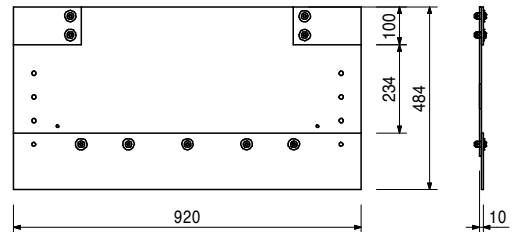
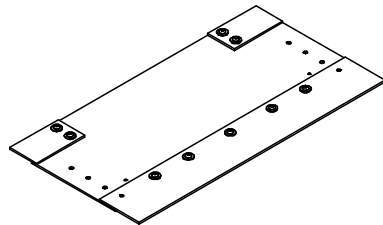

Accessories

129546	1.420
125991	0.023

Support Angle TP LPS 25
Oval-Head Screw ISO 7380 M10 x 25-10.9, galv

Item no.	Weight kg
129536	4.730

Corner Cover TP LPS, right

As platform cover on telescopes to the right of Telescope Beam Trailing Platform LPS, for forming mitred corners at right-angled building corners.

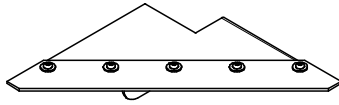

Complete with

5 pc. 125991 Oval-Head Screw ISO 7380 M10 x 25-10.9, galv
 5 pc. 780356 Nut ISO 7042 M10-8, galv.
 5 pc. 128306 Washer ISO 7093-10 200 HV, galv.

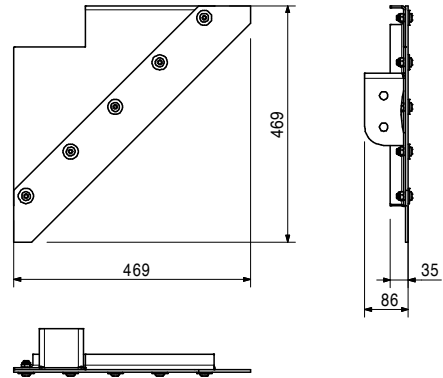

Accessories

113635	0.101
070890	0.030

Bolt ISO 4017 M16 x 40-8.8, galv.

Nut ISO 7040 M16-8, galv.

129547	4.730
--------	-------

Corner Cover TP LPS, left

As platform cover on telescopes to the left of Telescope Beam Trailing Platform LPS, for forming mitred corners at right-angled building corners.

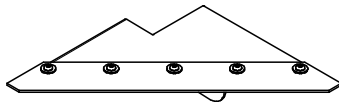

Complete with

5 pc. 125991 Oval-Head Screw ISO 7380 M10 x 25-10.9, galv
 5 pc. 780356 Nut ISO 7042 M10-8, galv.
 5 pc. 128306 Washer ISO 7093-10 200 HV, galv.

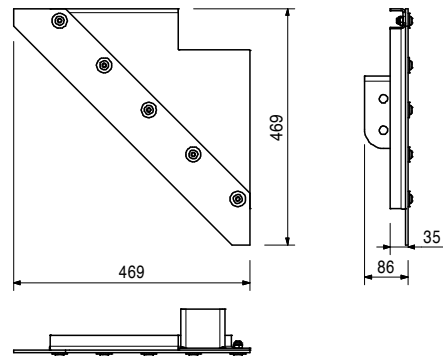

Accessories

113635	0.101
070890	0.030

Bolt ISO 4017 M16 x 40-8.8, galv.

Nut ISO 7040 M16-8, galv.

LPS Light Climbing System

Item no.	Weight kg
129570	6.880

Bracing Chain LPS 5.0 m
For stiffening protection panel unit with lateral wind load.

Complete with
2 pc. 129567 Shackles Bolt Pin Ø12
1 pc. 129569 Turnbuckle DIN 1480 H/OE M14
1 pc. 129568 Snap Hook DIN 5299-C80-ZN

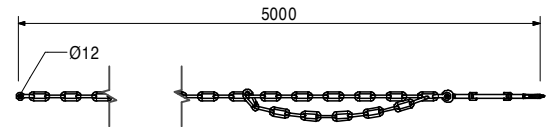
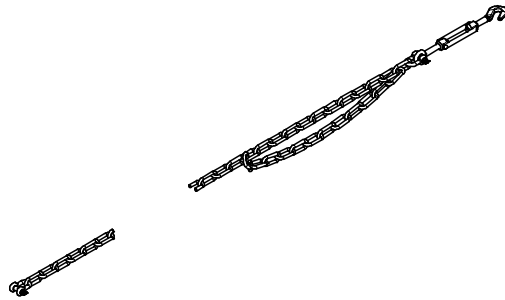

Accessories
Bracing Connector LPS

129814	0.309
--------	-------

Bracing Connector LPS
For the connection of Bracing Chain to Climbing Rail LPS.

Complete with
1 pc. 128991 Linchpin DIN 11023-5x32, galv.

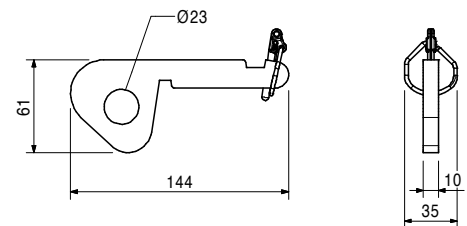
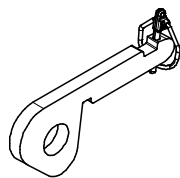

123478	0.255
--------	-------

Toe Board Angle 90°
For diverse timber connections.

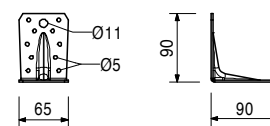

Accessories
Spax Screw TX 30 8 x 20, yellow galv.
Spax Screw TX 25, 6 x 20, yellow galv.

024550	0.005
129711	0.010

Pin Ø 16 x 36, galv.

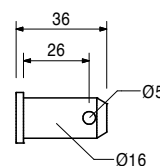
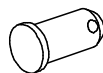

Item no.	Weight kg	
018060	0.014	Cotter Pin 4/1, galv.

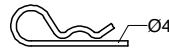

			L
711078	0.360	Bolts ISO 4014 M20	130
710226	0.340	Bolt ISO 4014 M20 x 130-8.8, galv.	90
		Bolt ISO 4014 M20 x 90-8.8, galv.	

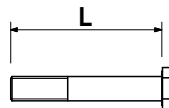
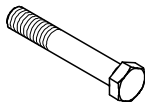

781053	0.065	Nut ISO 7040 M20-8, galv. Self-locking.
--------	-------	---

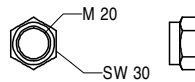

113635	0.101	Bolt ISO 4017 M16 x 40-8.8, galv.
--------	-------	--

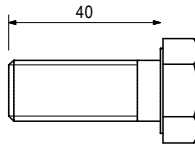
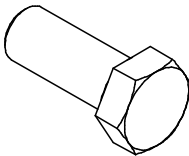

710229	0.033	Nut ISO 4032 M16-8, galv.
--------	-------	----------------------------------

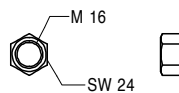

LPS Light Climbing System

Item no.	Weight kg		
		Oval-Head Screws ISO 7380 M10	L
125991	0.023	Oval-Head Screw ISO 7380 M10 x 25-10.9, galv	25
129571	0.033	Oval-Head Screw ISO 7380 M10 x 40-10.9, galv	40

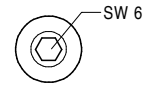
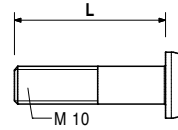
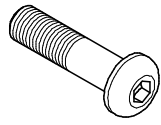

125719	0.019	Washer ISO 7094-10 100 HV, galv.	
--------	-------	---	--

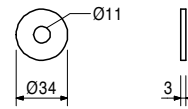

780356	0.011	Nut ISO 7042 M10-8, galv. Self-locking.	Note Wrench size SW 16, 24, 36.
--------	-------	---	---



024520	0.052	Lag Screw DIN 571 8 x 160, galv.	
--------	-------	---	--

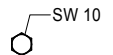
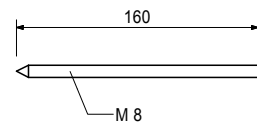
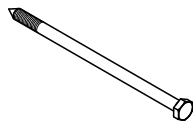

		F.H. Bolts DIN 603 M8, galv.	L	B
710295	0.028	F.H. Bolt DIN 603 M8 x 45 MU, galv.	45	22
710240	0.050	F.H. Bolt DIN 603 M8 x 100 MU, galv.	100	80

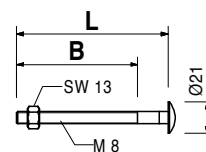
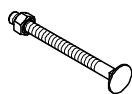

Item no. Weight kg

113347 0.013 Washer ISO 7094 100 HV, A 8, galv.

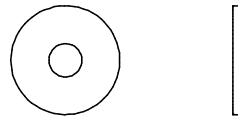
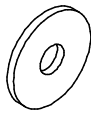

110642 0.006 Spax Screw TX25, 5 x 40, yellow galv.

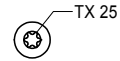
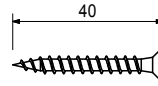
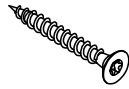

125458 0.271 Flap Safety Plate LPS Ø 48
For safety flap up-lift protection.

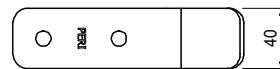
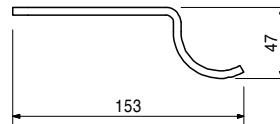
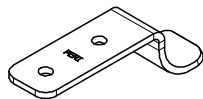

Accessories

024550 0.005 Spax Screw TX 30 8 x 20, yellow galv.

129711 0.010 Spax Screw TX 25, 6 x 20, yellow galv.

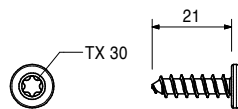

LPS Light Climbing System



Item no.	Weight kg
125461	0.711

Flap Hinge LPS Ø 48/M10
 For mounting safety flap on Scaffold Tubes
 Ø 48.3 x 3.2.

Complete with
 2 pc. 710335 Bolt ISO 4014 M10 x 50-8.8, galv.
 2 pc. 125719 Washer ISO 7094-10 100 HV, galv.

Note
 Wrench size SW 16.

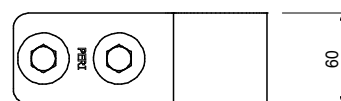
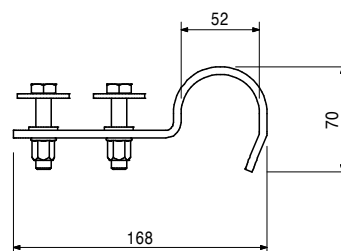
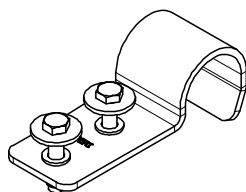

125976	8.900
026413	10.650
114287	12.500
026419	17.750

Scaffold Tubes Steel Ø 48.3 x 3.2
Scaff. Tube Steel Ø 48.3 x 3.2, l = 2.5 m
Scaff. Tube Steel Ø 48.3 x 3.2, l = 3.0 m
Scaff. Tube Steel Ø 48.3 x 3.2, l = 3.5 m
Scaff. Tube Steel Ø 48.3 x 3.2, l = 5.0 m

L
 2500
 3000
 3500
 5000

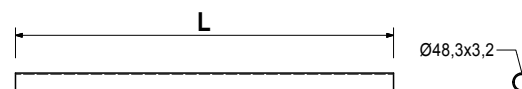
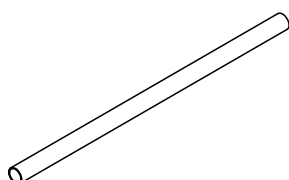

125972	6.070
--------	-------

Telescopic Scaffold Tube LPS
 For telescopic extension of safety flap scaffold tube.

Complete with
 2 pc. 710335 Bolt ISO 4014 M10 x 50-8.8, galv.
Note
 Wrench size SW 16.

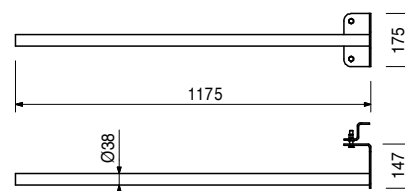
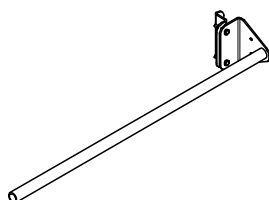

Item no.	Weight kg
128317	0.283

Scaffold Tube Connector Ø 48-M10 LPS
For assembly of Scaffold Tubes Ø 48 to Climbing Rails LPS.

Complete with
1 pc. 118533 Bolt ISO 4017 M10x030-8.8, galv

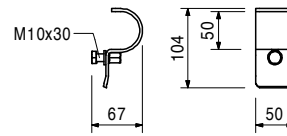

110296	0.220
--------	-------

Clamp A64 DIN 3570 M12, galv.
For assembling Scaffold Tubes Ø 48 or Ø 60.

Note
Wrench size SW 19.

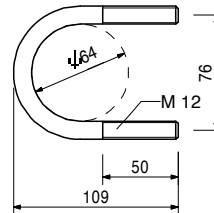
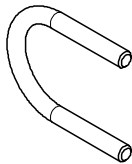

Accessories

710330	0.017
--------	-------

Nut ISO 4032 M12-8, galv.

710330	0.017
--------	-------

Nut ISO 4032 M12-8, galv.

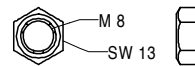

125856	2.580
--------	-------

Scaffold Tube Adapter LPS/RCS Ø 48
For assembling Scaffold Tubes Ø 48 to Climbing Rail RCS.

Complete with
1 pc. 017040 Screw-On Coupler AK 48, galv.
1 pc. 710894 Pin Ø 25 x 180, geomet.
2 pc. 018060 Cotter Pin 4/1, galv.

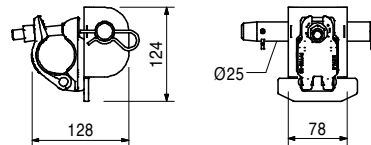
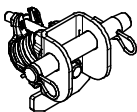

125960	2.190
--------	-------

Cover Mat LPS 60 x 75, U120 – 140
Elastic covering for safety flaps. Seals area around Climbing Rail LPS.

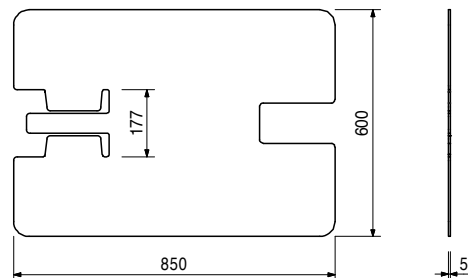
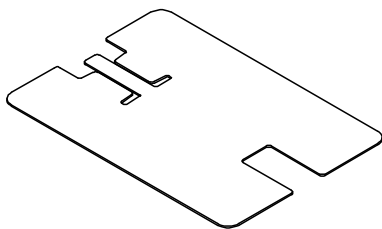

LPS Light Climbing System

Item no.	Weight kg
111436	0.150

Hinge DIN 7957-200-ST, yellow galv.
For mounting the cover flap on the climbing protection panel.

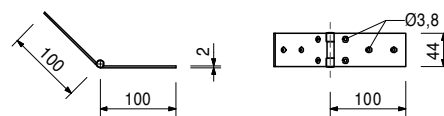
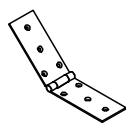

Accessories

111437	0.004
110642	0.006

Spax Screw TX25, 5 x 20, yellow galv.
Spax Screw TX25, 5 x 40, yellow galv.

052828	9.350
052800	10.400

Raw Plywood 20, 21 mm
FinNa-Ply 21 mm 2500 x 1250 mm
Conifer Plywood 20 mm 2500 x 1250 mm
High-grade shuttering plywood.

Note

5 to 7 veneers. Sanded surface of Nordic coniferous wood and partially sealed on one side.

Weight kg = kg/m²

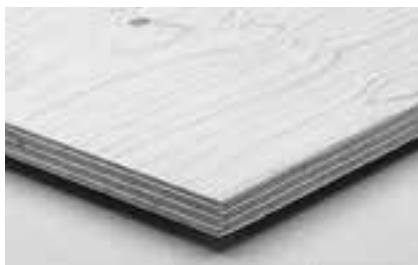

129576	0.450
--------	-------

Fixation Chain TP LPS 58
For fixing a folded up safety flap or trailing platform to Climbing Rail LPS.

Complete with

2 pc. 129575 Snap Hook DIN 5299-C90-ZN

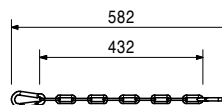

Item no.	Weight kg
128799	15.000

Rail Guidance Shoe-2 LPS

Anchor system M24. Guide and support for Climbing Rail LPS when fixed at the wall. With foldable guide runners and spring-loaded pawl.

Complete with

- 2 pc. 123867 Threaded Bolt Shera LPS DW 15
- 1 pc. 781053 Nut ISO 7040 M20-8, galv.
- 3 pc. 070890 Nut ISO 7040 M16-8, galv.
- 2 pc. 710219 Bolt ISO 4014 M16 x 100-8.8, galv.
- 1 pc. 128604 Bolt ISO 4014 M16 x 110-10.9, galv.
- 1 pc. 128605 Bolt ISO 1014 M20 x 110-10.9, galv.

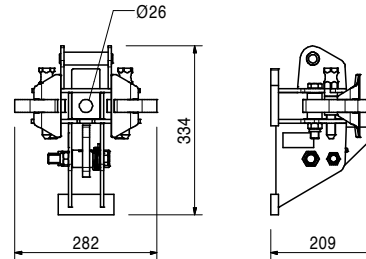
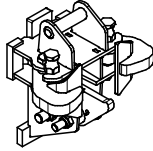

Accessories

026430	0.334
--------	-------

Bolt ISO 4014 M24 x 70-10.9, galv.

128562	36.100
--------	--------

Slab Shoe-2 LPS, adjustable

Anchor system M24. With integrated rail guiding and height-adjustable support for Climbing Rails LPS. With adjustable cantilever over the slab edge.

Complete with

- 2 pc. 123867 Threaded Bolt Shera LPS DW 15
- 5 pc. 781053 Nut ISO 7040 M20-8, galv.
- 2 pc. 710219 Bolt ISO 4014 M16 x 100-8.8, galv.
- 3 pc. 070890 Nut ISO 7040 M16-8, galv.
- 1 pc. 711078 Bolt ISO 4014 M20 x 130-8.8, galv.
- 1 pc. 128604 Bolt ISO 4014 M16 x 110-10.9, galv.
- 4 pc. 128605 Bolt ISO 1014 M20 x 110-10.9, galv.

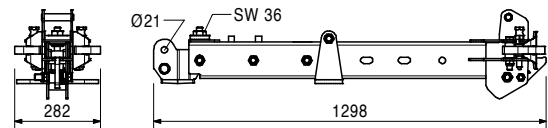
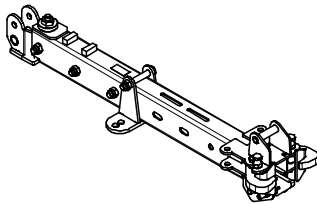

Accessories

026430	0.334
124777	0.210

Bolt ISO 4014 M24 x 70-10.9, galv.

Anchor Bolt PERI 14/20 x 130

128883	45.600
--------	--------

Slab Shoe Corner-2 LPS

Anchor system M24. With integrated Rail Guidance Shoe-2 LPS and support for Climbing Rail LPS at building corners. Rail Guidance Shoe-2 LPS removable.

Complete with

- 1 pc. 128799 Rail Guidance Shoe-2 LPS
- 2 pc. 123867 Threaded Bolt Shera LPS DW 15
- 1 pc. 105032 Nut ISO 7042 M24-8, galv.
- 1 pc. 125462 Bolt ISO 4017 M24 x 60-8.8, galv.
- 2 pc. 117452 Bolt ISO 4014 M20 x 130-10.9
- 2 pc. 781053 Nut ISO 7040 M20-8, galv.

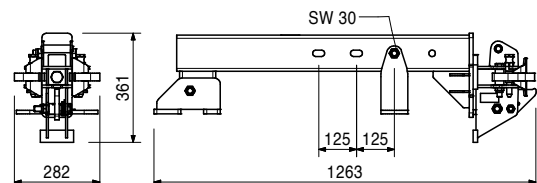
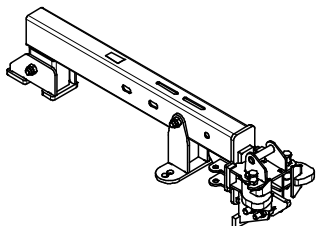

Accessories

026430	0.334
124777	0.210

Bolt ISO 4014 M24 x 70-10.9, galv.

Anchor Bolt PERI 14/20 x 130

LPS Light Climbing System

Item no.	Weight kg
031220	1.010

Climbing Cone-2 M24/DW 15, galv.
Anchor system M24.
For anchoring climbing systems.

Note
Separate design information on request.

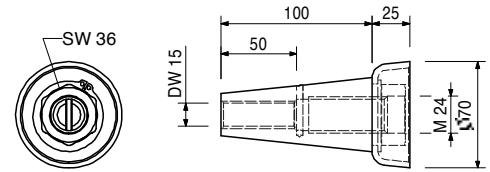
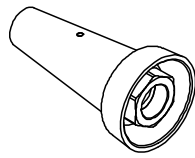

030840	0.515
030030	1.440
030740	1.550

Accessories
Threaded Anchor Plate DW 15
Tie Rod DW 15, spec. length
Tie Rod B 15, spec. length

030840	0.515
--------	-------

Threaded Anchor Plate DW 15
For use with Tie Rod DW 15 or B 15. For anchoring in concrete.

Note
Lost anchor part.

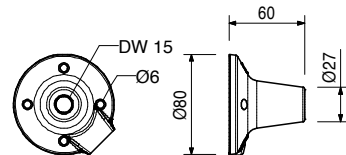
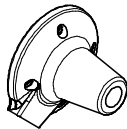

030030	1.440
030050	0.000

Tie Rod DW 15
Tie Rod DW 15, spec. length
Cutting Cost Tie Rod DW 15, B 15

Note
Non-weldable! Take official Approval into consideration!
Technical Data
Permissible tension force 90 kN.

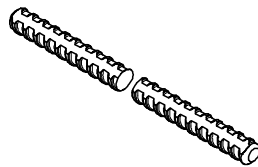

030740	1.550
030050	0.000

Tie Rod B 15
Tie Rod B 15, spec. length
Cutting Cost Tie Rod DW 15, B 15

Note
Weldable! Take official Approval into consideration!
Technical Data
Permissible tension force 82 kN.

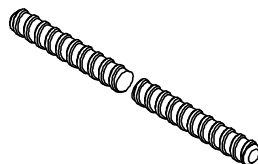

Item no.	Weight kg
114158	1.030

Screw-On Cone-2 M24/DW 20, galv.
Anchor system M24.
For anchoring climbing systems.

Note
Separate design information on request.

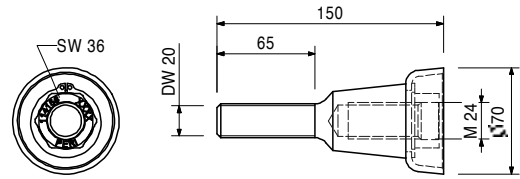
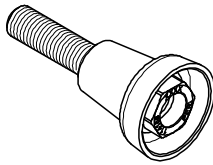

Accessories

030860	0.792
--------	-------

Threaded Anchor Plate DW 20

030860	0.792
--------	-------

Threaded Anchor Plate DW 20
For use with Tie Rod DW 20, B 20 or Screw-On Cone-2 M24/DW 20. For anchoring in concrete.

Note
Lost anchor part.

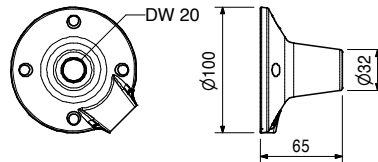
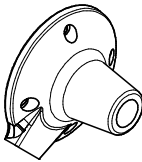

026430	0.334
--------	-------

Bolt ISO 4014 M24 x 70-10.9, galv.
High-strength bolt for anchoring climbing systems.

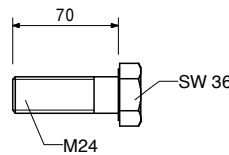
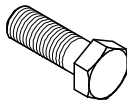

029270	0.331
--------	-------

Advancing Bolt M24, galv.
For fixing the M24 anchor system if the plywood formlining is drilled through.

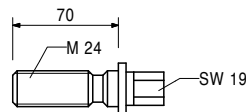
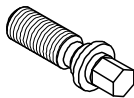

Accessories

029280	0.196
--------	-------

Anchor Positioning Plate M24, galv.

124777	0.210
--------	-------

Anchor Bolt PERI 14/20 x 130
For temporary fixing to reinforced concrete structures.

Note
See PERI Data Sheet!
Drilling Ø 14 mm.

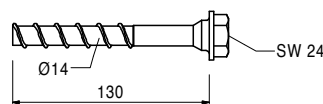
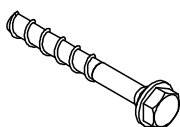

Item no.	Weight kg
127347	13.500

Slab Anchor Template-2 LPS

Anchor system M24.
For positioning the Advancing Bolt M24 for the Slab Shoe LPS.

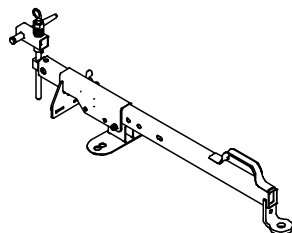

Complete with

1 pc. 104031 Fitting Pin \varnothing 21 x 120
1 pc. 022230 Cotter Pin 5/1, galv.

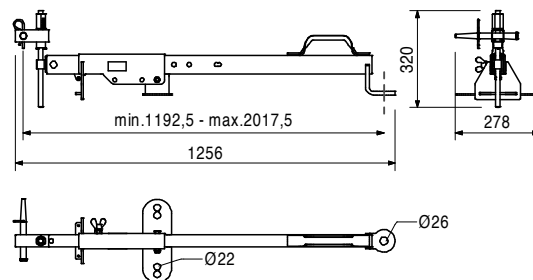

Item no.	Weight kg
029270	0.331

Accessories

Advancing Bolt M24, galv.

Item no.	Weight kg
114317	3.210

Guide in Tool RCS

For pulling up the Climbing Rail RCS in order to close the folding runners of the Climbing Shoe.

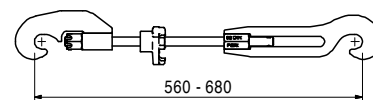
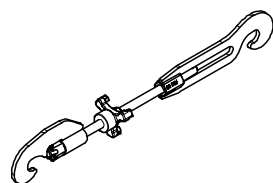

Item no.	Weight kg
125815	25.000

Climbing Device LPS 30 kN

For crane-independent climbing of LPS Climbing Units.

Complete with

1 pc. 125632 Protect. Covers Climb. Device RCS

Note

Follow Instructions for Use.
Permissible load-bearing capacity 30 kN.

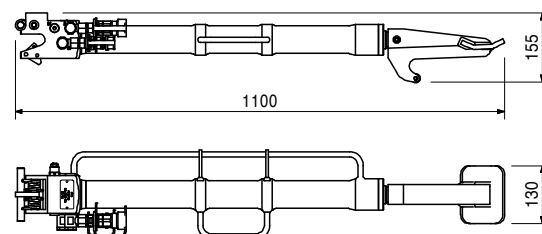
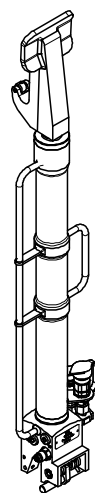

LPS Light Climbing System



Item no.	Weight kg
109766	109.000

Hydraulic Pump RCS 4-fold, 380 – 460 V
 Hydraulic pump for actuating the Climbing Device RCS 50 and LPS 30.

Note
 Follow Instructions for Use.
 Use only original PERI Hydraulic Oil HV LP46.

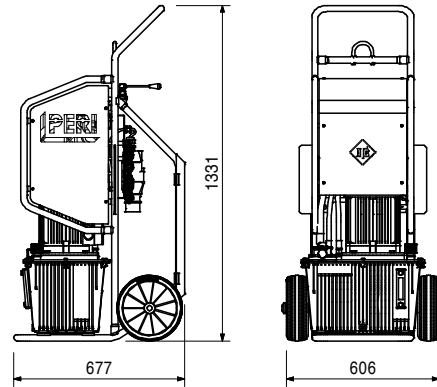
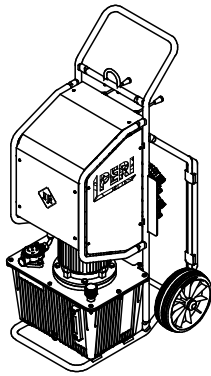

Accessories

057376	18.300
--------	--------

Hydraulic Oil ISO 11158 HVI46, 20 l

Hydraulic Fluids	
131270	17.900
131274	18.300
057376	18.300

Hydraulic Oil ISO 11158 HM10, 20 l
Hydraulic Oil ISO 11158 HVI22, 20 l
Hydraulic Oil ISO 11158 HVI46, 20 l

High-quality synthetic hydraulic oils for PERI Hydraulic Pumps with different viscosity suitable for certain temperature ranges.

Technical Data

Observe Safety Data Sheet and applicable National Safety Regulations regarding hydraulic oil, in particular for transport, storage and disposal! Observe the technical documentation for the hydraulic pump! Product Data Sheet on request.

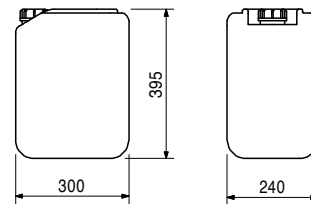

110069	8.500
110070	15.300

Hydraulic Twin Hoses RCS
Hydraulic Twin Hose RCS, 10 m
Hydraulic Twin Hose RCS, 20 m

For connecting Hydraulic Pump RCS to the Climbing Device RCS 50 and LPS 30. With quick-release connectors.

Complete with

2 pc. 110822 Quick Coupler Bushing RCS
 2 pc. 110823 Quick Coupler Nipple RCS

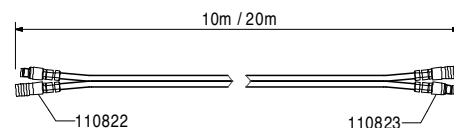
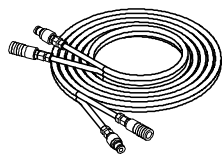

Item no.	Weight kg
110280	0.500

Adapter Cable RCS

For the power supply to the Hydraulic Pump RCS.

Note

Follow Instructions for Use!
With CEE plug connector 400 V 16 A.

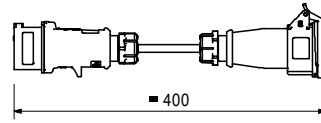
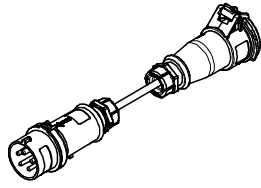

110279	0.250
--------	-------

Plug Socket RCS, black

For providing the power supply to the Hydraulic Pump RCS with 380 – 460 V, 50 – 60 Hz.

Note

Follow Instructions for Use!

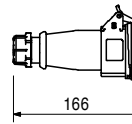

125632	0.050
--------	-------

Protect. Covers Climb. Device RCS

Spare part. To protect the quick couplers against dirt and damage.

Technical Data

1 set for 1 Climbing Device RCS 50 (2x bushing and 2x nipple each).

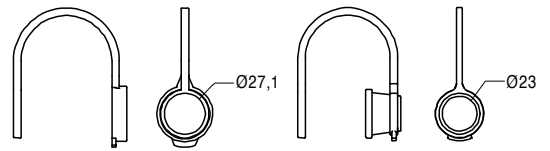
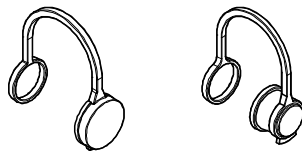

127834	2.210
--------	-------

Crane Eye BR-2 2.5 t, galv.

As attachment point for moving climbing systems or Platform Beam BR.

Note

Follow Instructions for Use!

Technical Data

Permissible load-bearing capacity 2.5 t.

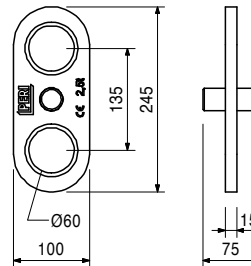

Accessories

020620	0.561
--------	-------

Spacer for Platform Beam BR

Item no.	Weight kg
127320	163.000

Lifting Beam 10 t
For moving climbing units.

Complete with

- 1 pc. 112865 Bolt 25 x 180
- 1 pc. 022230 Cotter Pin 5/1, galv.
- 1 pc. 107297 Bolt ISO4014-M12 x 140-8.8, galv.
- 1 pc. 710330 Nut ISO 4032 M12-8, galv.

Note

Follow Instructions for Use.

Technical Data

Permissible load-bearing capacity 10 t.

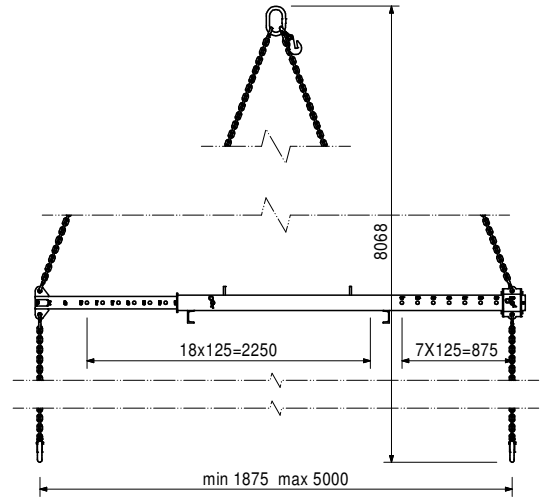
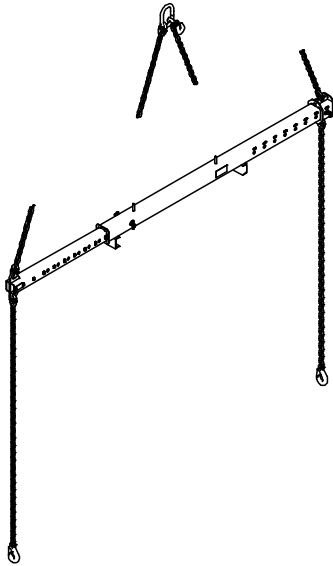

072180	0.560
051764	2.650
029610	5.300

Ratchet Wrenches
Ratchet Wrench 1/2"
Ratchet Wrench 3/4"
Ratchet Wrench 1"

L

- 300
- 630
- 900

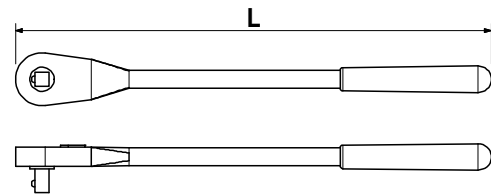
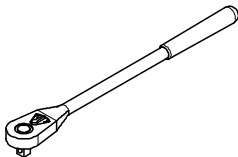

126233	0.060
029620	0.075
051766	0.215
057276	0.625
102785	0.452
029630	0.580

Sockets SW
Socket SW 16-1/2"
Socket SW 19-1/2"
Socket SW 24-3/4"
Socket SW 30-3/4"
Socket SW 36-3/4"
Socket SW 46-1"



Item no.	Weight kg		Note
057278	0.405	Allen Key Set, 8 pcs.	Sizes: 2; 2.5; 3; 4; 5; 6; 8; 10.

026230	1.010	Anchor Sleeve M24 To anchor platform systems.	Note Separate design information on request.
--------	-------	---	--

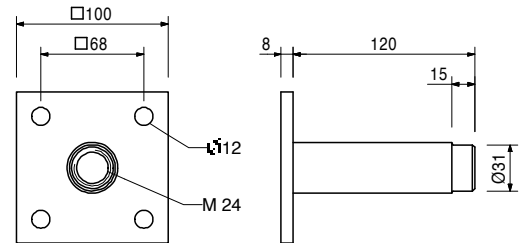
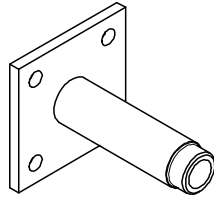

Accessories

026240	0.026	Cone PP Ø 31/26, c = 25
026250	0.005	Plug Ø 26 mm
116233	0.116	Cone FRC Ø 32/52, c = 40
026420	0.123	Anchor Positioning Stud M24, galv.
116234	0.033	Plug FRC Ø = 32
115150	0.200	Anchor Positioning Stud M24 x 65, galv.
123800	0.045	Metric Threaded Cone M24

026250	0.005	Plug Ø 26 mm For closing Cone PP Ø 31 for Anchor Sleeve M24. Made of polypropylene.
--------	-------	--

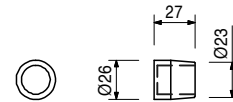

070890	0.030	Nut ISO 7040 M16-8, galv. Self-locking.
--------	-------	---

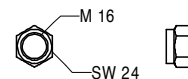

710330	0.017	Nut ISO 4032 M12-8, galv.
--------	-------	----------------------------------

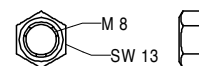

Item no.	Weight kg	
105402	0.200	Bolt ISO 4014 M16 x 120-8.8, galv.

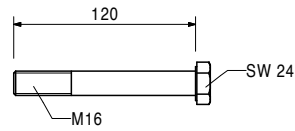
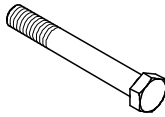

710262	0.007	Screw ISO 15482 5.5 x 45 TX 30, galv.
--------	-------	--

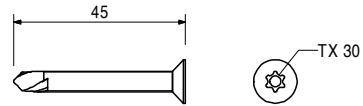
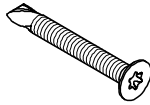

105847	0.005	Spax 5 x 25 SK-cross recess, galv.
--------	-------	---

024470	0.008	TSS-Torx 6 x 60, galv. For Torx Blade TX 30. Self-drilling.
--------	-------	---

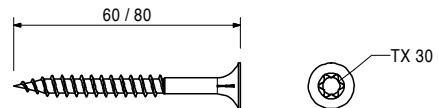
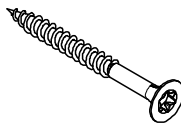

710231	0.077	Bolt ISO 4017 M16 x 30-8.8, galv. With a continuous thread.
--------	-------	---

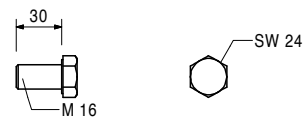

031652	0.247	KK Concrete Cone M24-67/52 For closing anchor points with Climbing Cone-2, M24/DW 15 and Screw-On Cone-2 M24/DW 20.	Note Delivery unit 50 pieces.
--------	-------	---	---

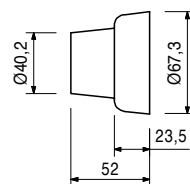
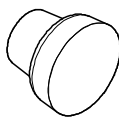

131709	9.980	Accessories Sealing Compound-3, 6-can set
--------	-------	---

Item no.	Weight kg
065027	0.359

Spacer Tube rough DR 22, l = 2.00 m
 Plastic Spacer Tube for DW 15, B 15.

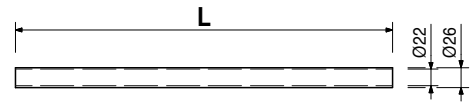
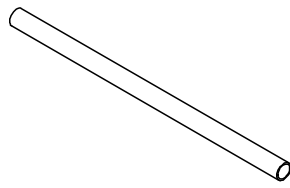

026240	0.026
--------	-------

Cone PP Ø 31/26, c = 25
 Resulting in a concrete cover of 25 mm in combination with Anchor Sleeve M24. Made of polypropylene.

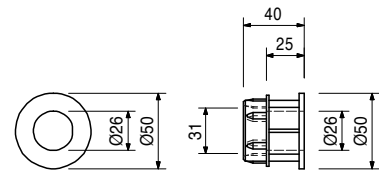

PERI International

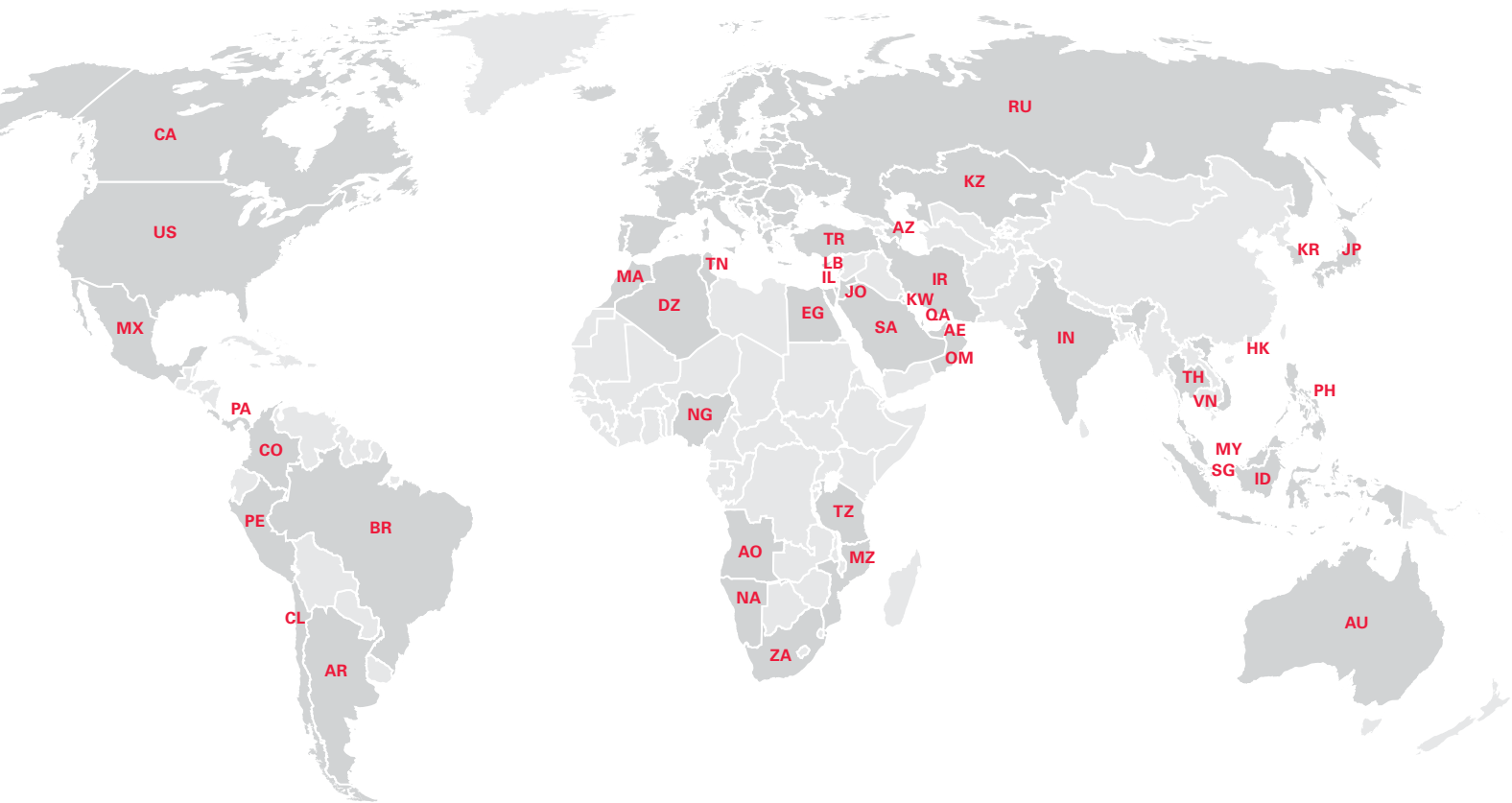

North America

- CA** Canada
PERI Formwork Systems, Inc.
www.peri.ca
- MX** Mexico
PERI Cimbras y Andamios, S.A. de C.V.
www.peri.com.mx
- PA** Panama
PERI Panama Inc.
www.peri.com.pa
- US** USA
PERI Formwork Systems, Inc.
www.peri-usa.com

South America

- AR** Argentina
PERI S.A.
www.peri.com.ar
- BR** Brazil
PERI Formas e Escoramentos Ltda.
www.peribrasil.com.br
- CL** Chile
PERI Chile Ltda.
www.peri.cl
- CO** Colombia
PERI S.A.S.
www.peri.com.co
- PE** Peru
PERI Peruana S.A.C.
www.peri.com.pe

Africa

- AO** Angola
Pericofragens, Lda.
www.peri.pt
- DZ** Algeria
S.A.R.L. PERI
www.peri.dz
- EG** Egypt
Egypt Branch Office
www.peri.com.eg
- MA** Morocco
PERI S.A.
www.peri.ma
- MZ** Mozambique
PERI (Pty.) Ltd.
www.peri.co.mz
- NA** Namibia
PERI (Pty.) Ltd.
www.peri.na
- NG** Nigeria
PERI Nigeria Ltd.
www.peri.ng
- TN** Tunisia
PERI S.A.U.
www.peri.es
- TZ** Tanzania
PERI Formwork and Scaffolding Ltd
www.peri.co.tz
- ZA** South Africa
PERI Formwork Scaffolding (Pty) Ltd
www.peri.co.za

Asia

- AE** United Arab Emirates
PERI (L.L.C.)
www.peri.ae
- AZ** Azerbaijan
PERI Representative Office
www.peri.com.tr
- HK** Hong Kong
PERI (Hong Kong) Limited
www.perihk.com
- ID** Indonesia
PT Beton Perkasa Wijaksana
www.betonperkasa.com
- IL** Israel
PERI F.E. Ltd.
www.peri.co.il
- IN** India
PERI (India) Pvt Ltd
www.peri.in
- IR** Iran
PERI Pars. Ltd.
www.peri.ir
- JO** Jordan
PERI GmbH – Jordan
www.peri.com
- JP** Japan
PERI Japan K.K.
www.peri.co.jp
- KR** Korea
PERI (Korea) Ltd.
www.perikorea.com
- KW** Kuwait
PERI Kuwait W.L.L.
www.peri.com.kw
- KZ** Kazakhstan
TOO PERI Kazakhstan
www.peri.kz
- LB** Lebanon
PERI Lebanon Sarl
lebanon@peri.de
- MY** Malaysia
PERI Formwork Malaysia Sdn. Bhd.
www.perimalaysia.com
- OM** Oman
PERI (L.L.C.)
www.peri.ae
- PH** Philippines
PERI-Asia Philippines, INC.
www.peri.com.ph
- QA** Qatar
PERI Qatar LLC
www.peri.qa
- SA** Saudi Arabia
PERI Saudi Arabia Ltd.
www.peri.com.sa
- SG** Singapore
PERI Asia Pte Ltd
www.periasia.com
- TH** Thailand
Peri (Thailand) Co., Ltd.
www.peri.co.th
- TR** Turkey
PERI Kalıp ve İskeleleri
www.peri.com.tr
- VN** Vietnam
PERI ASIA PTE LTD
www.peri.com.vn



PERI

**PERI GmbH
Formwork Scaffolding Engineering**

Rudolf-Diesel-Strasse 19
89264 Weissenhorn
Germany
Tel. +49 (0)7309.950-0
Fax +49 (0)7309.951-0
info@peri.com
www.peri.com

Oceania

AU Australia
PERI Australia Pty. Ltd.
www.periaus.com.au

DK Denmark
PERI Danmark A/S
www.peri.dk

IT Italy
PERI S.r.l.
www.peri.it

SE Sweden
PERI Sverige AB
www.peri.se

Europe

EE Estonia
PERI AS
www.peri.ee

LT Lithuania
PERI UAB
www.peri.lt

SI Slovenia
PERI oplate i skele d.o.o
www.peri.com.hr

AL Albania
PERI Kalıp ve İskeleleri
www.peri.com.tr

ES Spain
PERI S.A.U.
www.peri.es

LU Luxembourg
N.V. PERI S.A.
www.peri.lu

SK Slovakia
PERI spol. s. r.o.
www.peri.sk

AT Austria
PERI Ges.mbh
www.peri.at

FI Finland
PERI Suomi Ltd. Oy
www.perisuomi.fi

LV Latvia
PERI SIA
www.peri-latvija.lv

UA Ukraine
TOW PERI
www.peri.ua

BA Bosnia and Herzegovina
PERI oplate i skele d.o.o
www.peri.com.hr

FR France
PERI S.A.S.
www.peri.fr

NL Netherlands
PERI b.v.
www.peri.nl

BE Belgium
PERI N.V.
www.peri.be

GB United Kingdom
PERI Ltd.
www.peri.ltd.uk

NO Norway
PERI Norge AS
www.peri.no

BG Bulgaria
PERI Bulgaria EOOD
www.peri.bg

GR Greece
PERI Hellas Ltd.
www.perihellas.gr

PL Poland
PERI Polska Sp. z o.o.
www.peri.com.pl

BY Belorussia
IOOO PERI
www.peri.by

HR Croatia
PERI oplate i skele d.o.o.
www.peri.com.hr

PT Portugal
Pericofragens Lda.
www.peri.pt

CH Switzerland
PERI AG
www.peri.ch

HU Hungary
PERI Kft.
www.peri.hu

RO Romania
PERI România SRL
www.peri.ro

CZ Czech Republic
PERI spol. s r.o.
www.peri.cz

IR Ireland
Siteserv Access & Formwork
www.siteservaccess.ie

RS Serbia
PERI oplate d.o.o.
www.peri.rs

DE Germany
PERI GmbH
www.peri.de

IS Iceland
Armar ehf.
www.armor.is

RU Russia
OOO PERI
www.peri.ru

**The optimal System
for every Project and
every Requirement**



Wall Formwork



Column Formwork



Slab Formwork



Climbing Systems



Bridge Formwork



Tunnel Formwork



Shoring Systems



Construction Scaffold



Facade Scaffold



Industrial Scaffold



Access



Protection Scaffold



Safety Systems



System-Independent Accessories



Services



PERI GmbH
Formwork Scaffolding Engineering
 Rudolf-Diesel-Strasse 19
 89264 Weissenhorn
 Germany
 Tel. +49 (0)7309.950-0
 Fax +49 (0)7309.951-0
 info@peri.com
 www.peri.com

