

MULTIPROP MP 120, 250, 350, 480, 625

Slab Props

Instructions for Assembly and Use – Standard Configuration – Version 2.0 AU 01.2022



Overview	
Main components	3
Key	4
Introduction	
Target groups	5
Additional technical documentation	5
Intended use	6
Instructions for Use	6
Cleaning and maintenance instructions	7
Safety instructions	
Cross-system	8
System-specific	9
Standard configuration	
A1 Assembly	10
Pre-assembling the slab prop	10
Assembly with the universal tripod	12
A2 Dismantling	13
Releasing the slab prop under load	13
A3 Accessories	14
Brace clamp	14
Base MP 50	15
A4 Foreseeable misapplications	16
A5 Storage and transportation	20
Storage	21
Transportation	21
Design Tables: Permissible prop loads	
MULTIPROP 120, 250, 350	22
MULTIPROP 480, 625	23
MULTIPROP 120, 250, 350 with Base MP 50	24
MULTIPROP 480, 625 with Base MP 50	25
Product Catalogue	
MULTIPROP Slab Props	26

Main components

MULTIPROP MP

- 1 Outer tube
- 2 Inner tube
- 3 Safety hook
- 4 Adjusting nut
- 5 Compression spring
- 6 Measuring scale
- 7 Rubbing plate
- 8 End plate

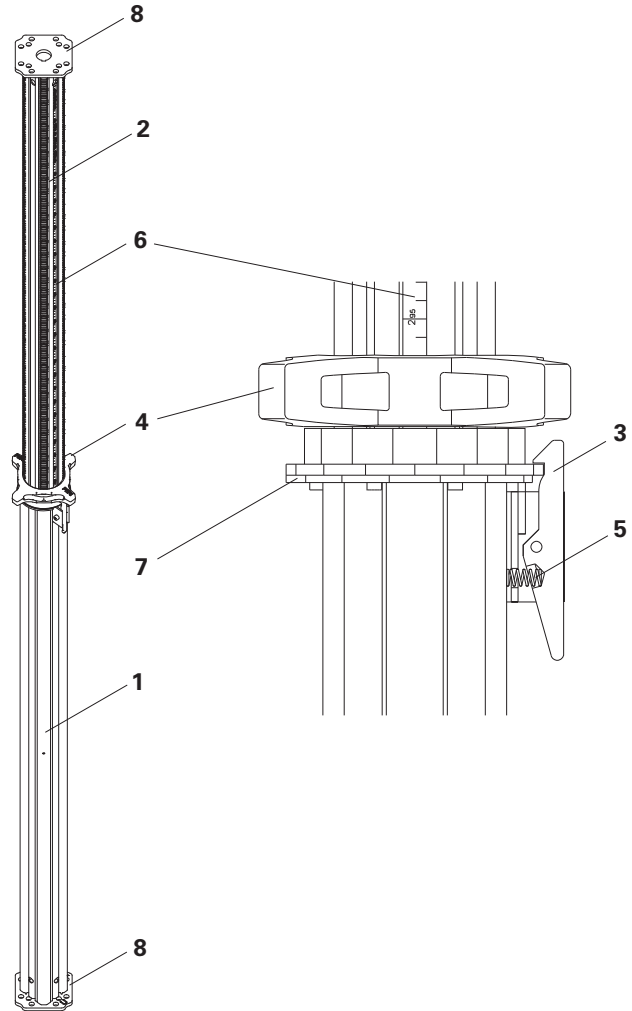

Base MP 50

- 11 Base MP 50
- 11a Head plate
- 11c Clamping claw
- 11b Centring pin

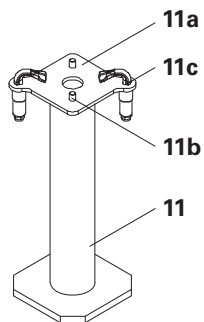

Key

Pictogram | Definition



Danger/Warning/Caution



Note



To be complied with



Load-bearing point



Visual inspection



Tip



Incorrect use



Safety helmet



Safety shoes



Safety gloves



Safety goggles



Personal protective equipment to prevent falling from a height (PPE)

Arrows



Arrow representing an action



Arrow representing a reaction of an action*



Arrow representing forces

* If not identical to the action arrow.

Safety instruction categories

The safety instructions alert site personnel to the risks involved and provide information on how to avoid these risks. Safety instructions can be found at the beginning of the section or before instructions for action and are highlighted as follows:



Danger

This sign indicates an extremely hazardous situation would result in death or serious, irreversible injury if the safety instructions are not followed.



Warning

This sign indicates a hazardous situation which could result in death or serious, irreversible injury if the safety instructions are not followed.



Caution

This sign indicates a hazardous situation which could result in minor or moderate injury if the safety instructions are not followed.



Note

This sign indicates situations in which failure to observe the information can result in material damage.

Format of the safety instructions



Signal word

Type and source of hazard!
Consequences of non-compliance.
⇒ Preventative measures.

Dimensions

Dimensions are usually given in cm. Other measurement units, e.g. m, are shown in the illustrations.

Conventions

- Instructions are numbered with:
1., 2., 3.
- The result of an instruction is shown by: →
- Position numbers are clearly provided for the individual components and are given in the drawing, e.g. **1**, in the text in brackets, for example **(1)**.
- Multiple position numbers, i.e. alternative components, are represented with a slash: e.g. **1/2**.

Notes on illustrations

The illustration on the front cover of these instructions is understood to be a system representation only. The assembly steps presented in these Instructions for Assembly and Use are shown in the form of examples with only one component size. They are valid for all component sizes contained in the standard configuration.

To facilitate understanding, detailed illustrations are sometimes incomplete. The safety equipment which might not have been shown in these detailed illustrations must nevertheless be available.

Target groups

Contractors

These assembly instructions are intended for contractors who either

- Assemble, modify and dismantle the scaffolding, or
- Use them, e.g. for pouring concrete, or
- Allow them to be used for other operations, e.g. carpentry or electrical work.

Safety and Health Protection Coordinator*

- Is appointed by the client,
- Must identify potential hazards during the planning phase,
- Determines measures that provide protection against risks,
- Creates a safety and health protection plan,
- Coordinates the protective measures for the contractor and site personnel so that they do not endanger each other,
- Monitors compliance with the protective measures.

Competent person

- Is appointed by the scaffolding contractor,
- Must be on site for all scaffolding work,
- Prepares and updates the plan for assembly, modification and dismantling,
- Prepares and updates the plan for use of the scaffold by the scaffold user,

- Supervises the assembly, modification and dismantling work (supervisor).

Competent persons qualified to carry out inspections

Due to the specialist knowledge gained from professional training, work experience and recent professional activity, the competent person qualified to carry out inspections has a reliable understanding of safety-related issues and can carry out inspections correctly. Depending on the complexity of the inspection to be undertaken, e.g. scope of testing, type of testing or the use of certain measuring devices, a range of specialist knowledge is necessary.

Qualified personnel

Scaffolds may only be assembled, modified or dismantled by personnel who are suitably qualified to do so. Qualified personnel must have completed a course of training** in the work to be performed, covering the following points at least:

- Explanation of the plan for the assembly, modification or dismantling of the scaffolding in an understandable form and language.
- Description of the measures for safely assembling, modifying or dismantling the scaffold.
- Naming of the preventive measures to be taken to avoid the risk of persons and objects falling.

- Designation of the safety precautions in the event of changing weather conditions that could adversely affect the safety of the scaffolding, as well as the personnel concerned.
- Details regarding permissible loads.
- Description of all other risks and dangers associated with assembly, modification or dismantling operations.



- **In other countries, ensure that the relevant national guidelines and regulations in the respective current version are complied with!**
- **If no country-specific regulations are available, it is recommended to proceed according to German guidelines and regulations.**

* Valid in Germany: Regulations for Occupational Health and Safety on Construction Sites 30 (RAB 30)

** Instructions are given by the contractor themselves or a competent person selected by them.

Additional technical documentation

- Brochure:
 - MULTIPROP Aluminium Slab Props
- Type tests for:
 - MULTIPROP Props
 - MULTIPROP System
 - MULTIPROP Props with Base MP 50
- Instructions for Use:
 - Pallets and stacking devices
- Instructions for Assembly and Use
 - MULTIFLEX
 - SKYDECK
 - TABLE MODULES/SLAB TABLES
 - SKYTABLE
 - VARIODECK
 - SKYMAX
- PERI Design Tables – Formwork and shoring

The structures shown in these Instructions for Assembly and Use are examples and feature only one prop type and component size. They are valid for all types and component sizes contained in the standard configuration.

Intended use

Product description

MULTIPROP Slab Props

- Are props made of aluminium,
- Correspond to the load requirements of DIN EN 16031,
- Are used as vertical supports for temporary constructions,
- Are used to transfer static loads.



MULTIPROP Slab Props are not designed for lifting or lowering loads.

Features

MULTIPROP Slab Props are used in shoring operations in a level, perpendicular position for the transfer of vertical loads. In particular, they also provide support for slab formwork systems.

The outer tubes of the MULTIPROP Slab Props are powder-coated.

The integrated measuring scale and free-running collar allow quick and accurate height adjustment.

The height is infinitely adjustable by means of the end-to-end thread without any pegging.

The MULTIPROP Slab Prop has a fail-safe feature which prevents the inner tube from unintentionally slipping out.

Main components

MULTIPROP

- MP 120, L = 0.80 – 1.20 m
- MP 250, L = 1.45 – 2.50 m
- MP 350, L = 1.95 – 3.50 m
- MP 480, L = 2.60 – 4.80 m
- MP 625, L = 4.30 – 6.25 m

System dimensions

Assembly heights as individual props according to the permissible extension lengths 0.80 m – 6.25 m or 1.30 m – 6.75 m together with Base MP 50.

Technical data

- Approval Z-8.312-824 (only for supports from production up to 31/12/2016)
- Type test S-N/160206
- For load-bearing capacities, see section "Design Tables: Permissible prop loads" on page 22.

Instructions for Use

Use in a way not intended, deviating from the standard configuration or the intended use according to the Instructions for Assembly and Use, represents an application with a potential safety risk, e.g. risk of falling.

Deviations from the standard configuration must be verified for the application by means of separate strength and stability calculations (Industrial Safety Regulation Appendix 1, No. 3.2.1) and explicitly reflected in the assembly instructions.

All components listed in the program overview may be used for assembly. Other components are not permitted. Exceptions are named, or must be planned and verified on a project-specific basis.

Only PERI original components may be used. The use of other products and spare parts is not allowed.

Changes to PERI components are not permitted.

The system described in these Instructions for Assembly and Use may contain patent-protected components.

Cleaning and maintenance instructions

Lubricate the rubbing plate on a regular basis in order to facilitate easier release of the adjusting nut when under load.

Before each use, check the adjusting nut for damage or cracks!

Clean the scaffold components after each use to maintain the value and operational readiness of the PERI products over the long term.

Some repair work may also be inevitable due to the tough working conditions.



The contractor must ensure that the personal protective equipment required for cleaning, maintenance and repair work, e.g.

- Safety helmet,
 - Safety shoes,
 - Safety gloves,
 - Safety goggles,
- is available and used as intended.

The following instructions should help to keep cleaning and maintenance costs as low as possible.

Cleaning tools must be adapted to the respective surfaces of the components so that they are not damaged.

Mechanical components, e.g. spindles, must be cleaned of dirt or concrete residue before and after use, and then greased with a suitable lubricant. The thread must not be greased.

Never clean powder-coated components, e.g. elements and accessories, with a steel brush or hard metal scraper; this ensures that the powder coating remains intact.

Provide suitable support for the components during cleaning so that no unintentional change in their position is possible.

Do not clean components suspended on crane lifting gear.

Components with wood parts are to be stored in well-ventilated and dry conditions.

Any repairs to PERI products are to be carried out by PERI qualified personnel only.

Disposal

Dispose of absorbed supports and components in accordance with the relevant national regulations.

Cross-system



Safety instructions apply to all service life phases of the system.

General

The contractor must guarantee that the Instructions for Assembly and Use supplied by PERI are available at all times and understood by the site personnel.

These Instructions for Assembly and Use can be used as the basis for creating a risk assessment. The risk assessment is compiled by the contractor. However, these Instructions for Assembly and Use are not a substitute for a risk assessment!

Observe and comply with the safety instructions and permissible loads.

For the application and inspection of PERI products, the current safety regulations and guidelines valid in the respective countries must be observed.

Materials and working areas are to be inspected before each use and assembly, for:

- Damage,
- Stability and
- Functional correctness.

Damaged components must be exchanged immediately on site and may no longer be used.

Safety components are to be removed only when they are no longer required.

When on slab formwork, scaffolds and working platforms:

- Do not jump,
- Do not run,
- Do not drop anything from or onto it.

Components provided by the contractor must comply with the characteristics stipulated in these Instructions for Assembly and Use and all applicable laws and standards. Unless otherwise indicated, the following applies in particular:

- Timber components: strength class C24 for solid wood according to EN 338.
- Scaffold tubes: galvanised steel tubing with minimum dimensions $\varnothing 48.3 \times 3.2$ mm according to EN 12811-1:2003 4.2.1.2.
- Scaffold tube couplings according to EN 74-1 and EN 74-2.

Deviations from the standard configuration are only permitted after a further risk assessment has been carried out by the contractor.

Appropriate measures for working and operational safety, as well as stability, are defined on the basis of this risk assessment.

Corresponding proof of stability can be provided by PERI on request, if the risk assessment and resulting measures to be implemented are made available.

Before and after exceptional occurrences that may have an adverse effect on the safety of the scaffolding system, the contractor must immediately

- Produce another risk assessment and make use of its results to take suitable steps to guarantee the stability of the scaffold system,
- Arrange for an extraordinary inspection to be carried out by a competent person qualified to do so. The aim of this inspection is to identify and rectify any damage in good time in order to guarantee safe use of the scaffold system.

Exceptional events could be:

- Accidents,
- Long periods of non-use,
- Natural events, e.g. heavy rainfall, icing, heavy snowfall, storms or earthquakes.

Assembly, modification and dismantling work

Assembly, modification or dismantling of shoring systems may only be carried out by qualified persons or under the supervision of a competent person. The qualified personnel must have received appropriate training for the work to be carried out with regard to specific risks and dangers.

On the basis of the risk assessment and Instructions for Assembly and Use, the contractor must create installation instructions, in order to ensure safe assembly, modification and dismantling of the climbing unit.

Before initial use, the safe functioning of the shoring systems must be checked by a person qualified to carry out the inspection. The results of the inspection must be documented in an inspection log.



The contractor must ensure that the personal protective equipment required for the assembly, modification or dismantling of the climbing formwork, e.g.

- Safety helmet,
- Safety shoes,
- Safety gloves,
- Safety goggles,

is available and used as intended.



If personal protective equipment against falling from a height (PPE) is required or specified in local regulations, the contractor must determine appropriate attachment points on the basis of the risk assessment.

The PPE against falling from a height that is to be used is determined by the contractor.

The contractor must

- Provide safe working areas for site personnel, which are to be reached through the provision of safe access ways. Cordon off and clearly mark danger zones.
- Guarantee stability during all stages of construction, in particular during assembly, modification and dismantling operations.
- Ensure and demonstrate that all loads that occur are safely transferred.

Use

Every contractor who uses or allows the scaffold systems to be used, is responsible for ensuring that the equipment is in good condition.

If the scaffold system is used successively or at the same time by several contractors, the health and safety coordinator must point out any possible mutual hazards and all work must be then coordinated.

System-specific

Strike components only when the concrete has sufficiently hardened and the person in charge has given the go-ahead for striking to take place.

Anchoring is to take place only if the anchorage has sufficient concrete strength.

The load-distributing support used, e.g. planking, must match the respective substrate. If multiple layers are required, planks are to be arranged crosswise.

After exceptional occurrences or long periods of downtime at the location where the formwork or shoring is used, the unit and its components must be checked for stability and functionality.

Pre-assembling the slab prop



- For the safety of the user, the following should be checked before every use to make sure
 - The slab prop is complete,
 - The slab prop and single components have no cracks, holes or broken off parts,
 - The inner tube and adjusting nut are freely movable and
 - The end plates are level.
- Shown here is the assembly of a free-standing MULTIPROP Slab Prop.
- When used in the system, the MULTIPROP System Instructions for Assembly and Use must be adhered to.
- The numbers on the integrated measuring scale show the complete length (**L**) of the MULTIPROP Slab Prop in metres [m], e.g. 125 = 1.25 m.
- The complete length of the MULTIPROP Slab Prop can be read at the upper edge of the adjusting nut (**4a**).
- Adjustment travel per revolution: 36 mm.
- The prop can be continuously readjusted by means of the adjusting nut if partially loaded up to 15 kN.

Preparation

MULTIPROP Slab Props are delivered with retracted inner tubes in a RP-2 pallet as standard.

Place the slab prop on an available work platform or the RP-2 pallet.

(Fig. A1.01a + A1.01b)

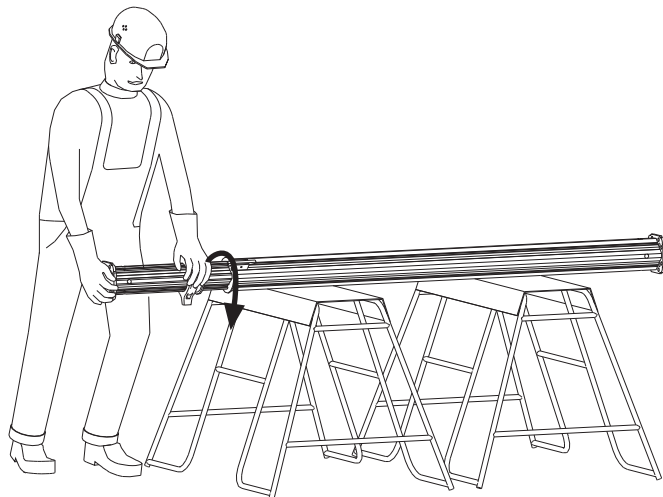

Fig. A1.01a

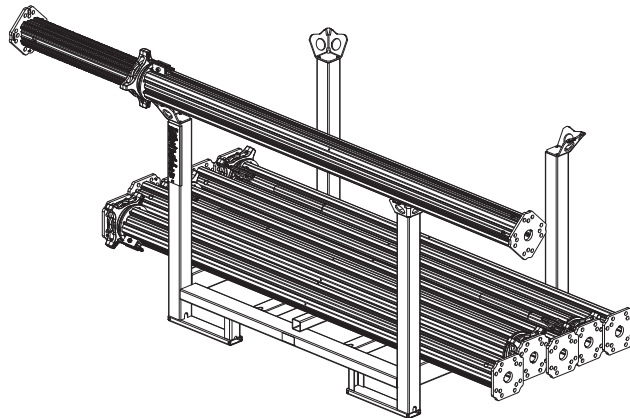

Fig. A1.01b

Turning direction of the adjusting nut

Position	Turn the adjusting nut	"L" gets:
Lower outer tube (Fig. A1.02b)	Anti-clockwise direction	Smaller
	Clockwise direction	Larger
Lower inner tube (Fig. A1.02c)	Anti-clockwise direction	Larger
	Clockwise direction	Smaller

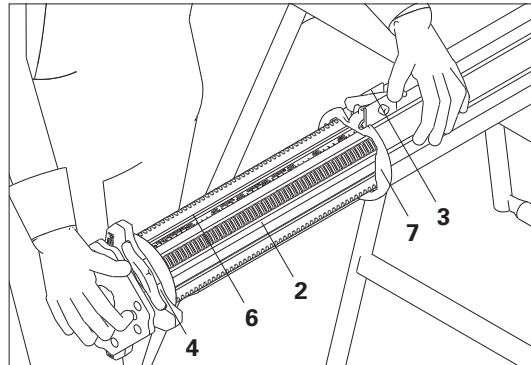
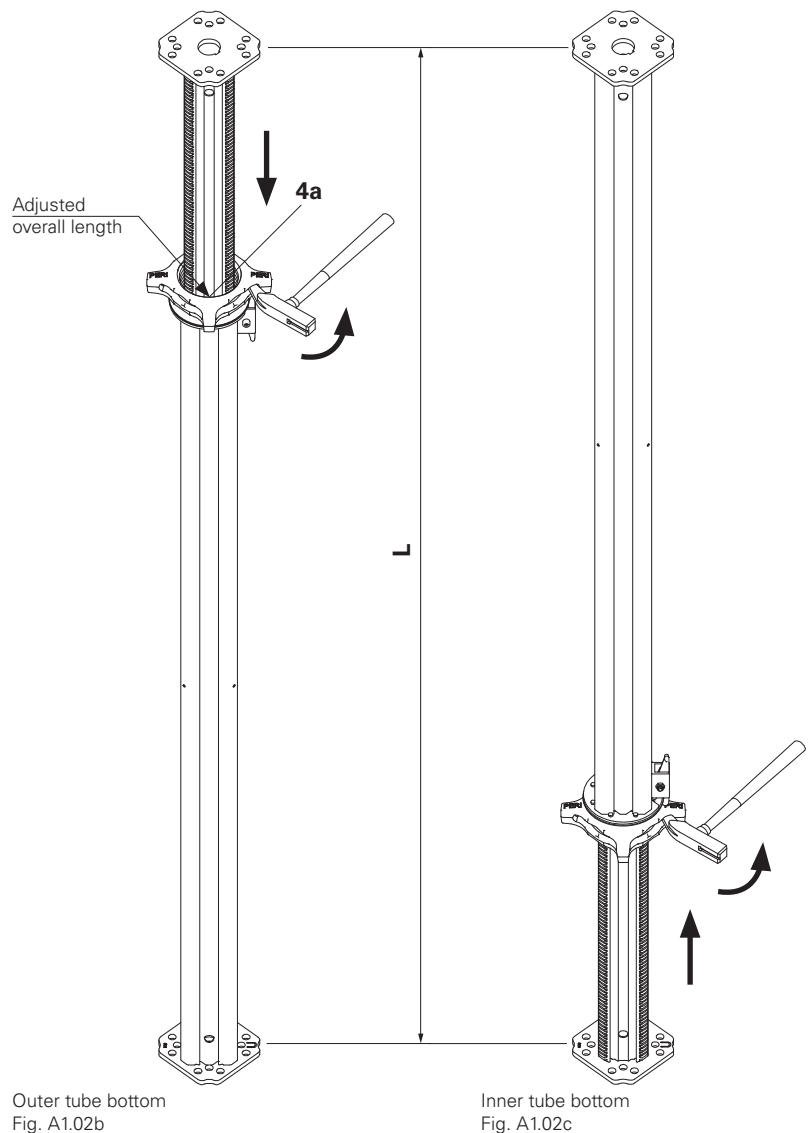

Fig. A1.02a

Rough adjustment of the extension length

1. Press safety hook (3).
→ Inner tube (2) together with the adjusting nut (4) is released.
(Fig. A1.02a)
2. Pull out the inner tube until the length indicated on the measuring scale (6) is slightly more than the required prop length.
3. Turn the adjusting nut until the required extension length is reached.
4. Push in the inner tube until the adjusting nut is lying against the rubbing plate (7).
→ The safety hook locks the inner tube in position.
5. Perform fine adjustment of the adjusting nut (4).



Outer tube bottom
Fig. A1.02b

Inner tube bottom
Fig. A1.02c



Is the safety hook engaged?



- The tip of the arrow on the quick jack nut indicates the direction for releasing.
- Quick adjustment of the smooth-running adjusting nut is carried out by "fast spindling".

Assembly with the universal tripod

For slab props with pipe \varnothing 57 mm to \varnothing 120 mm



- Universal tripods (9) are simply assembly aids for shuttering and striking up to heights of approx. 3 m.
- The slab prop and tripod are not suitable for a planned transfer of horizontal loads!
- Place the slab prop and tripod on a clean, flat and sufficiently load-bearing surface only!
- When used in the system, the respective Instructions for Assembly and Use are to be taken into account.
- Shown here is the assembly of a free-standing slab prop.

Universal tripod assembly

1. Insert the pre-assembled slab prop in the universal tripod (9).
2. Tighten brace stirrup (9a).
Ensure that the slab prop lies flat against the top and bottom connection plate (9b + 9c).

(Fig. A1.03)



Does the slab prop lie completely flat against the top and bottom connection plate?

- Has the brace stirrup been tightened?
- Is the slab prop in a perpendicular position?

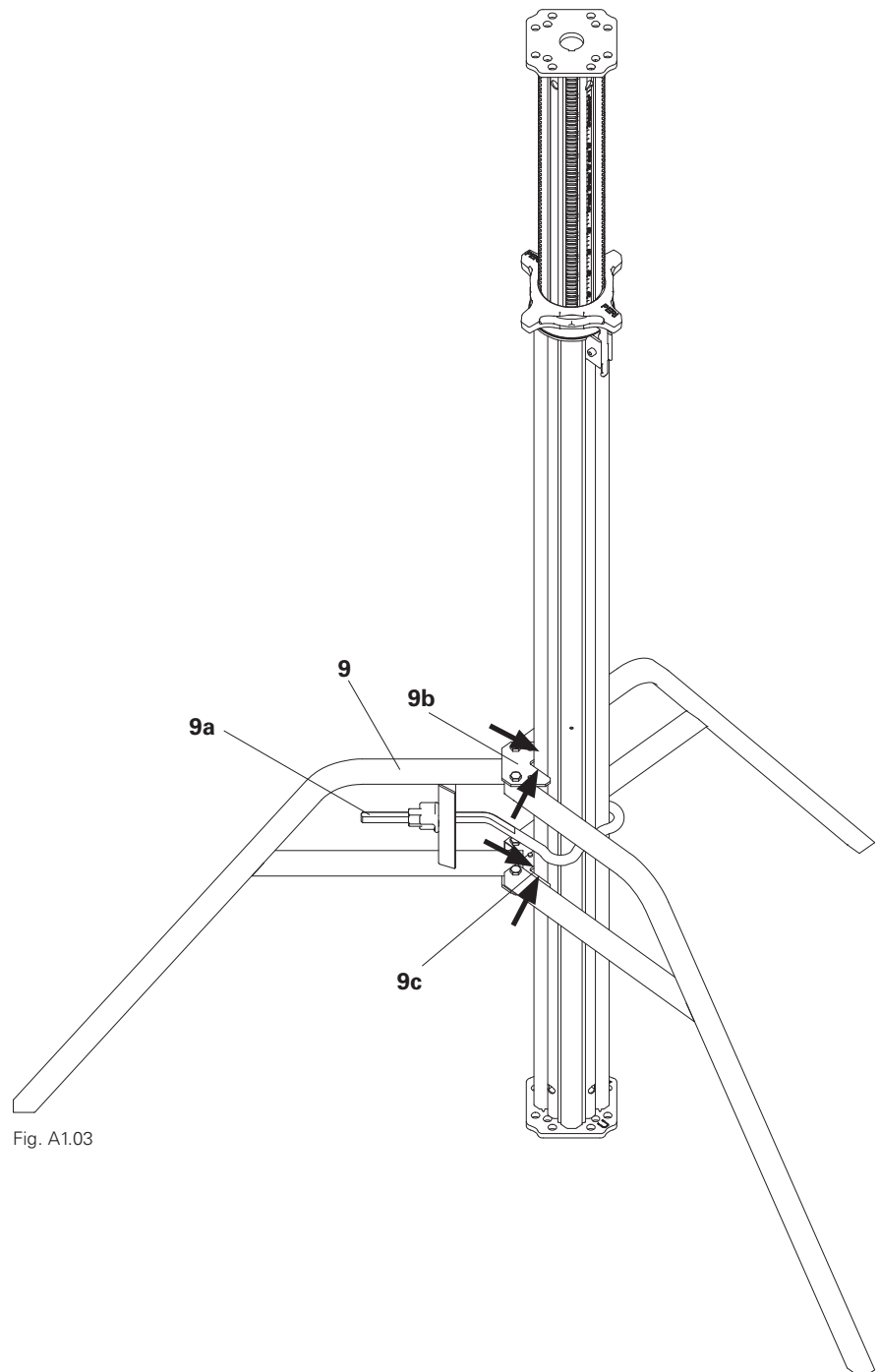

Fig. A1.03

Releasing the slab prop under load



- For loads ≤ 60 kN:
 - Use a hammer with a weight < 1 kg.
 - Use the wingnut spanner HD (100).
- For loads > 60 kN:
 - Only use the wingnut spanner HD (100)!

Disassembly

1. Release adjusting nut and set load free by:
 - Hammering lowering cam (Fig. A2.01a)
 - Using wingnut spanner HD (100) article no. 022027 (Fig. A2.01b)
2. Remove slab prop.
3. Dismantle slab prop.
 - Press down safety hook.
 - Inner tube with adjusting nut is released.
 - Pull out inner tube a short distance and turn adjusting nut back to the end plate.
 - Push in the inner tube until the adjusting nut is lying against the rubbing plate.
 - The safety hook locks the inner tube in position.
4. Place the slab prop in the pallet.



See Section A5 "Storage and Transportation".



The wingnut spanner HD

- Facilitates silent and effortless loosening of the adjusting nut – even when the props are placed under maximum load. Max. $F = 0.95$ kN.
- Can be extended using scaffold tube $\varnothing 48.3 \times 3.2$.

Lower outer tube

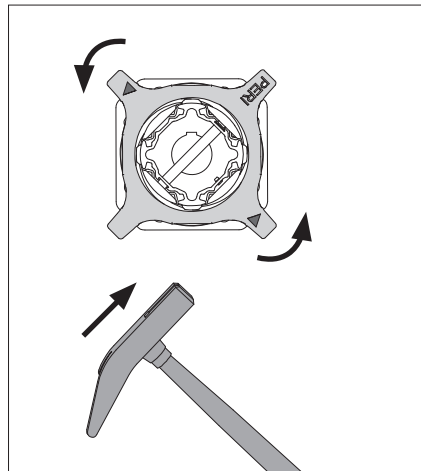
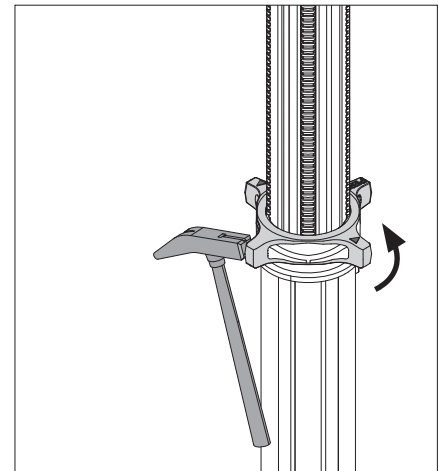

Fig. A2.01a



Lower outer tube

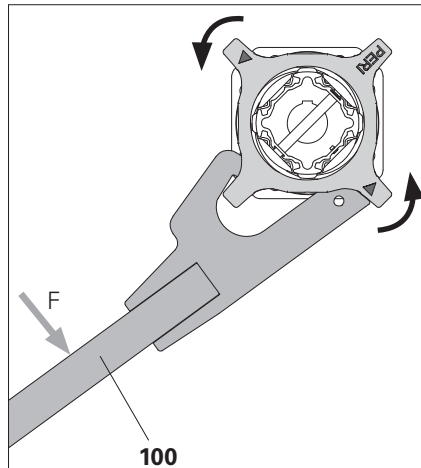
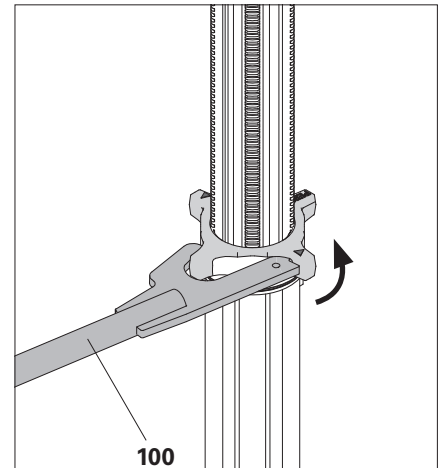

Fig. A2.01b



Brace clamp

Article no. 027790

Used as an alternative assembly aid with high slab props as of approx. 4 m using bracing boards 3 x 15 cm.



- Brace clamps are not suitable for a level transfer of horizontal loads!
- Brace clamps (**10**) are simply assembly aids for shuttering and striking procedures.
- As an option, universal tripods can be used as additional assembly aids.

Assembly

1. Pull the narrow side of the wedge (**10a**) out of the clamp.
2. Place brace clamp (**10**) around the tube of the slab prop.
3. Insert board in the open side of the clamp.
4. Put wedge back into recess of the clamp and hammer in securely.
→ The wedge secures the board.
5. Mount additional bracing boards by means of brace clamps.

(Fig. A3.01)



- Are the slab props in a perpendicular position?
- Have all wedges been securely fixed?
- Have all wedges been used to secure the boards?

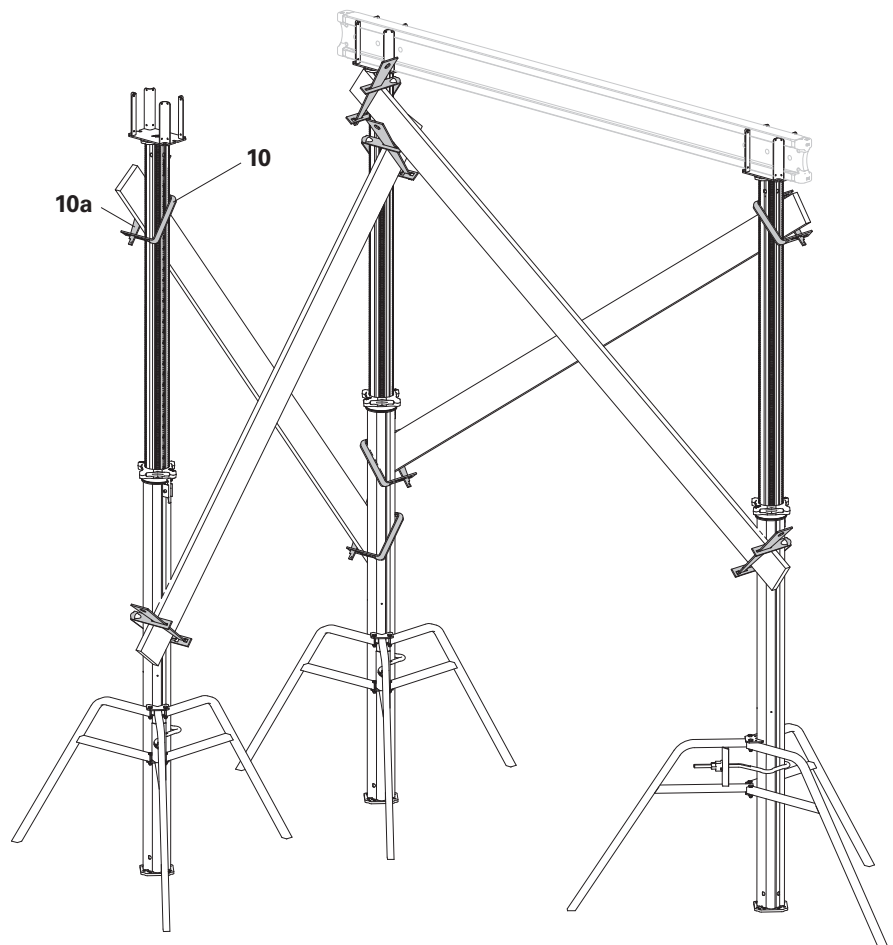

Fig. A3.01

Base MP 50

Article no. 027310

Used to extend the slab prop by 50 cm.
Automatic centring of the slab prop by means of centring pins.

Two clamping claws connect the Base MP 50 to the slab prop.

The MULTIPROP Prop can be mounted on the Base MP 50 with the inner or outer tube.



Take into account separate Design Tables with permissible prop load!

Assembly

1. Place the slab prop on the head plate (11a) of the Base MP 50 so that the two centring pins (11b) lock into the holes of the end plate.
2. Position the clamping claws (11c) with the hammer on the end plate of the slab prop.
Base MP 50 (11) is now connected to the prop.

(Fig. A3.02)



Are the two clamping claws set down fully on the end plate?



The same type of prop can be used at different heights when using Base MP 50.

Disassembly

Release clamping claws by means of a hammer.

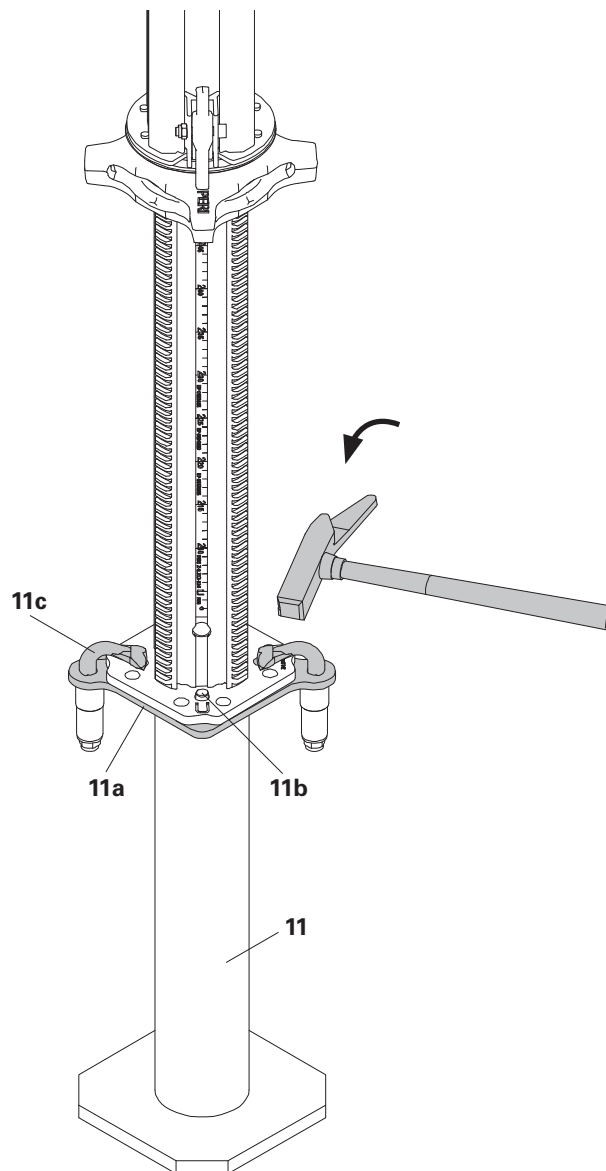

Fig. A3.02

A4 Foreseeable misapplications



Do not use damaged parts

⇒ Do not use props with cracks in the nut!
(Fig. A4.01a)

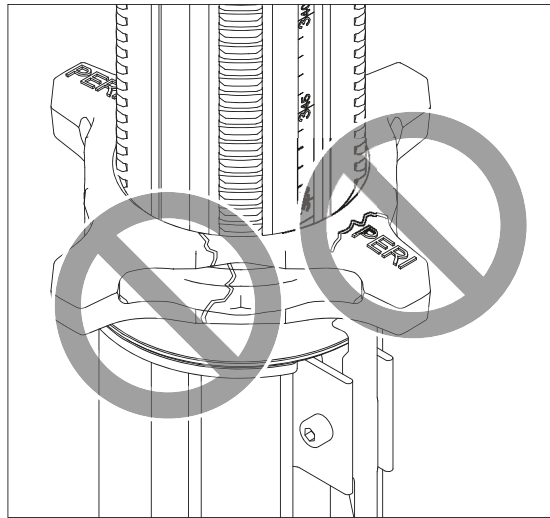

Fig. A4.01a

⇒ Do not use slab props with bent end plates or cracked seams on the end plates!
(Fig. A4.01b)

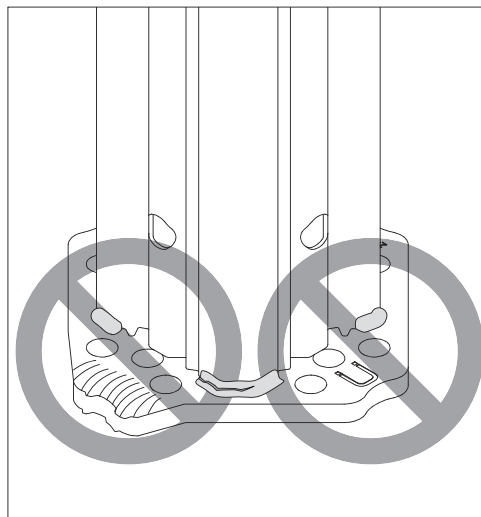

Fig. A4.01b

⇒ Do not use slab props with bent rubbing plates!
(Fig. A4.01c)

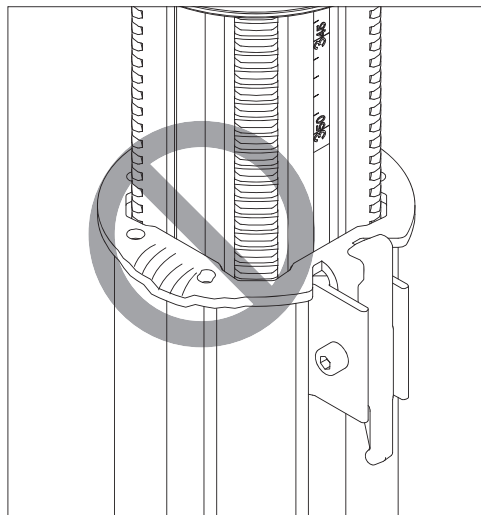

Fig. A4.01c



Ensure slab props are in a perpendicular position

⇒ Slab props must always be in a vertical position.

(Fig. A4.02)

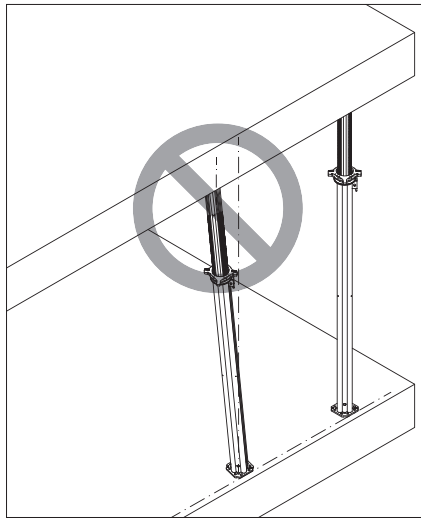

Fig. A4.02



No full-faced support surfaces

⇒ End plates of the slab props must always lie completely flat.

If necessary, fill the gap and secure the wedge.

(Fig. A4.03a + A4.03b)

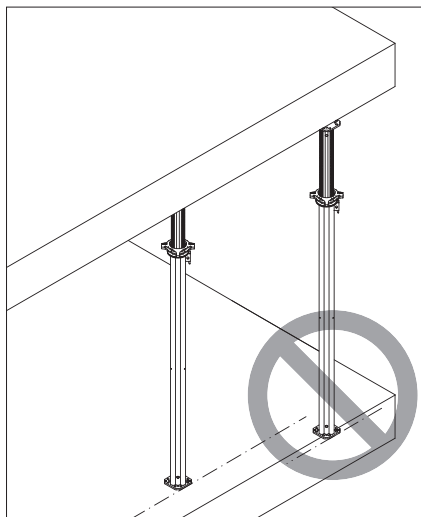

Fig. A4.03a

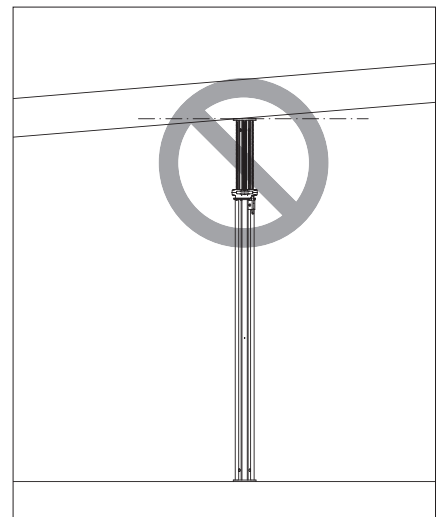

Fig. A4.03b



Non-loadable erection surface

⇒ Slab props must always be positioned on load-bearing and flat surfaces.

(Fig. A4.04a + A4.04b)

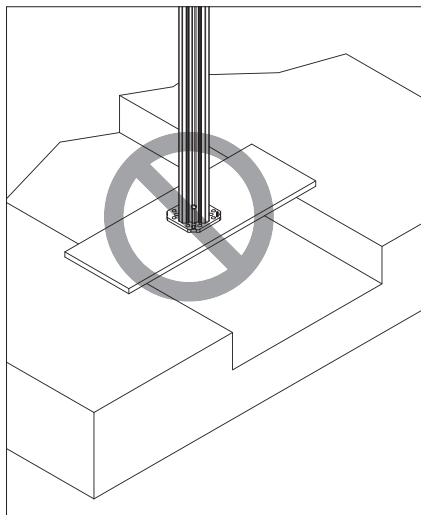

Fig. A4.04a

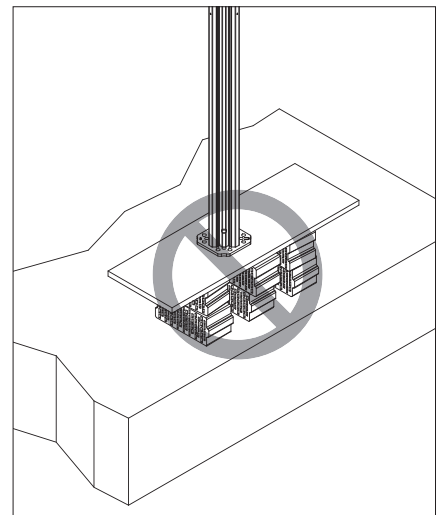

Fig. A4.04b



Do not connect several slab props

⇒ If the clearance height is too large, a longer slab prop or shoring tower must be used, e.g. MULTIPROP System with MRK Frames.

(Fig. A4.05)

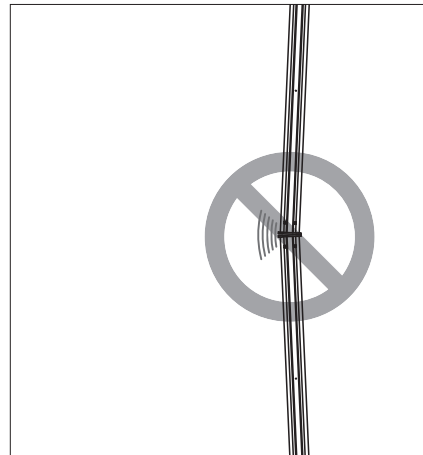

Fig. A4.05



Do not use with the Tilting Forkhead MKK or Tilting Base MKF

⇒ If the clearance height is too large, a longer slab prop or shoring tower must be used, e.g. MULTIPROP System with MRK Frames.

(Fig. A4.06)

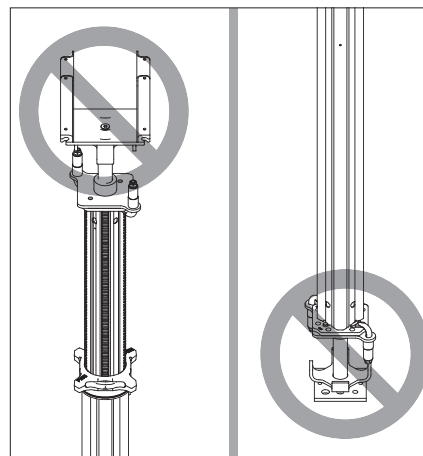

Fig. A4.06



Do not use to support formwork elements

⇒ Use designated support equipment, e.g. push-pull props or brace frames.

(Fig. A4.07)

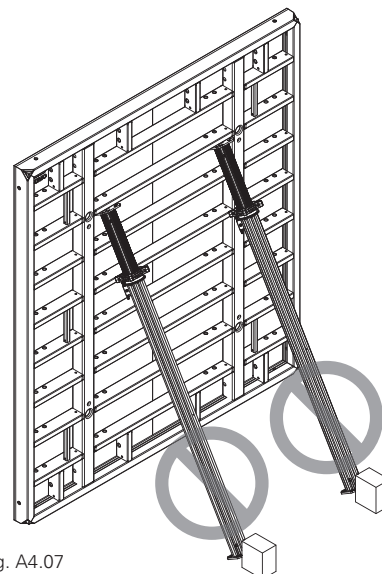

Fig. A4.07



Do not use as a trench strut

⇒ Use designated trench strut.
(Fig. A4.08)

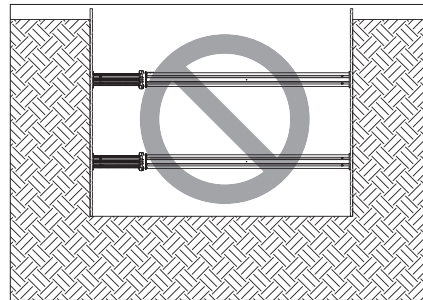

Fig. A4.08



Do not use as guardrail

⇒ Use designated guardrail, e.g.
PROKIT EP 110 or EP 200.
(Fig. A4.09)

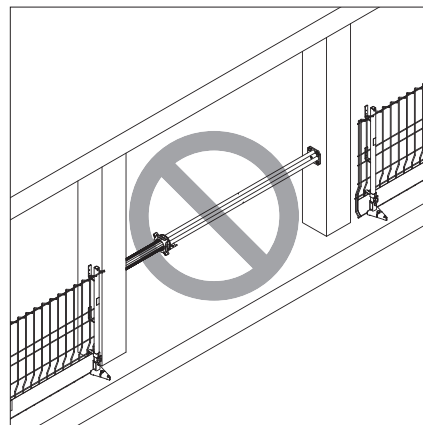

Fig. A4.09



Do not use as a guardrail holder

⇒ Use designated guardrail, e.g.
PROKIT EP 110 or EP 200.
(Fig. A4.10)

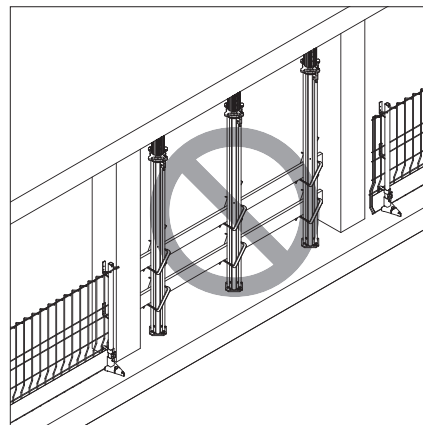

Fig. A4.10



- Store and transport components in such a way that no unintentional change in their position is possible.
- Detach lifting accessories and lifting gear from the lowered components only if they are in a stable position and no unintentional change is possible.
- Do not drop the components.
- Use PERI lifting accessories and lifting gear and only those load-bearing points provided on the component.
- During the relocation procedure
 - Ensure that components are picked up and set down so that unintentional falling over, falling apart, sliding, falling down or rolling is avoided.
 - No persons are allowed to remain under the suspended load.
- The access areas on the construction site must be free of obstacles and tripping hazards and must also be slip-resistant.
- For transportation, the substrate must have sufficient load-bearing capacity.
- Use original PERI storage and transport systems, e.g. crate pallets, pallets or stacking devices.
- The Instructions for Use for PERI pallets and stacking devices must be observed!
- Follow PERI packaging guidelines!
- Transportation units must be correctly stacked and secured!

PERI pallets (**14**) are suitable for lifting by crane and forklift. When using a crane, four-sling lifting gear is used to move the pallets. During forklift operations, the PERI pallets can be moved either by a forklift truck or by using the lifting trolley. All pallets can be picked up from the long side as well as from the front side. Max. number of pallets in accordance with packaging guidelines.



The safety hook (**3**) prevents the inner tube (**2**) from slipping out and must be engaged. (Fig.)

Storage



- Only store and transport slab props of the same size.
 - Only transport slab props when fully retracted.
 - Stack the slab props alternately (outer tube and inner tube alternately).
- (Fig. A5.01 + A05.02)

Delivery unit: 25 pieces

Transportation



- Only transport slab props in Pallets RP-2.
- Ensure loads are correctly secured during transport!
- Use tension belts or steel bands.

The number of pallets to be transported depends on the national transport regulations.

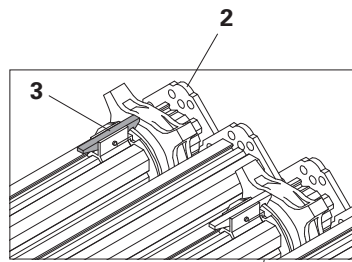

Fig. A5.01a

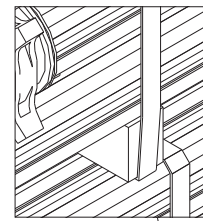

Fig. A5.02a

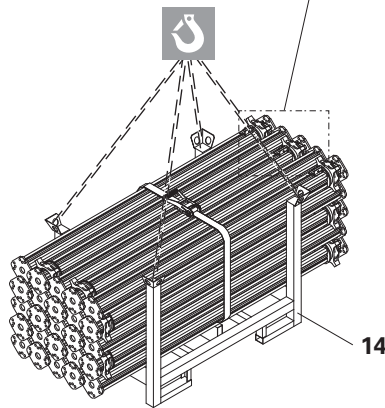

Fig. A5.01

Example: MULTIPROP Slab Props positioned horizontally in an RP-2 Pallet and secured by means of a tension belt.

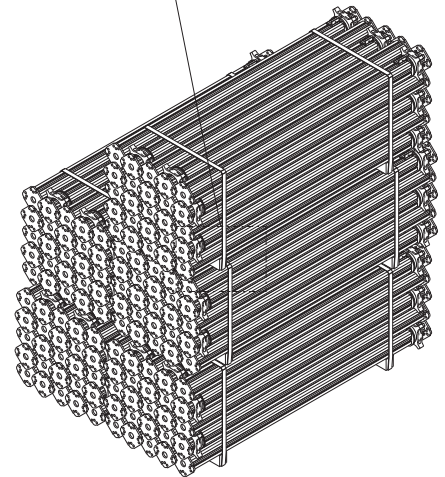

Fig. A5.02

Example: MULTIPROP Slab Props stacked using battens and secured by means of a steel band.

MULTIPROP 120, 250, 350

Permissible prop load [kN] according to type test						
Extension length [cm]	MP 120 L = 0.80 – 1.20 m		MP 250 L = 1.45 – 2.50 m		MP 350 L = 1.95 – 3.50 m	
	Lower outer tube	Lower inner tube	Lower outer tube	Lower inner tube	Lower outer tube	Lower inner tube
80	89.3	102.0				
90	89.0	102.0				
100	88.7	102.0				
110	88.7	98.0				
120	88.7	94.0				
130						
140						
150			99.3	94.0		
160			99.3	94.0		
170			99.3	94.0		
180			97.2	94.0		
190			92.9	94.0		
200			88.7	94.0	96.0	94.7
210			86.5	94.0	93.1	94.7
220			84.4	94.0	90.1	94.7
230			82.5	92.4	87.5	94.1
240			80.9	89.2	85.1	93.1
250			79.3	86.0	82.7	92.0
260					79.3	88.7
270					76.0	85.3
280					73.3	82.7
290					70.7	80.0
300					68.7	77.0
310					66.7	74.0
320					63.1	71.0
330					59.6	68.0
340					54.7	61.5
350					49.8	54.9

Load-bearing capacity according to DIN EN 16031.



For releasing loads > 60 kN, use the wingnut spanner HD, article no. 022027.

MULTIPROP 480, 625

Permissible prop load [kN] according to type test				
Extension length [cm]	MP 480 L = 2.60 – 4.80 m		MP 625 L = 4.30 – 6.25 m	
	Lower outer tube	Lower inner tube	Lower outer tube	Lower inner tube
	260	88.7	94.0	
270	87.8	92.3		
280	87.0	90.7		
290	86.2	89.0		
300	85.3	87.3		
310	80.2	84.9		
320	75.1	82.5		
330	70.0	80.0		
340	66.6	77.3		
350	63.2	74.7		
360	59.7	72.0		
370	56.2	67.4		
380	52.8	62.7		
390	49.3	58.1		
400	46.3	54.1		
410	43.3	50.0		
420	40.3	45.9		
430	38.0	43.3	57.9	45.7
440	35.7	40.8	56.3	45.7
450	33.5	38.2	54.7	45.7
460	31.2	35.6	52.5	45.1
470	28.9	33.1	50.2	44.5
480	26.7	30.5	47.8	43.6
490			45.1	42.5
500			42.4	41.3
510			39.8	39.9
520			37.2	38.5
530			34.9	37.0
540			32.9	35.6
550			30.9	34.1
560			29.3	32.6
570			27.7	31.1
580			26.3	29.5
590			25.0	27.9
600			23.7	26.2
610			22.6	24.8
620			21.5	23.4
625			21.0	22.7



For releasing loads > 60 kN, use the wingnut spanner HD, article no. 022027.

Load-bearing capacity according to DIN EN 16031.

MULTIPROP 120, 250, 350 with Base MP 50

Permissible prop load [kN] according to type test

Overall height [cm] (prop extension +50 cm)	MP 120 + MP 50 L = 1.30 – 1.70 m		MP 250 + MP 50 L = 1.95 – 3.00 m		MP 350 + MP 50 L = 2.45 – 4.00 m	
	Lower outer tube	Lower inner tube	Lower outer tube	Lower inner tube	Lower outer tube	Lower inner tube
130	88.0	84.7				
140	88.0	83.3				
150	88.0	82.0				
160	86.3	80.3				
170	84.7	78.7				
180						
190						
200			89.3	94.0		
210			89.3	94.0		
220			89.3	94.0		
225			89.3	94.0		
230			88.1	93.7		
240			85.7	93.2		
250			83.3	92.7	88.7	85.3
260			79.9	88.9	88.7	85.3
270			76.4	85.2	88.7	85.3
280			72.9	80.5	86.4	85.3
290			69.3	74.9	81.9	85.3
300			65.7	69.3	77.3	85.3
310					73.3	82.3
320					69.3	79.3
330					65.6	72.1
340					61.8	64.9
350					57.4	60.7
310					53.1	56.4
370					49.4	52.2
380					45.7	48.0
390					42.4	44.0
400					39.1	40.0

Load-bearing capacity according to
DIN EN 16031.



For releasing loads > 60 kN, use the
wingnut spanner HD, article no. 022027.

MULTIPROP 480, 625 with Base MP 50

Permissible prop load [kN] according to type test				
Overall height [cm] (prop extension +50 cm)	MP 480 + MP 50 L = 3.10 – 5.30 m		MP 625 + MP 50 L = 4.80 – 6.75 m	
	Lower outer tube	Lower inner tube	Lower outer tube	Lower inner tube
310	88.7	81.3		
320	86.3	81.0		
330	84.0	80.7		
340	81.7	80.3		
350	79.3	80.0		
360	73.3	75.8		
370	67.2	71.5		
380	61.2	67.3		
390	56.9	62.9		
400	52.6	58.4		
410	48.3	53.9		
420	45.5	50.1		
430	42.6	46.3		
440	39.8	42.5		
450	37.6	40.0		
460	35.5	37.5		
470	33.3	35.0		
480	31.7	33.2	48.7	44.5
490	30.0	31.4	47.5	44.4
500	28.4	29.6	46.3	44.3
510	26.8	27.8	44.6	43.1
520	25.1	26.1	42.9	41.8
530	23.5	24.3	41.1	40.4
540			39.2	38.8
550			37.3	37.1
560			35.3	35.6
570			33.3	34.0
580			31.5	32.5
590			29.8	31.0
600			28.1	29.5
610			26.7	28.1
620			25.3	26.7
630			24.1	25.4
640			22.9	24.2
650			21.8	22.9
660			20.8	21.8
670			19.8	20.6
675			19.3	20.0



For releasing loads > 60 kN,
use the wingnut spanner HD,
article no. 022027.

Load-bearing capacity according to DIN EN 16031.

MULTIPROP Slab Props

Article no. Weight kg

027288	10,200
027289	15,400
027290	19,500
027291	24,700
027305	34,500

MULTIPROP MP
MULTIPROP MP 120
MULTIPROP MP 250
MULTIPROP MP 350
MULTIPROP MP 480
MULTIPROP MP 625

Slab prop made of aluminium. Used as individual prop as well as in combination with MULTIPROP MRK Frames to form towers.

min. L	max. L
800	1200
1450	2500
1950	3500
2600	4800
4300	6250

Technical data

Permissible load: see PERI Design Tables.

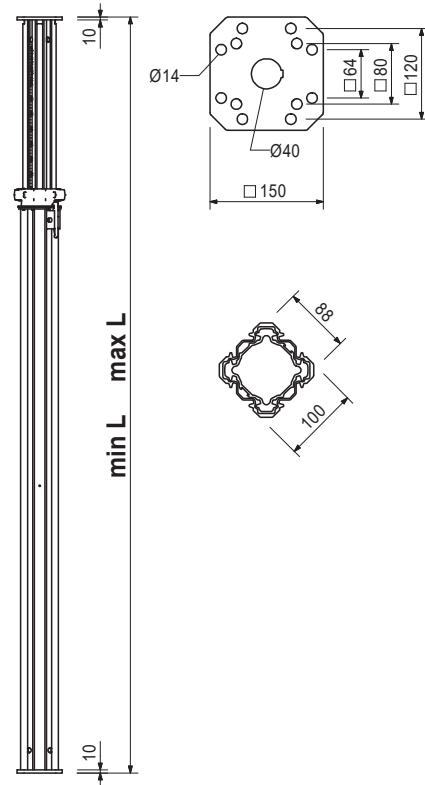

028000 9,190

Universal tripod 57 - 120

Erection aid for slab props with Ø 57 – 120 mm and 120 x 120 mm. Can also be used in combination with MULTIPROP MP Slab Props and all slab props with Base MP 50.

Note

Only use as erection aid!

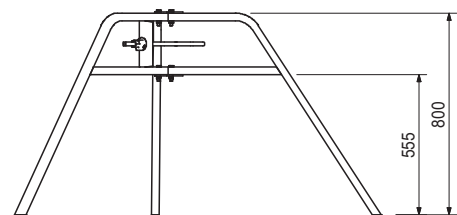
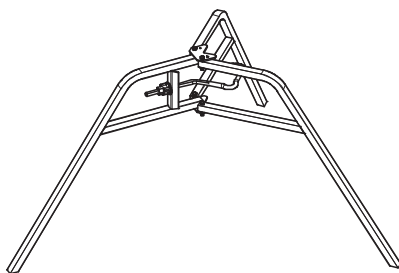

Article no. Weight kg

027790 2,460

Brace Clamp HL, galv., 76 – 120 mm

For assembly of 3 x 15 cm stiffening boards at slab props \varnothing 76 – 89 mm and 100 x 100 mm to 120 x 120 mm.

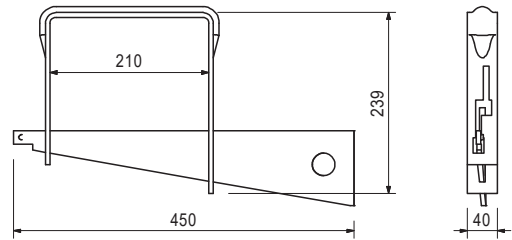
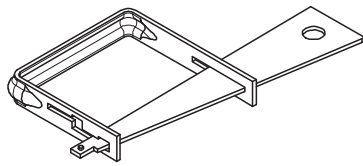

022027

3,600

Wingnut spanner HD

For easy release of Head Spindle HDK 45, Head Spindle TR 110-80/55 and the MULTIPROP Slab Prop.

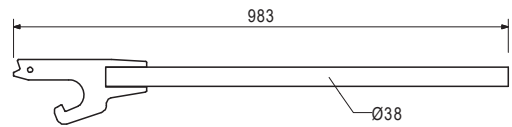
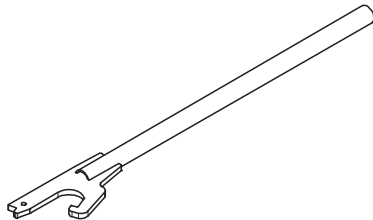

027310

8,900

Base MP 50

For use with slab props with an end plate thickness of 6 – 10 mm. With clamped quick-release fastener.

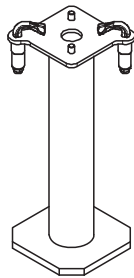

Note

Permissible load: see PERI Design Tables.

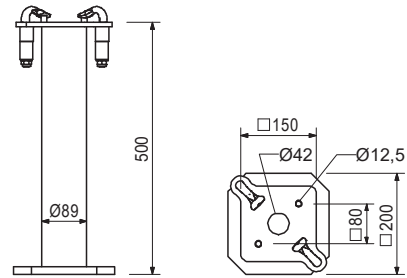

MULTIPROP Slap Props



Article no. Weight kg

103434	38,500
103429	45,300

Pallets RP-2, galv.

Pallet RP-2 80 x 120, galv.

Pallet RP-2 80 x 150, galv.

For stacking and transportation of formwork and scaffolding components.

Note

Follow Instructions for Use!

Technical data

Permissible load-bearing capacity 1.5 t.

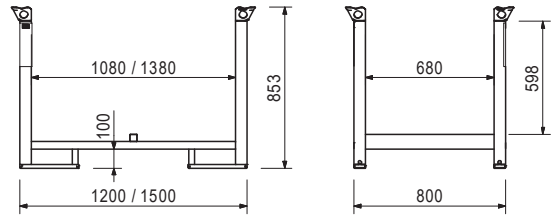
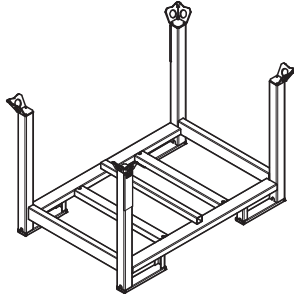

The optimal system
for all projects and
every requirement



Wall formwork



Column formwork



Slab formwork



Climbing systems

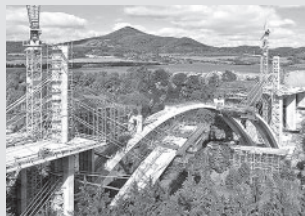

Bridge formwork



Tunnel formwork



Shoring



Working scaffold construction



Working scaffold façade



Working scaffold industry



Means of access



Safety scaffolds



Safety systems

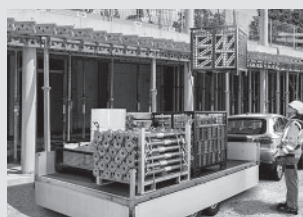

System-independent accessories



Services



PERI SE
Formwork Scaffolding Engineering
Rudolf-Diesel-Strasse 19
89264 Weissenhom, Germany
Germany
Telephone +49 (0)7309.950-0
Fax +49 (0)7309.951-0
info@peri.de
www.peri.com



PERI Australia Pty Ltd
Formwork Scaffolding Engineering
116 Glendenning Rd
Glendenning NSW 2761
Australia
Telephone +61 (2) 8805 2300
Fax +61 (2) 9675 7277
info@peri.com.au
www.peri.com.au