

# PERI UP Flex

## Staircase 100 and 125 with Deck UDG

Instructions for Assembly and Use – Standard Configuration – Version 2.0 AU 01.2022



<b>Overview</b>			
Components	3	A4 Anchoring	40
Key	4	Triangulated tie	40
<b>Introduction</b>		Single wall ties with bracing	41
Target groups	5	A5 Dismantling	42
Product description	6	A6 Stair Tower 125	43
Intended use	6	Step width 125 cm	43
Cleaning and maintenance instructions	7	<b>Labels</b>	
Information regarding relocation		B1 Live loads	44
by crane	7	Loads on Steps UAR	44
Additional technical documentation	8	Loads on flights of stairs and landing platforms	44
Instructions for Use	8	Loads on stair tower	44
<b>Safety instructions</b>		B2 Support forces	46
Cross-system	9	Step width 100 cm	46
System-specific	11	Step width 125 cm	47
Anchoring	11	B3 Ties, tie forces	48
Checking the anchoring	11	Tie positions – installation heights	48
Storage and transportation	11	Anchor forces	49
Identification marking	12	<b>Program overview</b>	
Laws and regulations	12	PERI UP Flex Treppe 100, 125	50
Inspection, handover and use	13		
Safety during assembly	14		
Verified attachment points	14		
<b>Safety during assembly</b>			
Attachment points in the system	15		
<b>Assembly</b>			
A1 Base level	16		
General	16		
Load-distributing supports	16		
Base level	16		
A2 First staircase	18		
Standards and ledgers, guardrail in advance	18		
Preparing for hoisting operations involving cranes	19		
Decks and braces	20		
Stair stringers	21		
Steps	22		
Bracing	25		
Guardrail	26		
Landing variants	27		
A3 Additional staircases	28		
Standards and ledgers, guardrail in advance	28		
Decks and braces	29		
Stair stringers	33		
Ledger braces	34		
Steps	35		
Guardrail	36		
Additional flights of stairs	37		
Last flight of stairs	37		
Access into the building	38		
Footbridge	39		

## Components

Pos. no.	Designation	Article no.
1	Base Spindle UJB	116762
2	Base Standard UVB 25	133499
3	Horizontal Ledger UH-2 250	132025
4	Horizontal Ledger UH-2 200	132016
5	Horizontal Ledger UH-2 100	132004
6	Horizontal Ledger UH-2 125 <sup>2)</sup>	132007
7	Standard UVR-2 300	132239
8	Standard UVR-2 200	132234
11	Stair Stringer UA 250/200	109219
12	Step UAR 100	109198
13	End Step UAE 100	109208
14	Stair Stringer UA 125/100 <sup>1)</sup>	114731
15	Step UAR 125 <sup>2)</sup>	114179
16	End Step UAE 125 <sup>2)</sup>	114180
31	Steel Deck UDG-2 25 x 100	132492
32	Steel Deck UDG-2 25 x 200	132508
33	Steel Deck UDG-2 25 x 125 <sup>2)</sup>	132502
34	Steel Deck UDG-2 25 x 250	132511
41	Node Brace UBK-2 250/200	133454
42	Ledger Brace UBL-2 200/200	132795
43	Horizontal Brace UBH Flex 250/100	114819
44	Horizontal Brace UBH Flex 100/100	114818
45	Ledger Brace UBL-2 250/200	132816
46	Horizontal Brace UBH Flex 250/125 <sup>2)</sup>	114996
47	Horizontal Brace UBH Flex 125/125 <sup>2)</sup>	114904
51	Ledger-to-Ledger Coupler UHA-2	136582
52	Locking pin Ø 48/57	111053
53	Wall Tie UWT 45	100088
54	Wall Tie UWT 140	100093
55	Standard Coupler RA 48/48	017020
56	Swivel Coupling AF 48/48	017010
57	Scaffold tube 48.3 x 3.2	026415
58	Spindle Locking UJS	100863
	1) for half the storey height	
	2) for Stair Tower 125 only	

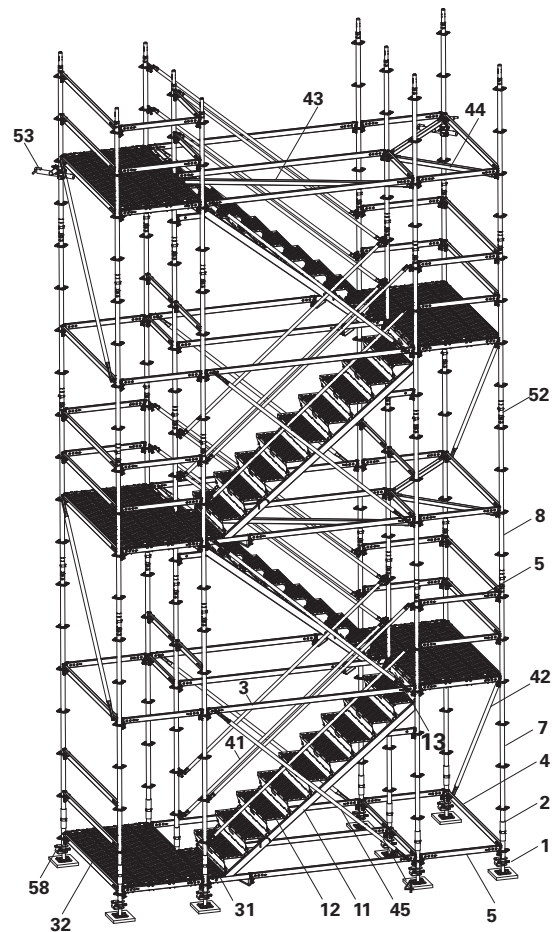

### Terminology

Components are not always named in full so that they are easier to read. All components deemed valid according to the program overview may be used. Exceptions are specified.

Example:

- Horizontal ledger
- equally valid:
- Horizontal Ledger UH Plus
  - Horizontal Ledger UH-2

### Program overview

Article numbers beginning with the numbers 3 and 4 are only available as rental or used items.

## Key

### Pictogram | Definition



Danger/Warning/Caution



Note



To be complied with



Visual inspection



Tip



Incorrect use



Correct use



Load-bearing point



Safety helmet



Safety shoes



Safety gloves



Safety goggles



Personal protective equipment to prevent falling from a height (PPE)

### Arrows in the illustrations



Arrow representing an action



Arrow representing a reaction of an action\*



Arrow representing forces

\* If not identical to the action arrow.

### Safety instruction categories

The safety instructions alert site personnel to the risks involved and provide information on how to avoid these risks. Safety instructions are featured at the beginning of the section or ahead of the instructions, and are highlighted as follows:



#### Danger

This sign indicates an extremely hazardous situation, in which case, not following the safety instructions will result in death or serious, irreversible injury.



#### Warning

This sign indicates a hazardous situation which, if not avoided, could result in death or serious, irreversible injury.



#### Caution

This sign indicates a hazardous situation, in which case, not following the safety instructions could result in minor or moderate injury.



#### Note

This sign indicates situations in which failure to observe the information can result in material damage.

### Format of the safety instructions



#### Signal word

Type and source of hazard!  
Consequences of non-compliance.  
⇒ Preventative measures.

### Conventions

- Instructions are numbered with:  
1. ...., 2. ...., 3. ....
- The result of an instruction is shown by: →
- Position numbers are clearly provided for the individual components and are given in the drawing, e.g. **1**, in the text in brackets, for example **(1)**. Multiple position numbers, i.e. alternative components, are represented with a slash: e.g. **1/2**.

### Units shown in the illustrations

Dimensions featured in the illustrations are in cm, but without units. Deviating units specified in addition, e.g. in m.

Exception:

In the Program overview section, measurements are always given in mm.

Load details featured in the illustrations are in kg, but without units.

Deviating units specified in addition, e.g. in t.

### Notes on illustrations

The illustration on the front cover of these instructions is understood to be a system representation only. The assembly steps presented in these Instructions for Assembly and Use are shown in the form of examples with only one component size.

They are valid for all component sizes contained in the standard configuration.

To facilitate understanding, detailed illustrations are sometimes incomplete. The safety installations which have possibly not been shown in these detailed illustrations must nevertheless be available.

## Target groups

### Contractors

These assembly instructions are intended for contractors who either

- assemble, modify and dismantle the scaffolding, or
- use them, e.g. for concreting, or
- allow them to be used for other operations, e.g. carpentry or electrical work.

### Safety and Health Protection Coordinator\*

- is appointed by the client,
- must identify potential hazards during the planning phase,
- determines measures that provide protection against risks,
- creates a safety and health protection plan,
- coordinates the protective measures for the contractor and site personnel so that they do not endanger each other,
- monitors compliance with the protective measures.

### Competent person

- is appointed by the scaffolding contractor,
- must be on site for all scaffolding work,
- prepares and updates the plan for assembly, modification and dismantling,
- prepares and updates the plan for use of the scaffold by the scaffold user,
- supervises the assembly, modification and dismantling work (supervisor).

### Competent persons qualified to carry out inspections

Due to the specialist knowledge gained from professional training, work experience and recent professional activity, the competent person qualified to carry out inspections has a reliable understanding of safety-related issues and can carry out inspections correctly. Depending on the complexity of the inspection to be undertaken, e.g. scope of testing, type of testing or the use of certain measuring devices, a range of specialist knowledge is necessary.

### Qualified personnel

Scaffolds may only be assembled, modified or dismantled by personnel who are suitably qualified to do so. Qualified personnel must have completed a course of training\*\* in the work to be performed, covering the following points at least:

- Explanation of the plan for the assembly, modification or dismantling of the scaffolding in an understandable form and language.
- Description of the measures for safely assembling, modifying or dismantling the scaffold.
- Naming of the preventive measures to be taken to avoid the risk of persons and objects falling.

- Designation of the safety precautions in the event of changing weather conditions that could adversely affect the safety of the scaffolding, as well as the personnel concerned.
- Details regarding permissible loads.
- Description of all other risks and dangers associated with assembly, modification or dismantling operations.



- **In other countries, ensure that the relevant national guidelines and regulations in the respective current version are complied with!**
- **If no country-specific regulations are available, it is recommended to proceed according to German guidelines and regulations.**
- **A competent person must be present on site during scaffolding operations.**

\* Valid in Germany: Regulations for Occupational Health and Safety on Construction Sites 30 (RAB 30).

\*\* Instructions are given by the contractor themselves or a competent person selected by them.

## Product description

The PERI UP Flex Stairs 100 and 125 with Deck UDG-2 are based on the PERI UP Flex modular scaffolding. The PERI UP Flex Stairs 100 and 125 are used to reach elevated access points, e.g. to buildings or scaffolding. In addition, the PERI UP Flex Staircases 100 and 125 also allow larger load classes in the basic scaffold as passage decks are no longer required in the basic scaffold. Access takes place by means of the PERI UP Flex Staircases 100 and 125.

### Clear step width between the guardrails

- Steps UAR 100: 84 cm
- Steps UAR 125: 109 cm

### Step width

- Steps UAR 100: 104 cm
- Steps UAR 125: 129 cm

Storey height 200 cm

### Ground plan dimensions

Stair tower with Steps 100:  
Width x (landing platform + step + landing platform)  
 $200 \times (100 + 250 + 100) =$   
 $200 \times 450 \text{ cm}$

Stair tower with Steps 125:  
Width x (landing platform + step + landing platform)  
 $250 \times (125 + 250 + 125) =$   
 $250 \times 500 \text{ cm}$

### Permissible live load

Stairs and decks: 3.0 kN/m<sup>2</sup>  
Steps: 2.4 kN  
Entire construction: 40.0 kN uniformly distributed across all standards or 2.0 kN/m<sup>2</sup> across 20 linear metres for Staircase 100 and across 16 linear metres for Staircase 125.

### Wind loads according to EN 12810 / 12811 and NF P 93-522

- Working wind load:  
dynamic pressure  $q = 0.2 \text{ kN/m}^2$
- max. wind for heights:
  - 0 m:  $q = 0.6 \text{ kN/m}^2$
  - 24 m:  $q = 0.77 \text{ kN/m}^2$
  - 50 m:  $q = 0.87 \text{ kN/m}^2$

Wind load is calculated with an exposure-time factor of  $\psi = 0.7$ , which assumes a maximum exposure time of 2 years.

### Technical data

Horizontal equivalent load: 6% of the live loads.

### Standard configuration

- Flight of stairs corresponds to class B in accordance with EN 12811, Part 1.
- Covers stair towers with alternating staircase units with assembly heights from 2.0 m to max. 50.0 m for Staircase 100 and 40.0 m for Staircase 125 together with associated anchoring.
- Fulfils requirements for stair towers according to Employer's Liability Insurance Association Regulations BGR 113 "Staircases for Construction Work".

### Intended use

PERI products have been designed for exclusive use in the industrial and commercial sectors only by suitably trained personnel.

## Cleaning and maintenance instructions

Clean the scaffold components after each use to maintain the value and usability of the PERI products over the long term.

Some repair work may also be inevitable due to the tough working conditions.



The contractor must ensure that the personal protective equipment required for cleaning, maintenance and repair work, e.g.

- safety helmet,
- safety shoes,
- safety gloves,
- safety goggles,

is available and used as intended.

The following points should help to keep cleaning and maintenance costs as low as possible.

Cleaning tools must be adapted to the respective surfaces of the components so that they are not damaged.

Mechanical components, e.g. spindles, must be cleaned of dirt or concrete residue before and after use, and then greased with a suitable lubricant.

Provide suitable support for the components during cleaning so that no unintentional change in their position is possible.

Do not clean components suspended on crane lifting gear.

Any repairs to PERI products are to be carried out by PERI qualified personnel only.

## Information regarding relocation by crane

The PERI UP scaffold system is also suitable for hoisting operations involving cranes.

However, the displacement of the scaffold is not part of these assembly instructions.

The appropriate attachment points and the size of the relocation units should always be calculated on a project-specific basis.

Only vertical crane transportation is permitted. Do not assemble scaffolds horizontally and then erect them. Exceptions are described in the applicable Instructions for Assembly and Use.

Before moving the crane, it must always be ensured that:

- all base spindle locks have been fitted,
- all standard joints are securely connected to one another,
- all deck levels have additional bracing using horizontal ledgers,
- all wedges have been securely fixed in place using a hammer,
- all locks against lifting are engaged,
- all guardrails are at their end position,
- In strong winds, the Toe Boards UPY and the Toe Boards UPF must be additionally secured.
- Do not stand under suspended loads, guide the scaffolding with ropes.

## Additional technical documentation

- Approval:
  - Z-8.22-863 PERI UP Flex Module System
- Assembly Instructions:
  - PERI UP Scaffolding Kit core components
- User information:
  - User information for pallets and stacking devices
- Brochure:
  - PERI UP Access Technology

---

## Instructions for Use

Use in a way not intended, deviating from the standard configuration or the intended use according to the Instructions for Assembly and Use, represents an application with a potential safety risk, e.g. risk of falling.

Deviations from the standard configuration must be verified for the application by means of separate strength and stability calculations (Industrial Safety Regulation Appendix 1, No. 3.2.1) and explicitly reflected in the assembly instructions.

All components listed in the program overview may be used for assembly. Other components are not permitted. Exceptions are named, or must be planned and verified on a project-specific basis.

The use of other products and spare parts is not allowed. Changes to PERI components are not permitted.

The system described in these Instructions for Assembly and Use may contain patent-protected components.

## Cross-system



### Safety instructions apply to all service life phases of the system.

#### General

The contractor must ensure that the Instructions for Assembly and Use supplied by PERI are available at all times and understood by the site personnel.

These assembly instructions can be used as the basis for preparing the risk assessment. The risk assessment is compiled by the contractor. The assembly instructions do not replace the risk assessment!

Refer to and comply with the safety instructions and permissible loads.

For the application and inspection of PERI products, the current safety regulations and guidelines valid in the respective countries must be observed.

Materials and working areas are to be inspected before each use and assembly for:

- damage,
- stability and
- functional correctness.

Damaged components must be exchanged immediately on site and may no longer be used.

Safety components are to be removed only when they are no longer required.

When on slab formwork, scaffolds and working platforms:

- do not jump,
- do not run,
- do not drop anything from or onto it.

■ Components provided by the contractor must comply with the characteristics stipulated in these Instructions for Assembly and Use and all applicable laws and standards. Unless otherwise indicated, the following applies in particular:

- timber components: strength class C24 for solid wood according to EN 338.
- scaffold tubes: galvanised steel tubing with minimum dimensions  $\varnothing 48.3 \times 3.2$  mm according to EN 12811-1:2003 4.2.1.2.
- scaffold tube couplings according to EN 74-1 and EN 74-2.

Deviations from the standard configuration are only permitted after a further risk assessment has been carried out by the contractor.

Appropriate measures for working and operational safety, as well as stability, are defined on the basis of this risk assessment.

Corresponding proof of stability can be provided by PERI on request, if the risk assessment and resulting measures to be implemented are made available.

Before and after exceptional occurrences that may have an adverse effect on the safety of the scaffold system, the contractor must immediately

- produce another risk assessment and make use of its results to take suitable steps to guarantee the stability of the scaffold system,
- arrange for an extraordinary inspection to be carried out by a competent person qualified to do so. The aim of this inspection is to identify and rectify any damage in good time in order to guarantee safe use of the scaffold system.

Exceptional events could be:

- accidents,
- long periods of non-use,
- natural events, e.g. heavy rainfall, icing, heavy snowfall, storms or earthquakes.

## Assembly, modification and dismantling work

Assembly, modification or dismantling of scaffold systems may only be carried out by qualified persons under the supervision of a competent person. The qualified personnel must have received appropriate training for the work to be carried out with regard to specific risks and dangers.

On the basis of the risk assessment and the applicable Instructions for Assembly and Use, the contractor must draw up assembly instructions to guarantee safe assembly, modification and dismantling of the scaffold system.

Before initial use, the safe functioning of the scaffold must be checked by a person qualified to carry out the inspection. The results of the inspection must be documented in an inspection log.



The contractor must ensure that the personal protective equipment required for the assembly, modification or dismantling of the scaffold system, e.g.

- safety helmet,
- safety shoes,
- safety gloves,
- safety goggles,

is available and used as intended.

Comply with the respective assembly descriptions and safety instructions when making modifications or additions to the scaffolding.



If personal protective equipment against falling from a height (PPE) is required or specified in local regulations, the contractor must determine appropriate attachment points on the basis of the risk assessment.

The PPE against falling to be used is determined by the contractor.

For technically possible attachment points, see Section "Attachment points in the system" on page 15.

The contractor must

- provide safe working areas for site personnel, which are to be reached through the provision of safe access ways. Danger zones must be cordoned off and clearly marked.
- guarantee stability during all stages of construction, in particular during assembly, modification and dismantling operations.
- ensure and demonstrate that all loads that occur are safely transferred.

## Use

Every contractor who uses or allows the scaffold systems to be used, is responsible for ensuring that the equipment is in good condition.

If the scaffold system is used successively or at the same time by several contractors, the health and safety coordinator must point out any possible mutual hazards and all work must then be coordinated.

When scaffolds are used in publicly accessible areas,

- measures to prevent unauthorised use, e.g. enclosure of access areas, must be taken.
- Take measures to prevent injuries caused by impacts with protruding components, e.g. assembly of protective components.

Always keep the contact surfaces of the scaffold free of dirt, objects, snow and ice.

Close off the scaffold in extreme weather conditions.

## System-specific

The load-distributing support used, such as planking, must match the respective substrate. If multiple layers are required, planks are to be arranged crosswise.

It must be ensured that the scaffolding cannot shift in a horizontal direction, irrespective of what substrate is being used.

Close access hatches immediately after use.

Couplings with screw closures must be tightened with 50 Nm. This corresponds to a force of 20 kg using a lever arm length of 25 cm.

Secure the wedges with a jarring blow using a 500 g hammer.

## Anchoring

Anchoring forces, position of the anchoring and reaction forces are provided in Section B3.

The enclosure of the scaffolding or mounting of additional surfaces exposed to the wind changes the stability and must be calculated separately. If necessary, additional measures must be implemented.

Anchoring must be installed progressively with the erection of the scaffold assembly.

The anchoring forces must be transferred into sufficiently load-bearing anchorage via wall ties and fixing materials e.g. the building.

## Checking the anchoring

The anchoring and its components must be inspected by a qualified person nominated by the scaffolding contractor.

Load tests must be carried out at the place of use.

Load tests are to be carried out using suitable test equipment.

The test load must be 1.2 times higher than the required anchoring force  $F_a$ .

The scope of testing must, however, include a minimum of 5 load tests for all dowels used for concrete anchoring bases (at least 10 %) and for other building materials (at least 30 %).



**Ensure that the relevant national guidelines and regulations are complied with!**

## Storage and transportation

Store and transport components in such a way that no unintentional change in their position is possible. Detach lifting accessories and slings from the lowered components only if they are in a stable position and no unintentional change is possible.

Do not drop the components.

Use PERI lifting accessories and slings and only those load-bearing points provided on the component.

During the moving procedure:

- ensure that components are picked up and set down so that unintentional falling over, falling apart, sliding, falling down or rolling is avoided.
- no persons are allowed to remain under the suspended load.

Always guide pre-assembled scaffold bays, scaffolding units or scaffolding sections with ropes when moving them by crane.

The access areas on the construction site must be free of obstacles and tripping hazards, as well as being slip-resistant.

For transportation, the substrate must have sufficient load-bearing capacity.

Use original PERI storage and transport systems, e.g. crate pallets, pallets or stacking devices.



## Inspection, handover and use

The erected scaffold must be inspected by the scaffolding contractor in order to determine that assembly has been carried out correctly. If the contractor is convinced that the scaffold has been correctly erected, it can then be handed over to the user.

It is advisable to carry out the handover with the user and, for example, to document this in a written report.



**During the handover, the scaffolding contractor must advise the user of any possible risks involved with non-intended use and his obligation to provide adequate prevention against risk and danger!**

- Put up safety and warning signs at the scaffold access point.
- Handover of a usage plan.



**The contractor who uses the scaffolds, must ensure that the scaffolding is in good condition and not arbitrarily altered in any way. In this respect, the qualified specialists must be instructed that if changes have obviously been made during use, these must be reported to the respective qualified and competent person.**

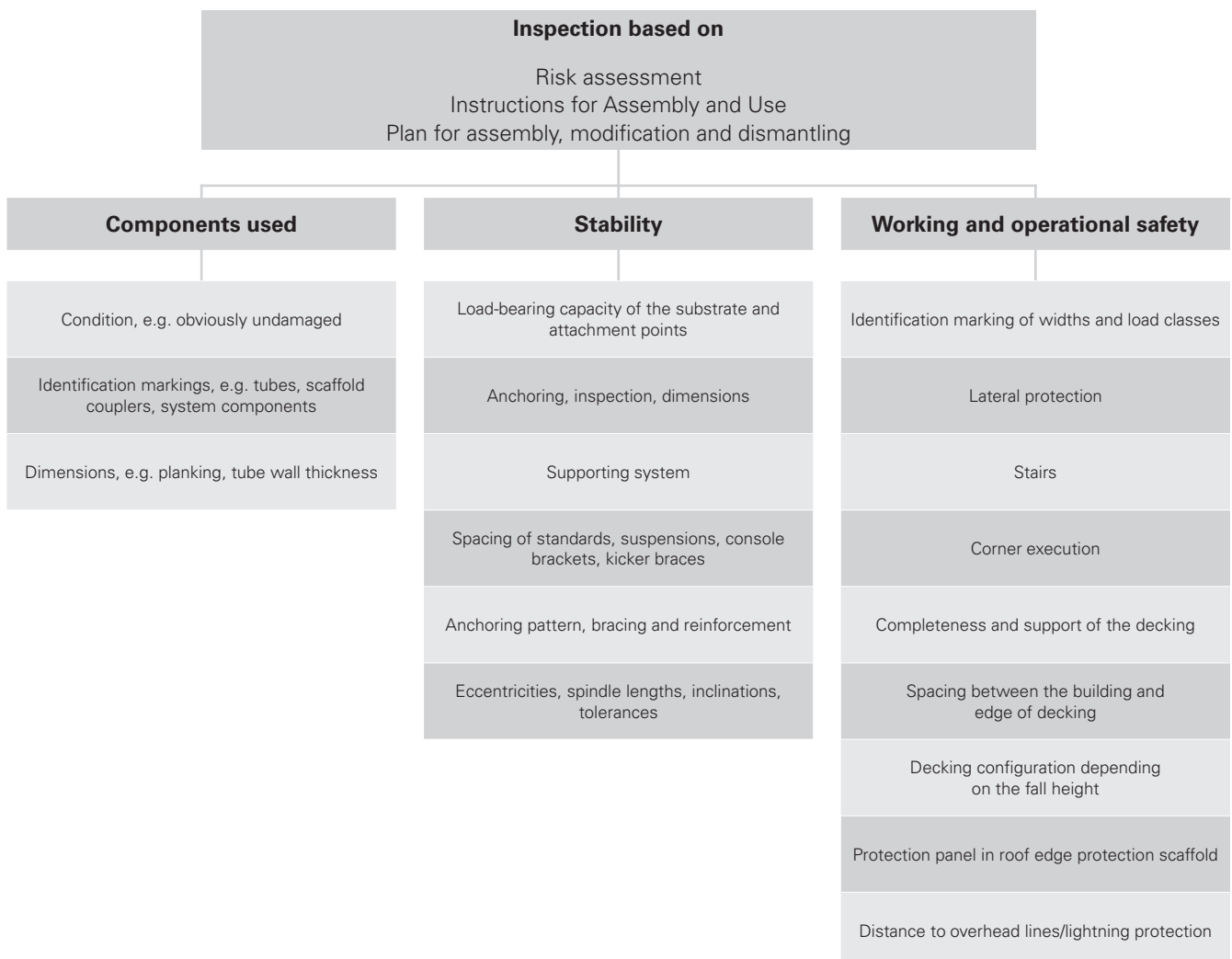

Source: based on TRBS 2121 Part 1

## Verified attachment points

Certain assembly situations could occur that require the use of personal protective equipment (PPE) to prevent falling from a height. For this, the following verified attachment points must be used:

### All attachment points require the following:

- The standing height can be a maximum of one level above the last anchoring position.
- At least one anchoring layer must always be present, or the scaffold is verified to be free-standing and the tilt resistance is guaranteed.

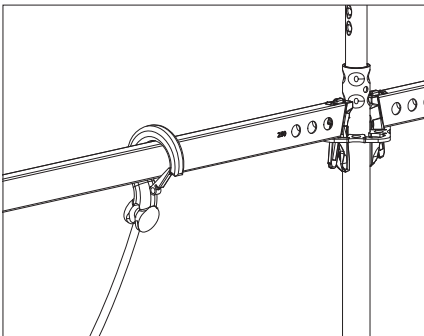

Fig. M.01

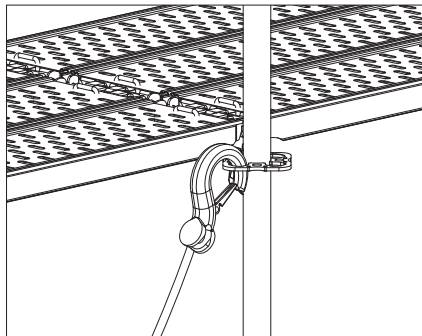

Fig. M.02

### Horizontal ledger

Attachment point:

Each Horizontal Ledger UH Plus or UH-2

- which is freely accessible for the lifting gear
- and is installed at a maximum height of 1.0 m above the deck level.
- and which is wedged on two rosettes of 2 standards.  
The standards must be at least 2 m long.

### Rosette

Attachment point:

Each rosette that is integrated in the base scaffold. See rules and regulations on the right.

## Attachment points in the system



Each specified attachment point is intended for securing only one person!

### General information

- The use of personal protective equipment to prevent falling from a height is regulated in the project-related risk assessment that has been prepared by the contractor (user).
- When using personal protective equipment to prevent falling from a height, all valid standards and safety regulations are to be taken into consideration by the contractor.
- Each scaffold assembly is to be secured against tipping by the user.
- The application concerns assembly, reconstruction and dismantling.

### Requirements

- The scaffold assembly underneath the final assembly level is complete. This means, all ledgers and diagonal bracing have been installed and the decking is in place as the topmost assembly level.
- The joints of the topmost standards must lie underneath the last assembly level.

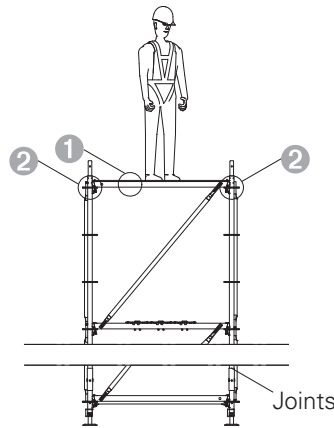

Fig. M.03

### Attachment points

Standard ends approx. 2 m below the assembly level:

- each horizontal ledger in the assembly level ①,
- each rosette in the assembly level ②.

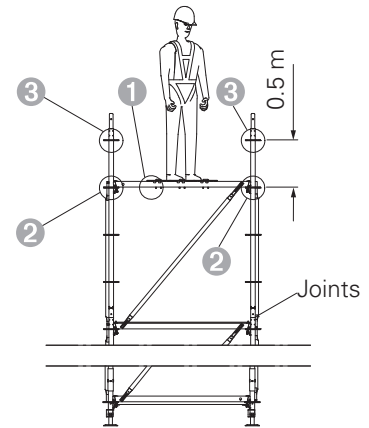

Fig. M.04

### Attachment points

Standard ends approx. 1.5 m below the assembly level:

- each horizontal ledger in the assembly level ①,
- each rosette up to max. 0.5 m above the last assembly level ②, ③.

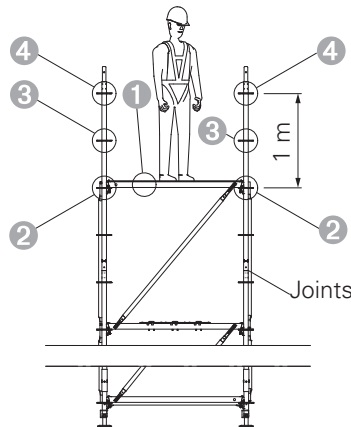

Fig. M.05

### Attachment points

Standard ends approx. 1 m below the assembly level:

- each horizontal ledger in the assembly level ①,
- each rosette up to max. 1.0 m above the last assembly level ② ③ ④.

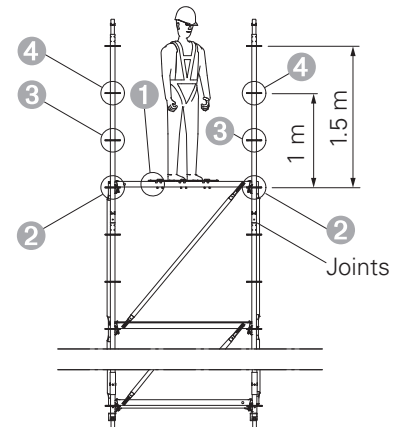

Fig. M.06

### Attachment points

Standard ends approx. 0.5 m below the assembly level:

- each horizontal ledger in the assembly level ①,
- each rosette up to max. 1.0 m above the last assembly level ② ③ ④.

## General



For a basic description of the assembly of scaffold components in the PERI UP system, see the PERI UP assembly instructions – core components of scaffolding kit.

Comply with the prescribed assembly sequences!

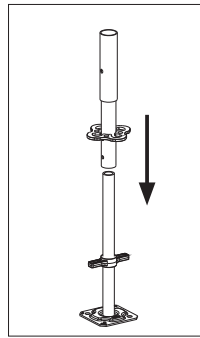

Fig. A1.01

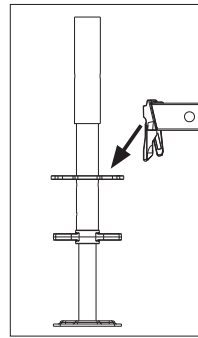

Fig. A1.02

## Load-distributing supports



Use load-distributing supports subject to the load-bearing capacity of the substrate.

■ Supports and base plates must make full-face contact with the substrate.

## Base level

### Components

1	Base Spindle UJB	10x
2	Base Standard UVB 25	10x
3	Horizontal Ledger UH-2 250	1x
4	Horizontal Ledger UH-2 200	2x
5	Horizontal Ledger UH-2 100	8x
32	Steel Deck UDG-2 25x200	4x

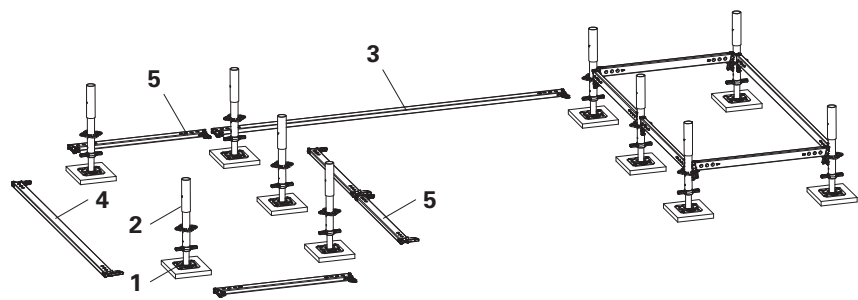

Fig. A1.03

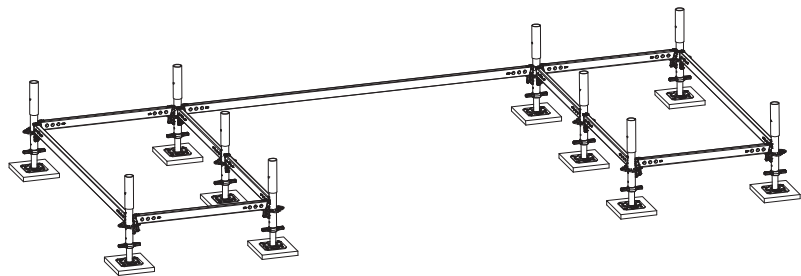

Fig. A1.04

### Assembly

Start the assembly process at the highest point of the terrain (= the least height compensation).

1. Set out Horizontal Ledger UH-2 (**3 + 4 + 5**).
2. Set out the load-distributing supports.
3. Set up the Base Spindles UJB (**1**).
4. Fit Base Standards UVB 25 (**2**) onto the base spindles.
5. Connect the base standards to the horizontal ledgers. Do not hammer the wedges in yet. (Fig. A1.03, Fig. A1.04)

## Installing an assembly aid

### Assembly aid components

<b>3a</b>	Horizontal Ledger UH-2 250	2x
<b>32a</b>	Steel Deck UDG-2 25x200	2x
<b>34a</b>	Steel Deck UDG-2 25x250	2x

### Assembly

1. Fit two more Horizontal Ledgers UH-2 250 (**3a**) as assembly aids. (Fig. A1.05)
2. The base level is aligned horizontally by accurately adjusting the Base Spindles UJB (**1**). Maximum spindle length 17 cm. (Fig. A1.05)
3. Securely fix the wedges of Horizontal Ledgers UH-2 (**3 + 4 + 5**) in position with a jarring blow using a hammer.
4. Place Steel Decks UDG-2 200 (**32 + 32a**) on the horizontal ledgers (**5**) one after the other. (Fig. A1.06)
3. Lift locks (**32.1**) drop beneath the crossbar and secure the deck. (Fig. A1.07a – Fig. A1.07d)
  - The deck is now installed.
  - The base level is now installed.

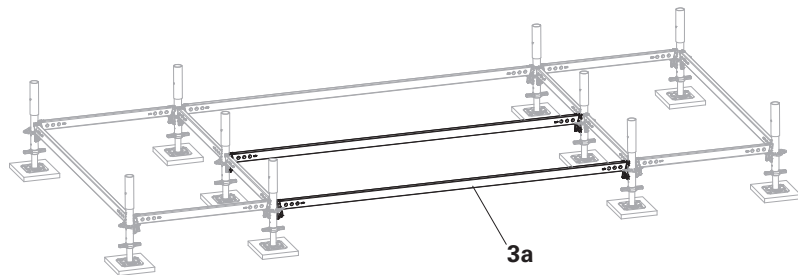

Fig. A1.05

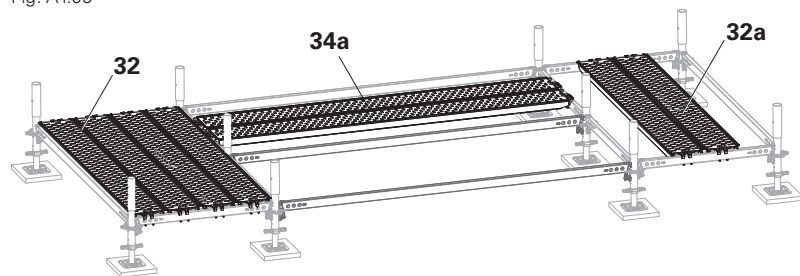

Fig. A1.06



Have all lift locks (**32.1**) on the deck dropped beneath the crossbar? If not, lift the deck slightly and let it drop into position or operate the lift lock manually. (Fig. A1.07d)



Depending on the requirements or national regulations, fit additional decks linings as assembly aids.

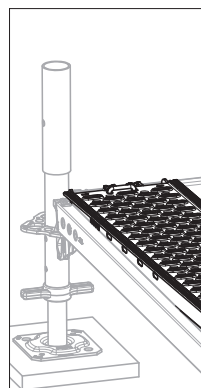

Fig. A1.07a

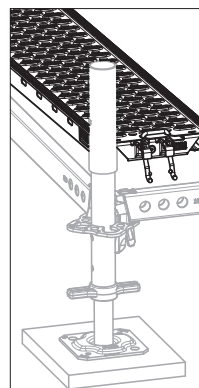

Fig. A1.07b

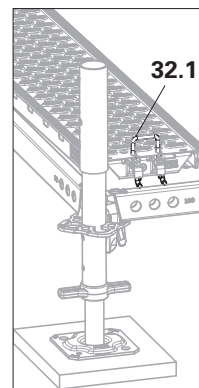

Fig. A1.07c

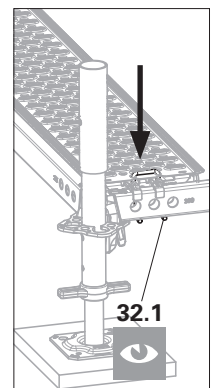

Fig. A1.07d

## Standards and ledgers, guardrail in advance

### Components

<b>7</b> Standard UVR-2 300	10x
<b>4</b> Horizontal Ledger UH-2 200	4x
<b>5</b> Horizontal Ledger UH-2 100	7x
<b>41</b> Node Brace UBK-2 250/200	2x

### Assembly

- Fit all Standards UVR-2 300 (**7**) apart from two pieces. (Fig. A2.01)  
Fit Standards UVR-2 with holes lined up so that the locking pins can be easily installed. (Fig. A2.04)
- Fit Node Brace UBK-2 (**41**) into the upper rosettes of the two remaining standards (**7a**).  
– Fit the node brace into the brace adapters of the rosettes. (Fig. A2.02a)
- Fit the standards (**7a**) with pre-assembled node braces (**41**) in such a way that the node braces are within the stair frame. (Fig. A2.02)

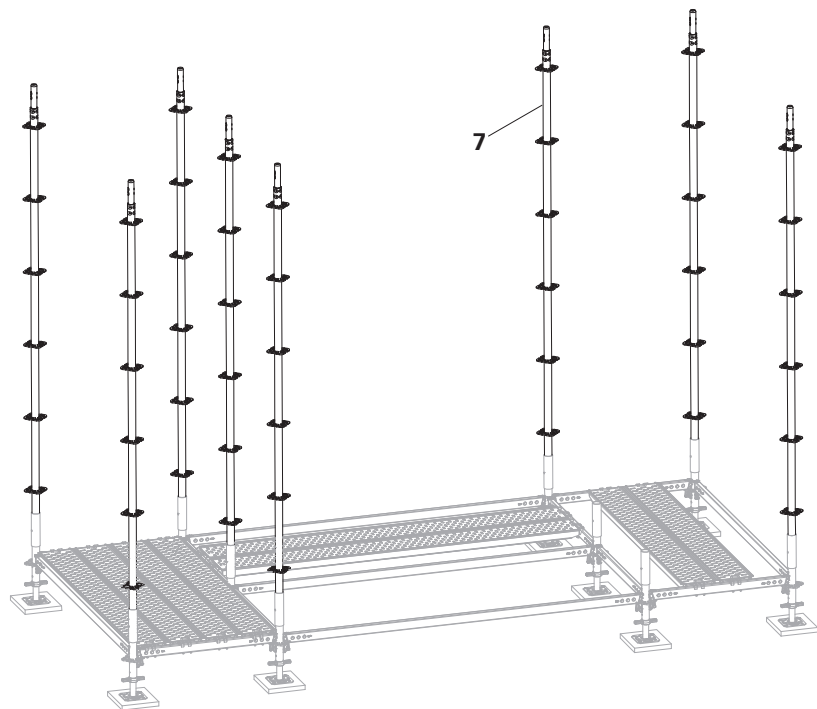

Fig. A2.01

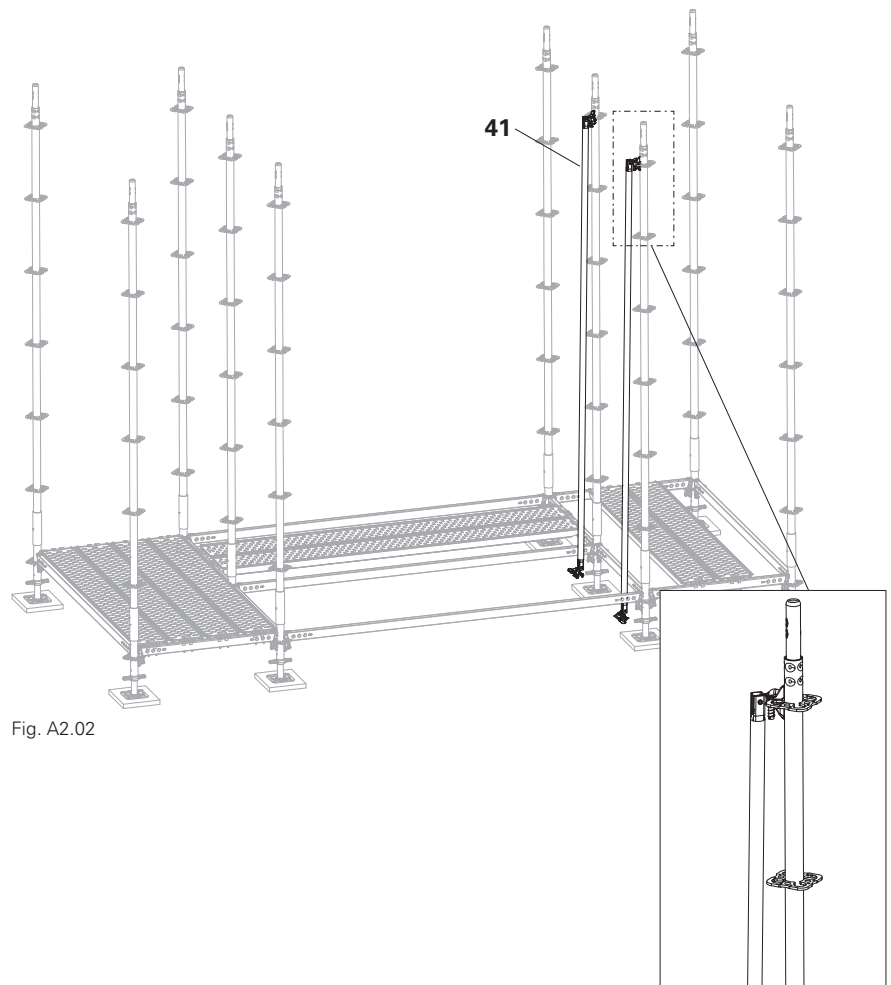

Fig. A2.02

Fig. A2.02a

4. Fit Node Brace UBK-2 (**41**) into the bottom rosettes.  
(Fig. A2.03 to Fig. A2.03b)
5. Hook in the Horizontal Ledgers UH-2 200 and UH-2 100 (**4 + 5**) and knock them in tight.

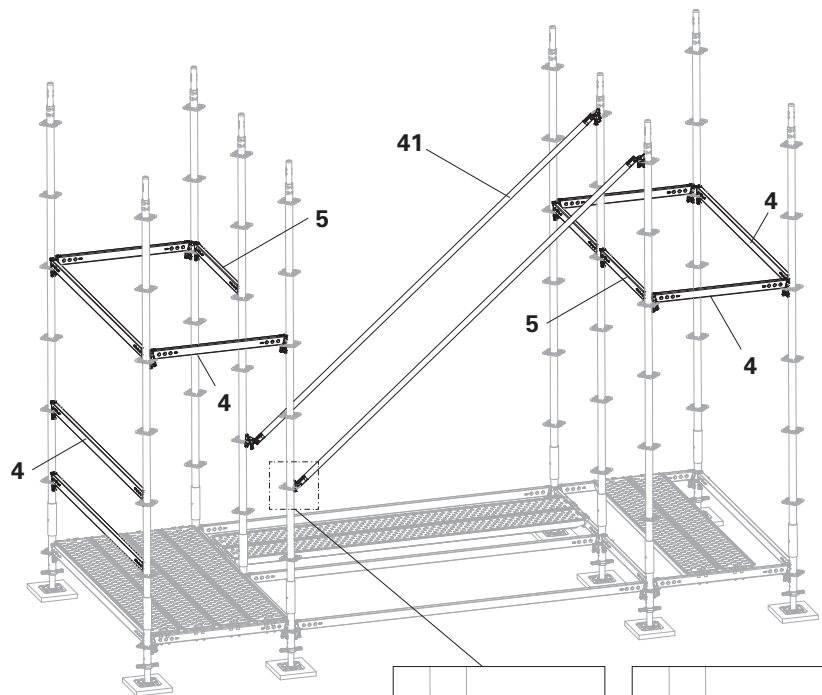

Fig. A2.03

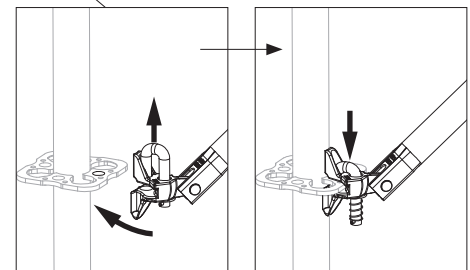

Fig. A2.03a

Fig. A2.03b

## Preparing for hoisting operations involving cranes



All standards or base standards can be secured with a locking pin  $\text{Ø } 48/57$  (**14**) if the steel staircase is to be lifted, e.g. with a crane, in order to move it.

### Components

<b>58</b> Spindle Locking UJS	10x
<b>14</b> Locking Pin $\text{Ø } 48/57$	10x

### Assembly

1. Secure Base Spindles UJB (**1**) with Spindle Locking UJS (**58**).
2. Tightly connect Base Standards UVB and Standards UVR-2 using locking pins  $\text{Ø } 48/57$  (**14**). (Fig. A2.04)

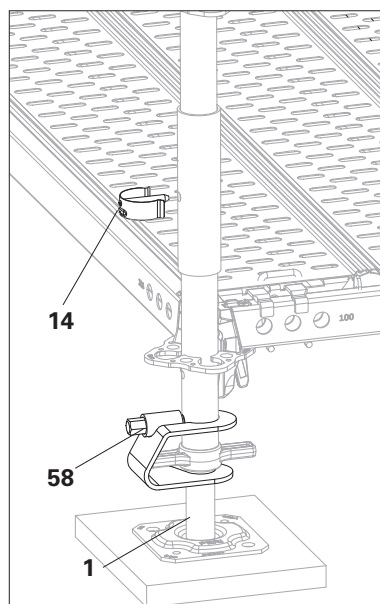

Fig. A2.04



Spindle out the Base Spindle UJB by at least 17 cm.

This is the only way to ensure a tension-proof connection between the Base Standard UVB and the Top Standard UVH-2 with locking pins. (Fig. A2.04a)

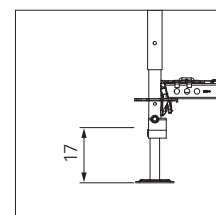

Fig. A2.04a

## Decks and braces

### Components

<b>32</b>	Steel Deck UDG-2 25x200	4x
<b>42</b>	Ledger Brace UBL 200/200	1x

### Assembly aid components

<b>32a</b>	Steel Deck UDG-2 25x200	2x
<b>34a</b>	Steel Deck UDG-2 25x250	2x

### Assembly

1. Fit Steel Decks UDG-2 200 (**32**) as a platform.
2. Fit Steel Decks UDG-2 (**32a + 34a**) as an assembly aid. (Fig. A2.05)
3. Insert Ledger Brace UBL (**42**) into the top Horizontal Ledger UH-2 with the mounting finger. (Fig. A2.05a)  
Insert the tilt finger into the hole of the bottom Horizontal Ledger UH-2, turn finger to a transverse position to secure. (Fig. A2.05b)
4. Remove the assembly decks (**32a**) from the level below.  
→The decks and braces are now in place.



All tilt fingers (**42.1**) of the assembly must be transverse after installation of the Ledger Braces UBL and rest on both sides of the hole.



Depending on the requirements or national regulations, fit additional steel decks as assembly aids.

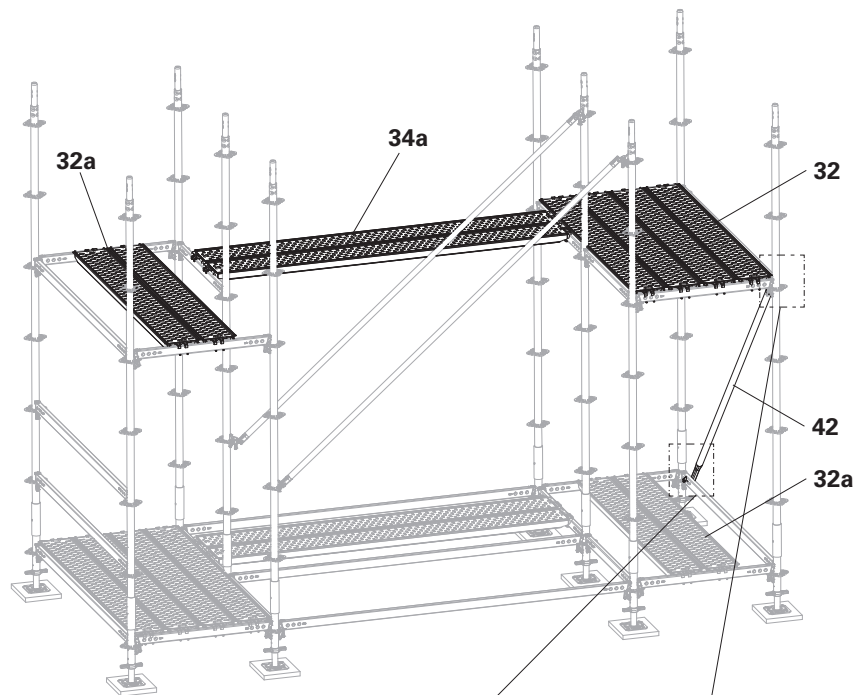

Fig. A2.05

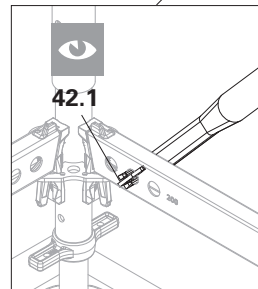

Fig. A2.05b

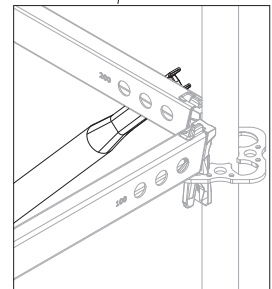

Fig. A2.05a

## Stair stringers

<b>11</b> Stair Stringer UA 250/200	2x
<b>4</b> Horizontal Ledger UH-2 200	2x

### Assembly

1. Remove both Horizontal Ledgers UH-2 250 which were installed as assembly aids (not shown).
  2. Fit the Stair Stringers UA (**11**) into the rosettes of the standards at the top and bottom and fix securely.
  3. Brace with two Horizontal Ledgers UH-2 200 (**4**), secure the wedges. (Fig. A2.06)
- The stair stringers are now installed.

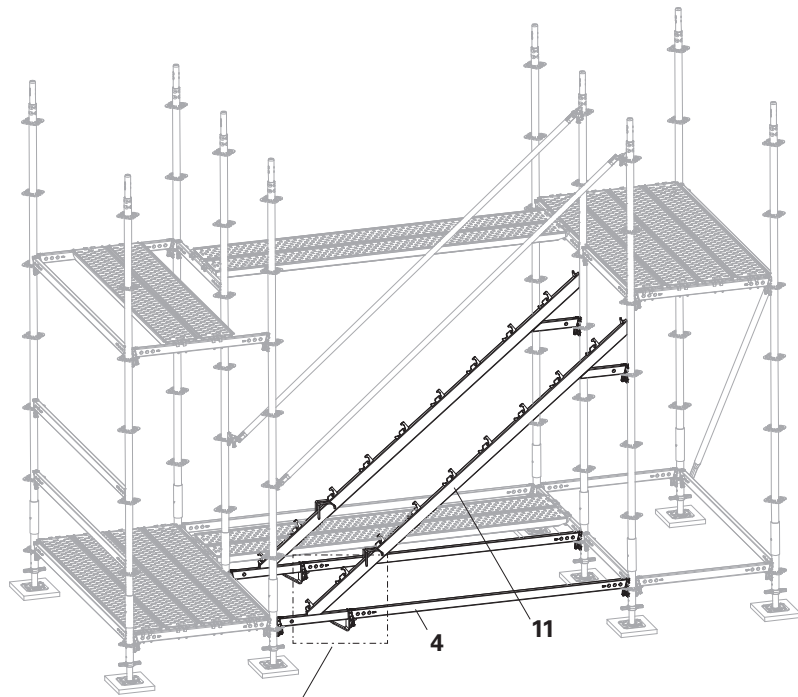

Fig. A2.06

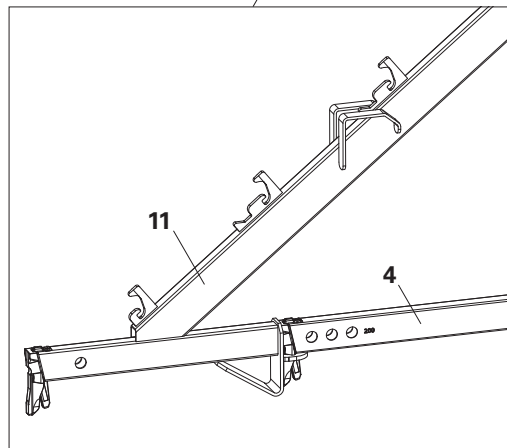

Fig. A2.06a

## Steps

### Components

<b>12</b> Step UAR 100	9x
<b>13</b> End Step UAE 100	1x
<b>31</b> Steel Deck UDG-2 25x100	1x

### First step

#### Assembly:

1. Position Steel Deck UDG-2 100 (**31**) on the Stair Stringers UA (**11**).
2. Tilt the first step (**12**) and place it in the lowest support (**11.1**) of the stair stringers. (Fig. A2.08a)
3. Tilt the step towards the stair stringer and into the upper supports. Make sure that the hooks (**11.2**) engage in the slots (**12.1**) on both sides. (Fig. A2.08b + Fig. A2.08c)



Do the locating hooks (**11.2**) engage in the slots (**12.1**) of the riser? (Fig. A2.08b)

Is the tread resting on top of the stair rail? (Fig. A2.08c)

→The first step is installed.

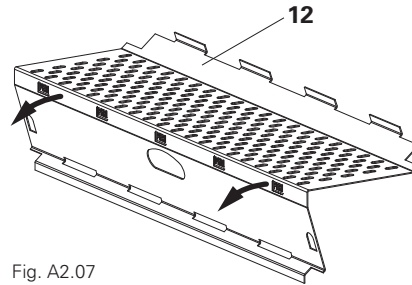

Fig. A2.07

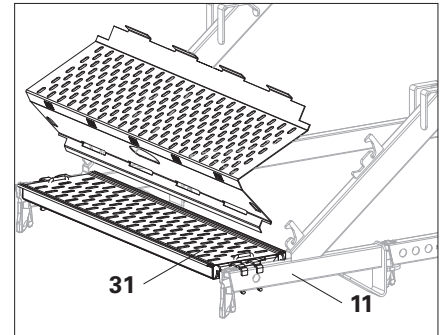

Fig. A2.08a

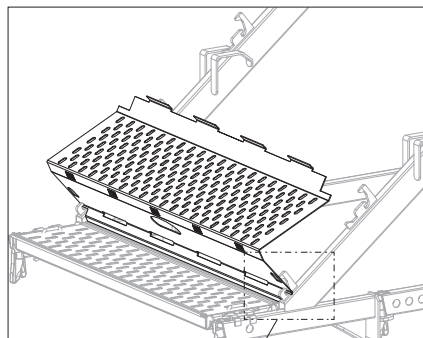

Fig. A2.08b

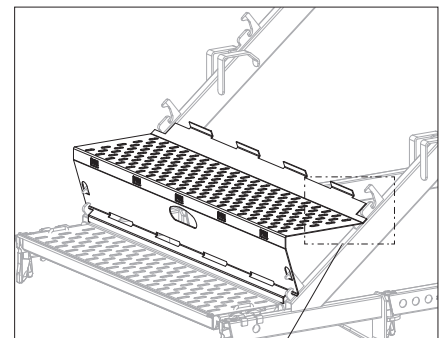
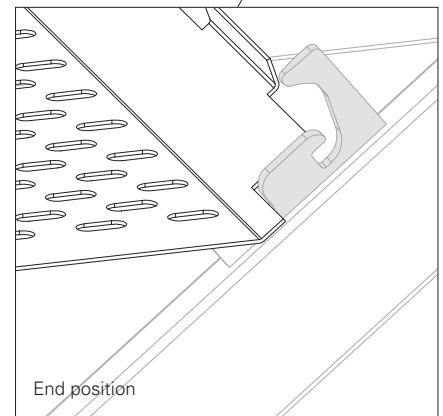
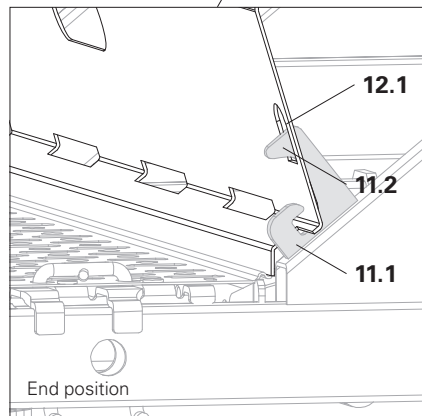

Fig. A2.08c



## Second to last step

### Assembly

1. Position the second step (12) on the first step together with the riser. (Fig. A2.09a) The teeth (12.3) of the preceding step must engage in the slots (12.2) of the riser. (Fig. A2.09b) → The step is resting in the supports (11.1) of the Stair Stringers UA.
2. Tilt the step upwards. → The hook (11.2) engages in the slots (12.1). (Fig. A2.09c + Fig. A2.09d) → The teeth (12.3) of the preceding step slip through the slots (12.2) of the riser and connect both steps. (Fig. A2.09ed + Fig. A2.09fe) → The top of the step rests against the Stair Stringers UA. (Fig. A2.09f)
3. Repeat procedure up to the last step. The uppermost support has a different design. (Fig. A2.10a + Fig. A2.10b)

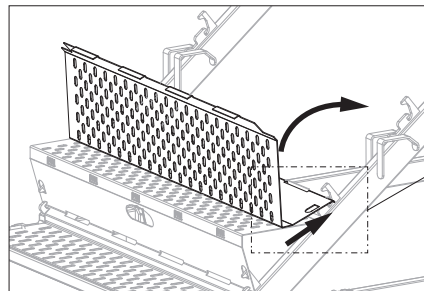
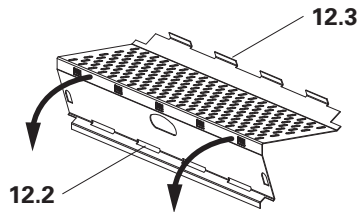

Fig. A2.09a

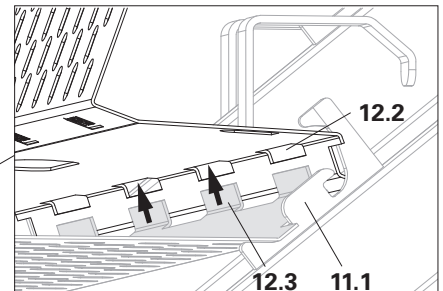

Fig. A2.09b

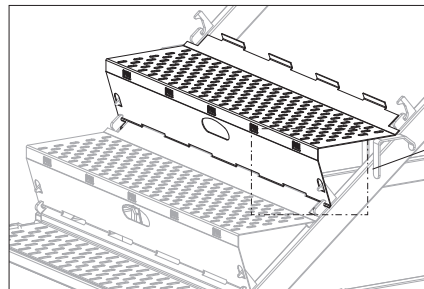

Fig. A2.09c

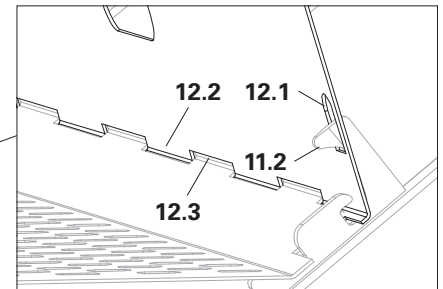

Fig. A2.09d

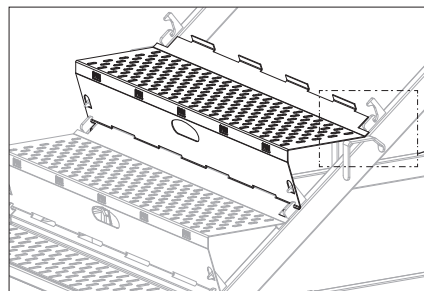

Fig. A2.09e

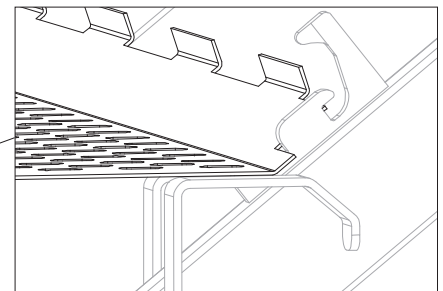

Fig. A2.09f

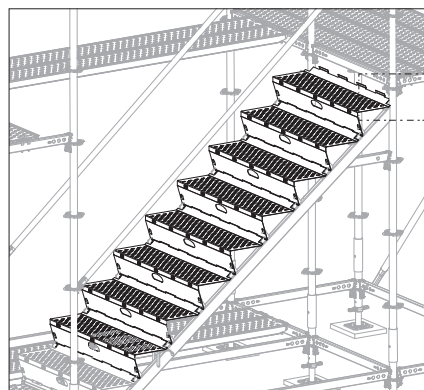

Fig. A2.10a

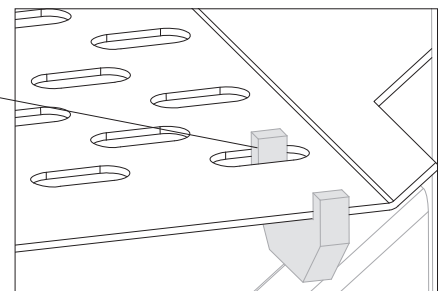

Fig. A2.10b

## End step

### Assembly

→Precondition

At the end step, the screws (13.3) of the lift lock must be level with the inside of the end step.

1. Lift the step installed most recently (12) out of the holder slightly so that it is at an angle. (Fig. A2.11a)
2. Set the End Step UAE (13) down flat on last step (12). (Fig. A2.11b) The teeth (12.3) of the preceding Step UA must engage in the slots (13.2) of the End Step UAE.
3. Fold the End Step UAE upwards (13). The teeth (12.3) of the preceding step slip through the slots (13.2) of the end step and connect both steps. (Fig. A2.11c)
4. Swing the End Step UAE (13) back together with the last step until the End Step UAE (13) can be clipped into the horizontal ledger (5). (Fig. A2.11d + Fig. A2.11e)  
→ The step installed most recently engages in the Stair Stringers UA (11).
5. At the end step: Screw in the screws (13.3) so they act as a lift lock.  
→The staircase is installed

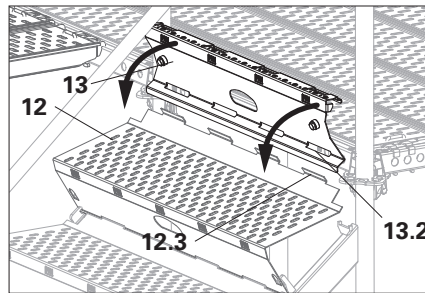

Fig. A2.11a

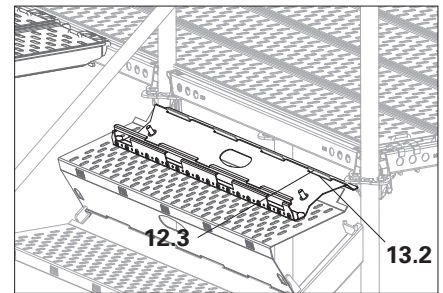

Fig. A2.11b

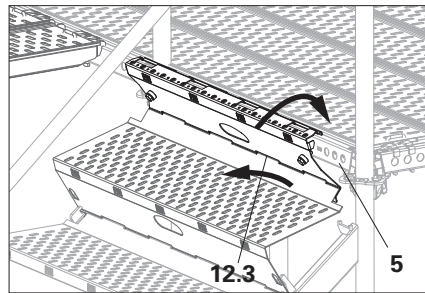

Fig. A2.11c

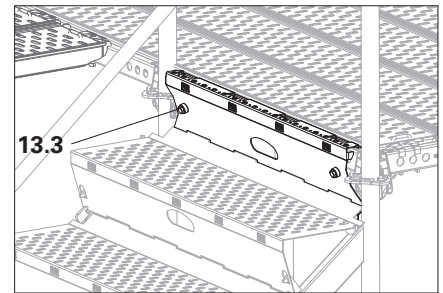

Fig. A2.11d

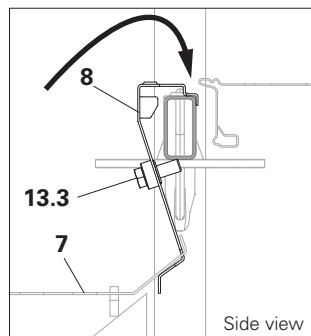

Fig. A2.11e



Is the end step clipped into the horizontal ledger?

Is the end step's lift lock (13.3) working? (Fig. A2.11e)

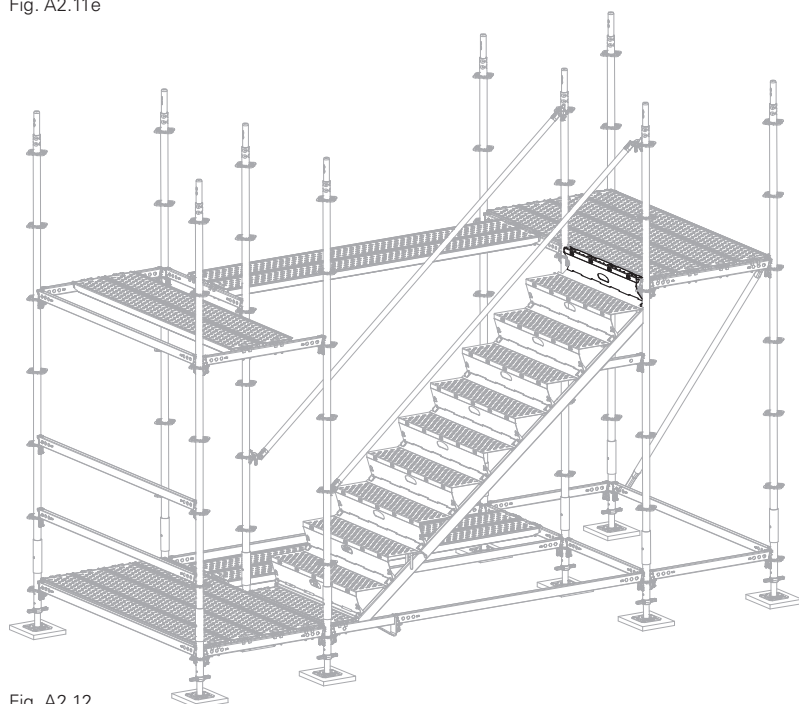

Fig. A2.12

## Bracing

### Components

<b>3</b> Horizontal Ledger UH-2 250	1x
<b>45</b> Ledger Brace UBL-2 250/200	1x

### Assembly:

1. Attach Horizontal Ledger UH-2 250 (**3**) from the stairs, and secure with a blow of the hammer.
2. Insert the Ledger Brace UBL-2 (**45**) into the lower Horizontal Ledger UH-2 (**3a**) using the mounting finger, insert the tilt finger into the hole of the upper Horizontal Ledger UH-2 (**3**) and turn finger to a transverse position to secure. (Fig. A2.13)



Are all tilt gravity pins (**45.1**) of the Ledger Braces UBL in a transverse position and resting on both sides of the hole?

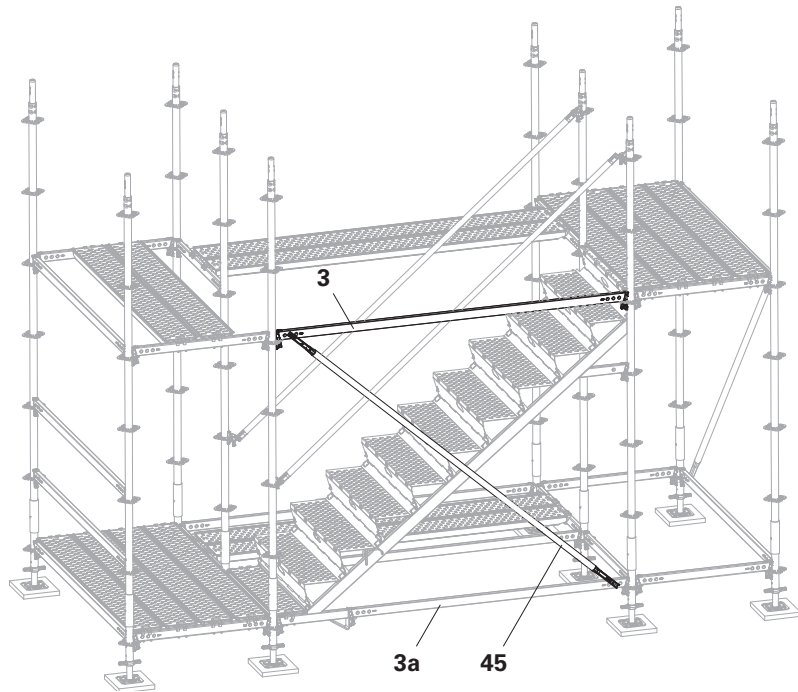

Fig. A2.13

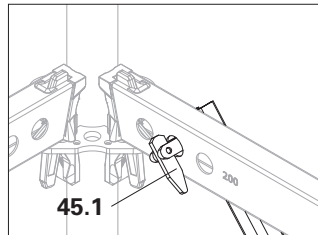

Fig. A2.13a

## Guardrail



### Warning

During assembly, there is no lateral protection on the scaffolding!

A fall can result in serious injuries or even death.

⇒ Use personal protective equipment to prevent falling from a height.

### Components

<b>41</b> Node Brace UBK 250/200	2x
<b>4</b> Horizontal Ledger UH-2 200	2x
<b>5</b> Horizontal Ledger UH-2 100	4x

### Assembly aid components

<b>3a</b> Horizontal Ledger UH-2 250	2x
<b>4a</b> Horizontal Ledger UH-2 200	1x
<b>5a</b> Horizontal Ledger UH-2 100	3x

### Assembly

1. Fit Node Braces UBK (**41**) into the rosettes as an intermediate guardrail.
2. Fit Horizontal Ledgers UH-2 (**4 + 5**) as a landing guardrail.
3. Fit the horizontal ledgers (**3a + 4a + 5a**) as assembly guardrails. (Fig. A2.14)
4. Secure the wedges.  
→ The first flight of stairs is now installed.



Fit additional horizontal ledgers and toe boards as lateral protection if stipulated by the requirements or national regulations.



Replace Horizontal Ledger UH-2 250 (**3a**) with Guardrail Holder EPW and Guardrail Posts EPG. This allows the temporary lateral protection to remain in place until the stair stringers are installed.

See Section "Stair stringers" on page 33.

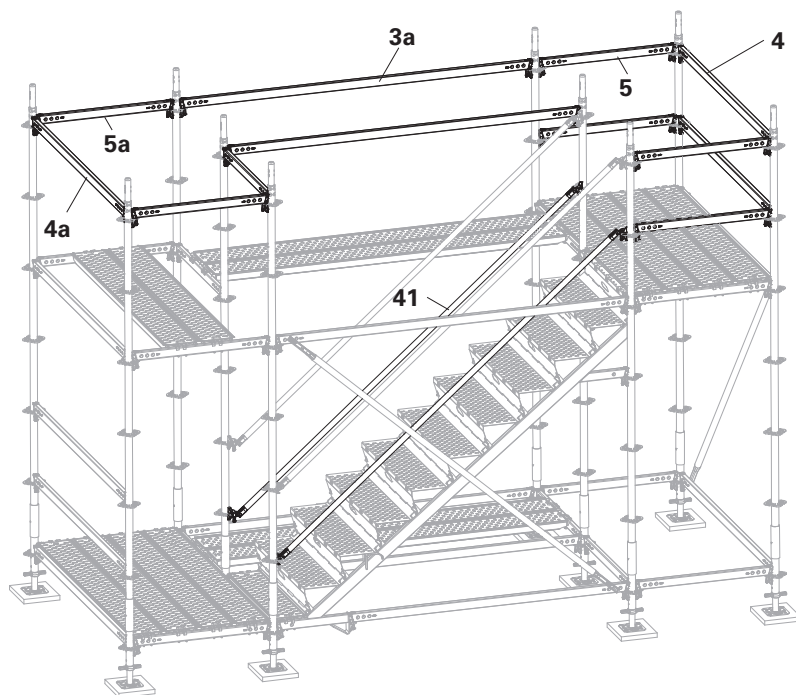

Fig. A2.14

## Landing variants

Landing platforms are available in widths of 100 cm or 125 cm in three variants for Steel Decks UDG-2.

### Staircase 100

Variant 1

UDG-2 25 x 200 lengthwise  
UH-2 outside

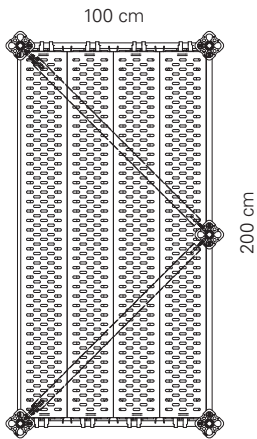
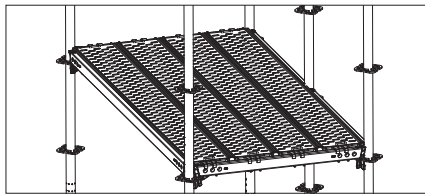

Variant 2

UDG-2 25 x 100 lengthwise  
UHV-2 and UHA-2 outside

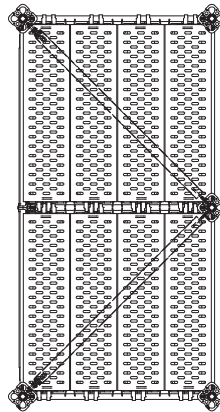
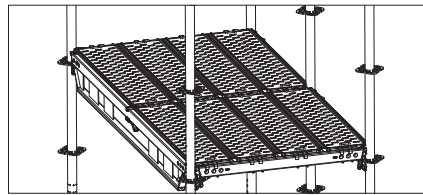

Variant 3

UDG-2 25 x 100 transverse  
UHV-2 outside

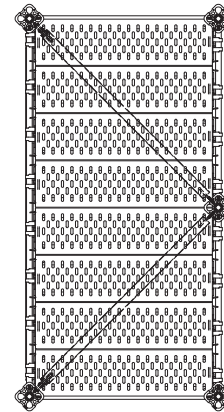
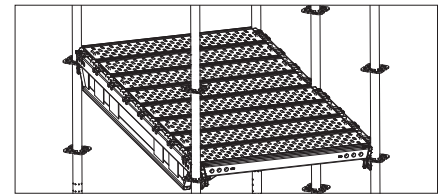

### Staircase 125

Variant 1a

UDG-2 25 x 250 lengthwise  
UH-2 outside

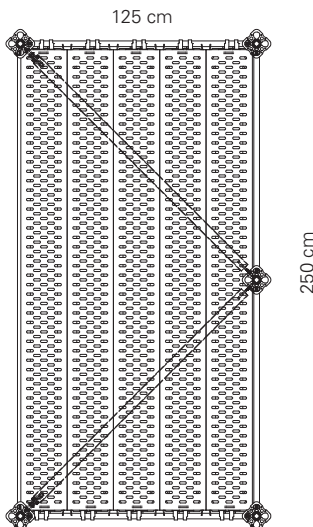

Variant 2a

UDG-2 25 x 125 lengthwise  
UHV-2 and UHA-2 outside

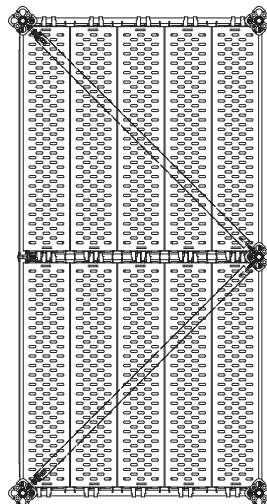

Variant 3a

UDG-2 25 x 125 transverse  
UHV-2 outside

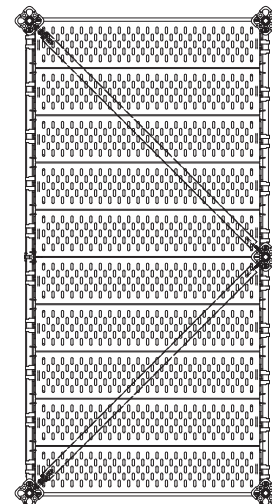

## Standards and ledgers, guardrail in advance

<b>4</b> Horizontal Ledger UH-2 200	2x
<b>5</b> Horizontal Ledger UH-2 100	8x
<b>8</b> Standard UVR-2 200	10x
<b>41</b> Node Brace UBK-2 250/200	2x
<b>52</b> Locking pin Ø 48/57	10x

### Assembly

1. Fit all Standards UVR-2 200 (**8**) apart from two pieces.  
Fit Standards UVR-2 with holes lined up so that the locking pins can be easily installed.
2. Fit Node Braces UBK-2 (**41**) on the standards (**8a**) as described in chapter "A2 First staircase" on page 20 .
4. Hook in the Horizontal Ledgers UH-2 200 and UH-2 100 (**4 + 5**) and knock them in tight. (Fig. A3.01)



All standards or base standards can be secured with a locking pin Ø 48/57 (**52**) if the steel staircase is to be relocated, e.g. with a crane.

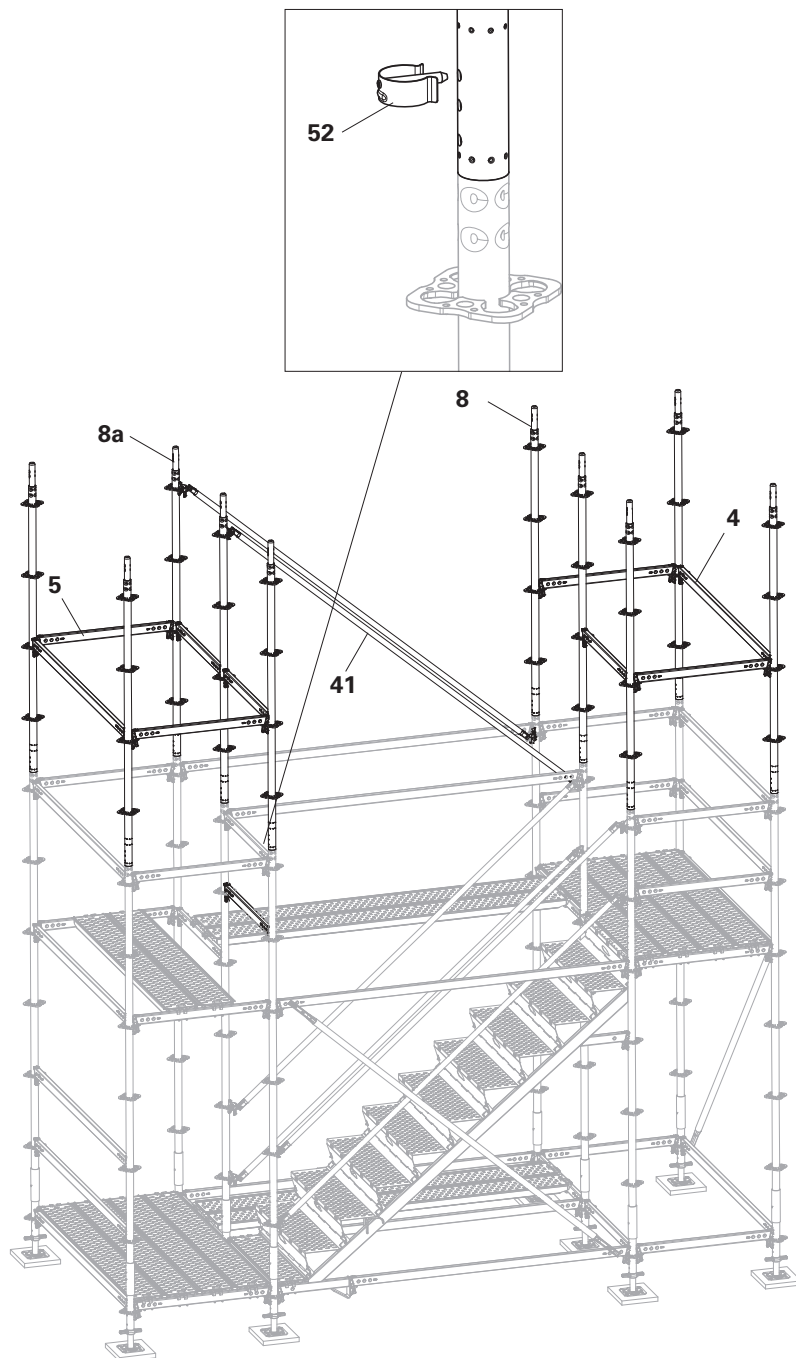

Fig. A3.01

## Decks and braces

### Components

<b>3</b> Horizontal Ledger UH-2 250	2x
<b>32</b> Steel Deck UDG-2 25x200	4x
<b>42</b> Ledger Brace UBL-2 200/200	1x
<b>43</b> Horizontal Brace UBH Flex 250/100	1x
<b>44</b> Horizontal Brace UBH Flex 100/100	4x
<b>45</b> Ledger Brace UBL-2 250/200	1x

### Assembly aid components

<b>32a</b> Steel Deck UDG-2 25x200	2x
<b>34a</b> Steel Deck UDG-2 25x250	2x

### Assembly

From the level immediately below:

1. Fit Steel Decks UDG-2 200 (**32**) and (**32a**). (Fig. A3.02)
2. Fit Steel Decks UDG-2 250 (**34a**).

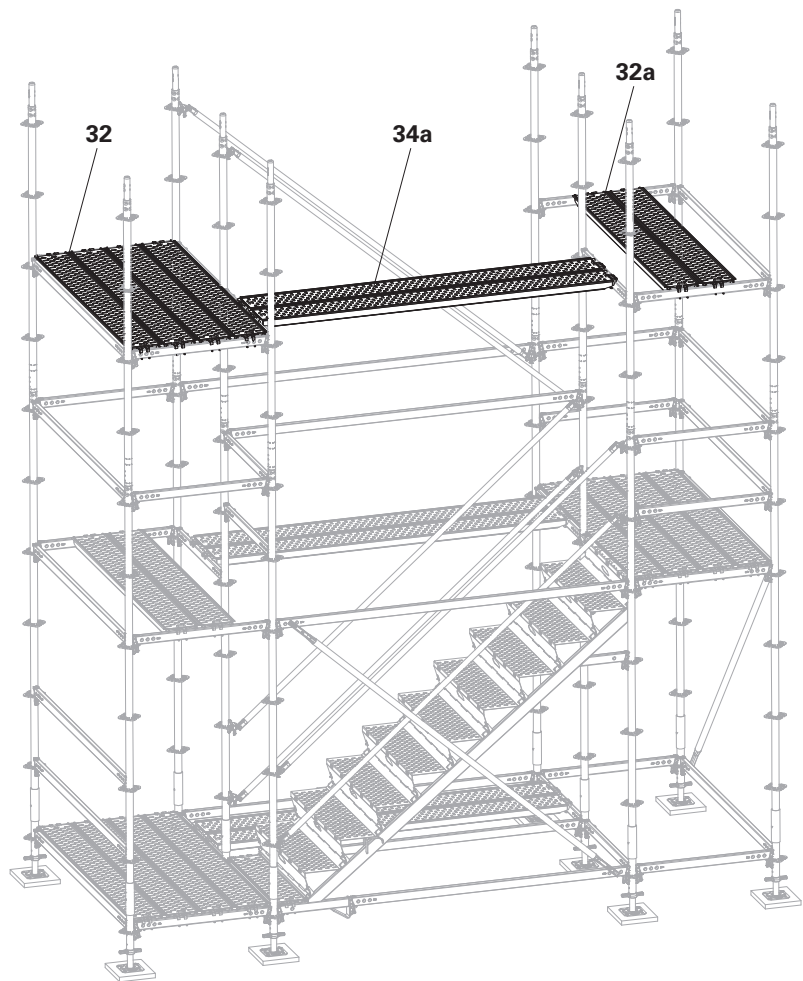

Fig. A3.02

3. Fit Horizontal Ledgers UH-2 250 (3) on the outside of the long sides.
  4. Fit Ledger Brace UBL-2 250/200 (45) on the next level above the staircase.
  5. Fit the Ledger Braces UBL-2 200/200 onto the sides of the platform with the mounting finger at the top and tilt finger at the bottom (42).
- (Fig. A3.03)



Are all tilt gravity pins (45.1) of the Ledger Braces UBL in a transverse position and resting on both sides of the hole? (Fig. A3.03a)

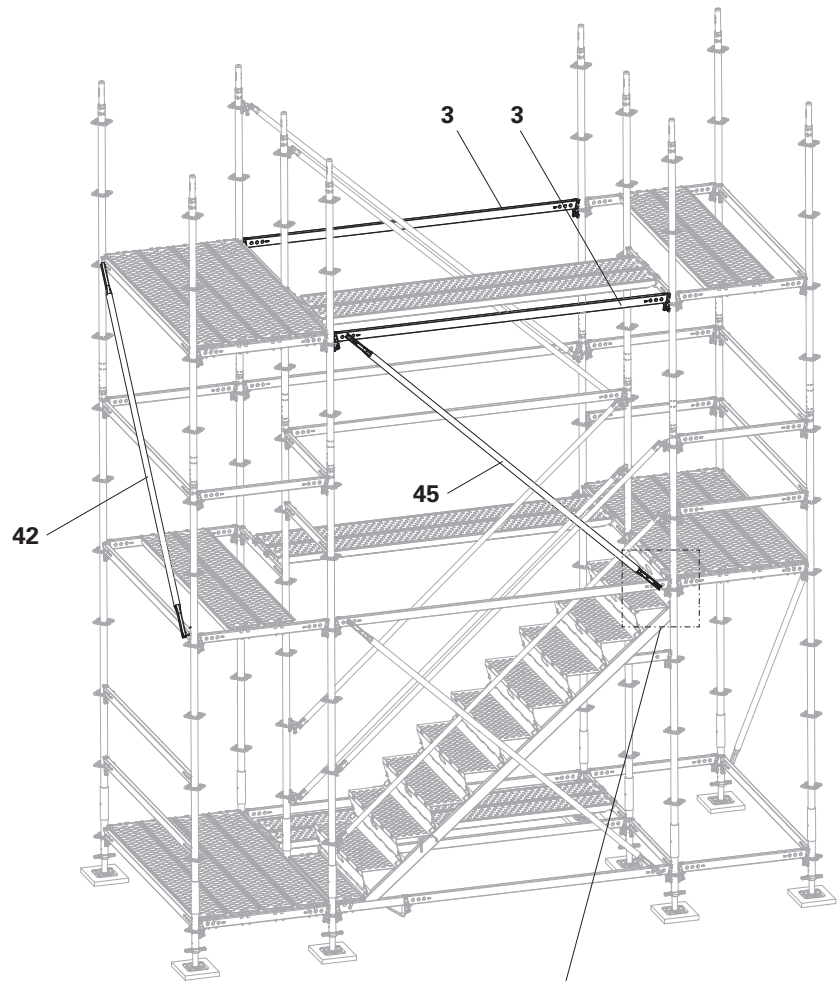

Fig. A3.03

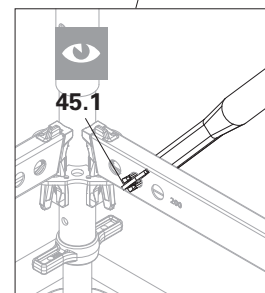

Fig. A3.03a

6. Fit Horizontal Braces UBH (**43 + 44**) beneath the Steel Decks UDG-2 (**32 + 32a + 34**):

- Fit the hook into the round hole of the rosette. (Fig. A3.04a)
  - On the opposite side of the horizontal brace, push the safety catch to the centre position and pull back the slider.
  - Attach the hook from below.
  - Push the slider forwards.
  - Safety catch drops down (Fig. A3.04b)
- The Horizontal Braces UBH are mounted and secured. (Fig. A3.04)

Install the first level of Horizontal Braces UBH at a height of 4.0 m, then at spacings of 4.0 m.



Alternative:

The Horizontal Braces UBH Flex 250/100 and UBH Flex 100/100 can be replaced by scaffold tubes and standard couplers.



Fit the ties from the auxiliary decks at height increments of 8 m, see Section "A4 Anchoring" on page 40.

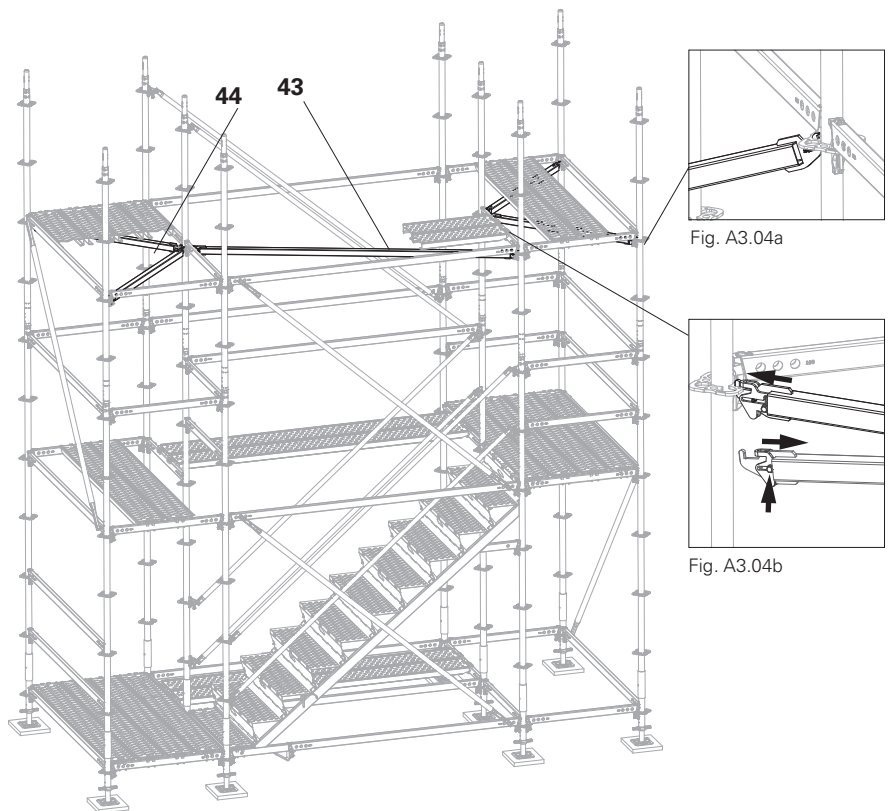

Fig. A3.04

## Remove assembly aids.



### Warning

During disassembly, there is no lateral protection on the scaffold!  
A fall can result in serious injuries or even death.

⇒ Use personal protective equipment to prevent falling from a height.

### Dismantling

1. Remove the horizontal ledgers (**3a + 4a + 5a**).
2. Remove the Steel Decks UDG (**32a**) from the level below. (Fig. A3.05)

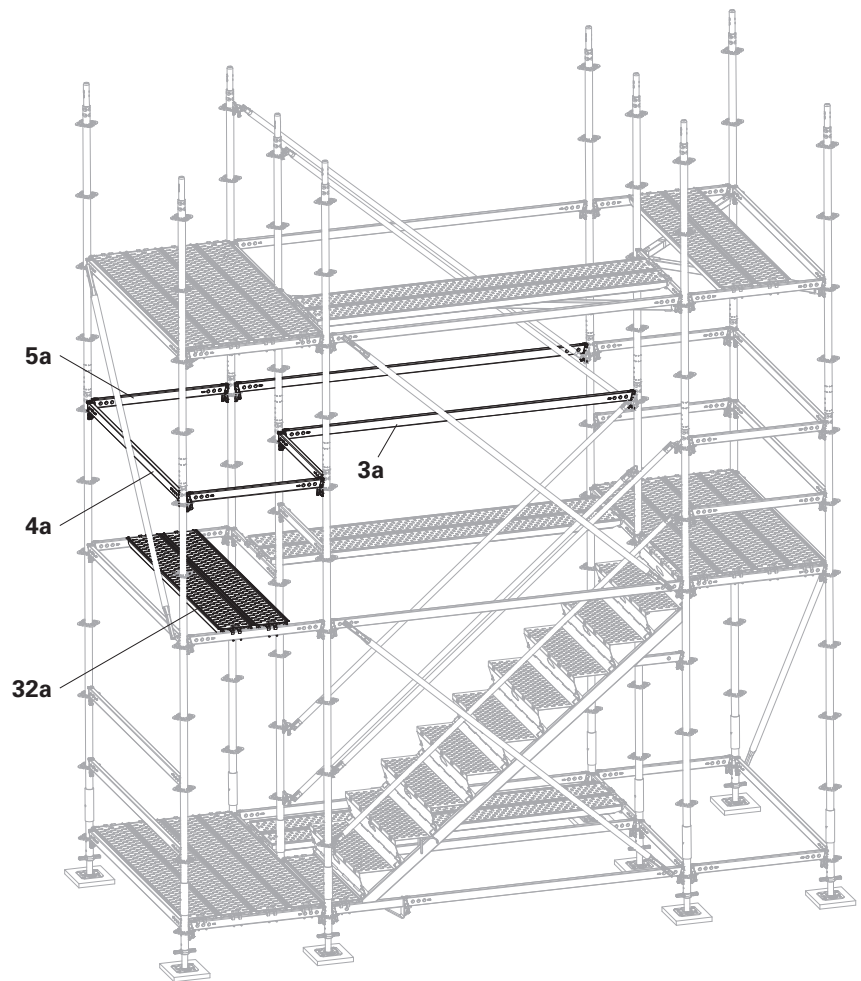

Fig. A3.05

## Stair stringers

<b>4</b> Horizontal Ledger UH-2 200	2x
<b>11</b> Stair Stringer UA 250/200	2x

### Assembly

1. Fit the Stair Stringers UA (**11**) into the rosettes at the top and bottom and hammer in securely.
2. Brace with two Horizontal Ledgers UH-2 200 (**4**). (Fig. A3.06).

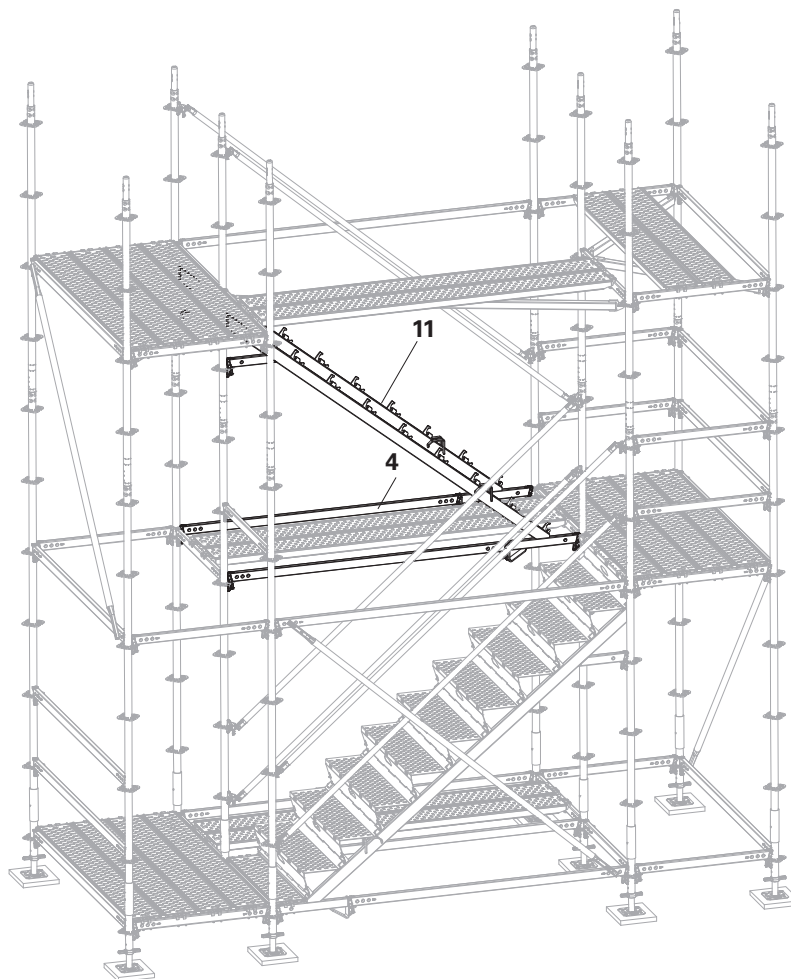

Fig. A3.06

## Ledger braces

<b>5</b> Horizontal Ledger UH-2 100	1x
<b>45</b> Ledger Brace UBL-2 250/200	2x

### Assembly

1. Fit Ledger Braces UBL-2 250/200 (**45**) at two levels on the long side. Insert the tilt finger into the upper horizontal ledger.
2. Fit Horizontal Ledger UH-2 100 (**5**).
3. Remove Steel Decks UDG-2 (**34a**) from the level below.  
(Fig. A3.07)



Are all tilt gravity pins (**45.1**) of the Ledger Braces UBL in a transverse position and resting on both sides of the hole? (Fig. A3.07a)

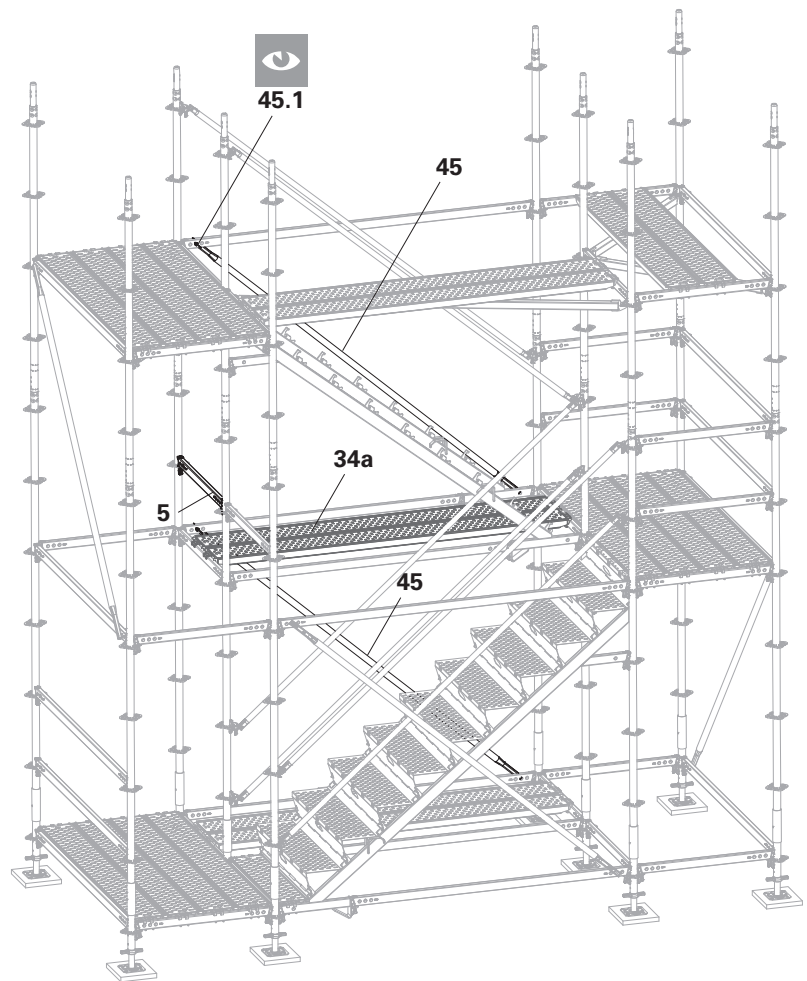

Fig. A3.07

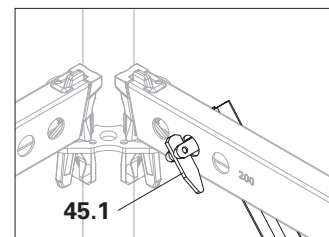

Fig. A3.07a

## Steps

<b>12</b> Step UAR 100	9x
<b>13</b> End Step UAE 100	1x
<b>31</b> Steel Deck UDG-2 25x100	1x

### Assembly

The steps as installed as described in Section "Steps" on page 22 ff .



- Are all steps connected and secured?
- Is the end step clipped into the horizontal ledger?
- Is the end step's lift lock working?

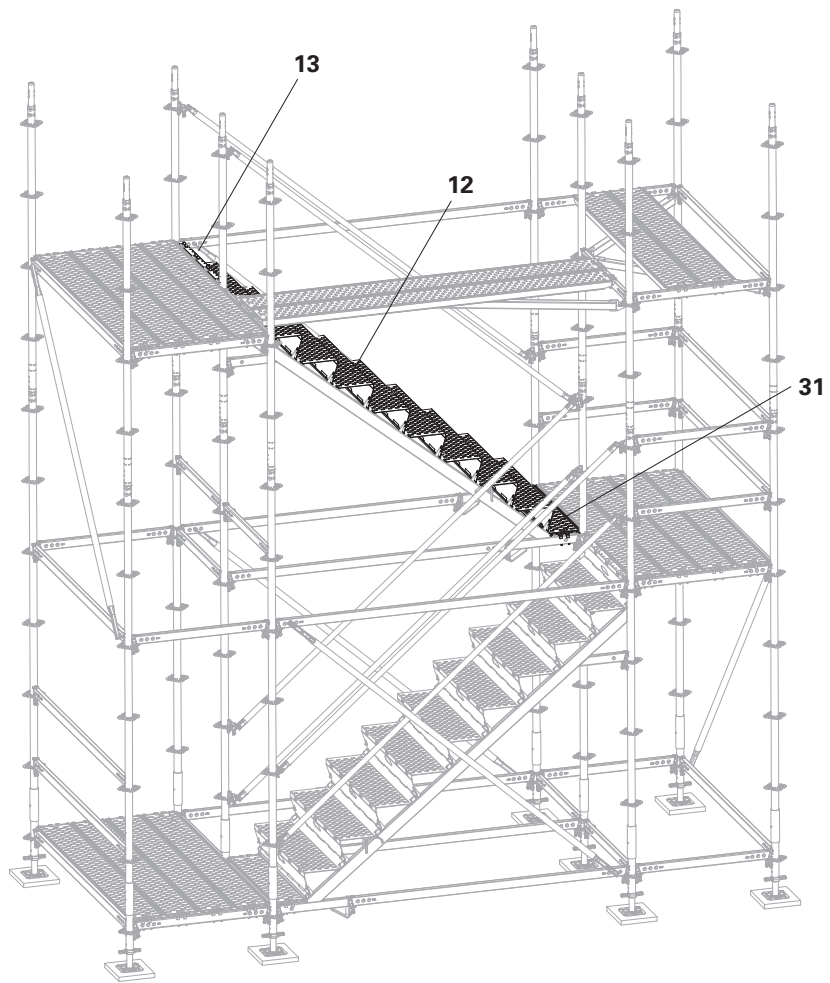

Fig. A3.08

## Guardrail

### Components

<b>4</b>	Horizontal Ledger UH-2 200	2x
<b>5</b>	Horizontal Ledger UH-2 100	4x
<b>41</b>	Node Brace UBK 250/200	2x

### Assembly aid components

<b>3a</b>	Horizontal Ledger UH-2 250	2x
<b>4a</b>	Horizontal Ledger UH-2 200	1x
<b>5a</b>	Horizontal Ledger UH-2 100	3x

### Assembly

1. Fit Node Braces UBK (**41**) into the rosettes.
  2. Fit Horizontal Ledgers UH-2 (**4 + 5**) as a landing guardrail. (Fig. A3.089)
  3. Fit the Horizontal Ledgers UH-2 (**3a + 4a + 5a**) as assembly guardrails.
  4. Hammer down the wedges of all the ledgers.
- The second flight of stairs is now installed.

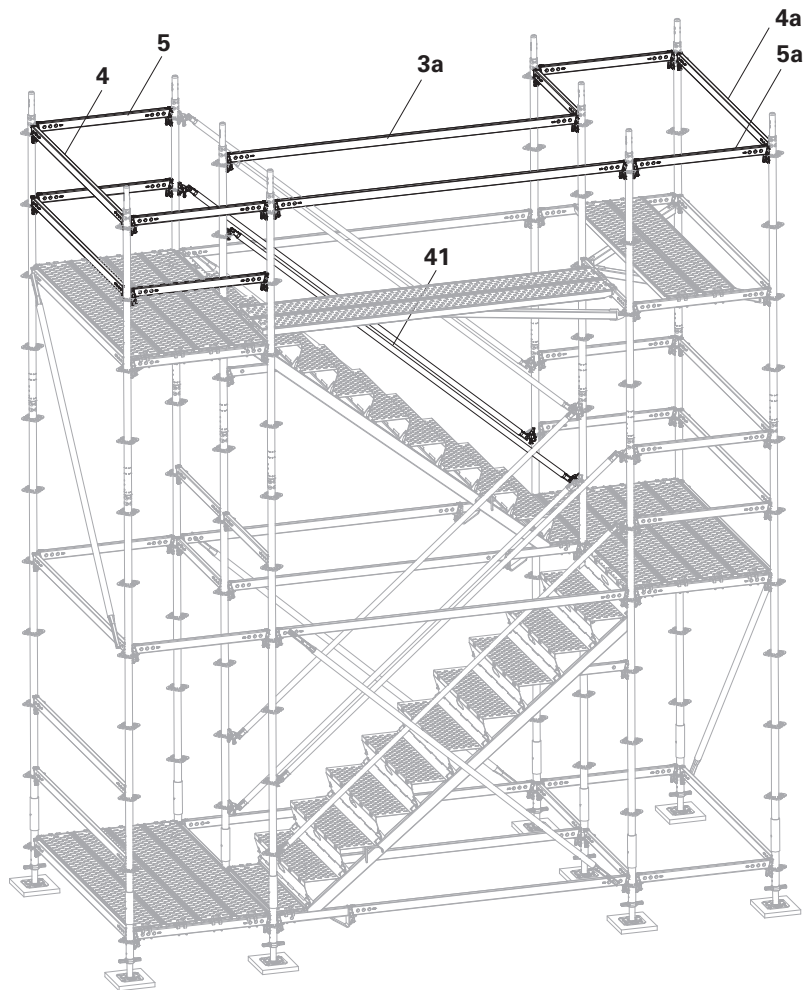

Fig. A3.09

## Additional flights of stairs

Fig. A3.10 shows the view from the building side.

Install additional flights of stairs as described in Section "A3 Additional staircases" on page 28 ff.

### Staircase assembly is to take place in line with the erection progress:

1. Assembly aids from one flight of stairs to the next.
2. Horizontal Braces UBH (43, 44) every 4.0 m. (Fig. A3.10)
3. Anchoring every 8.0 m.  
The last level must always be anchored.
4. Insert locking pins  $\varnothing 48$  into the standards in the last 8 m.

### Last flight of stairs

<b>3</b>	Horizontal Ledger UH-2 250	2x
----------	----------------------------	----

### Assembly

Brace with Horizontal Ledger UH-2 250 **(3)** (instead of Horizontal Ledger UH-2 200 and the Stair Stringers UA). (Fig. A3.10)

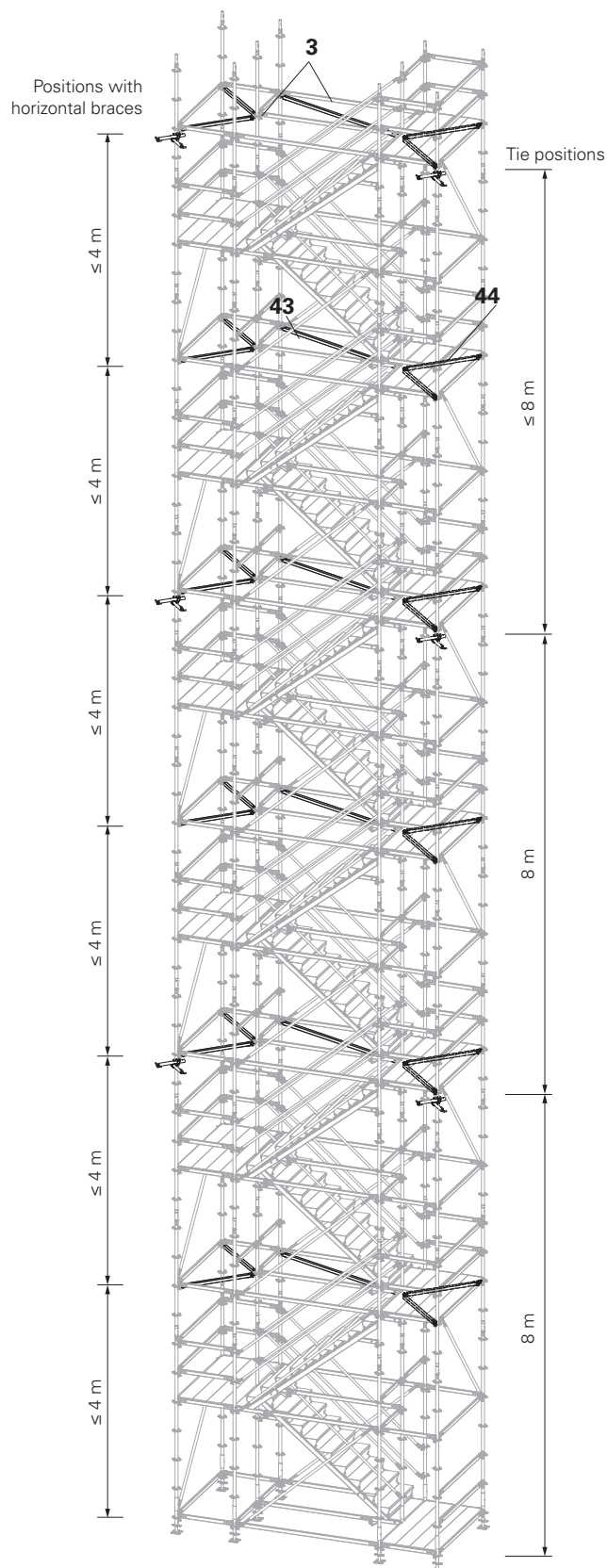

Fig. A3.10

## Access into the building

Fig. A3.11 shows the platform heights when the base height is 30 cm. A footbridge into the building can be established at each landing platform. View from the side of the building.

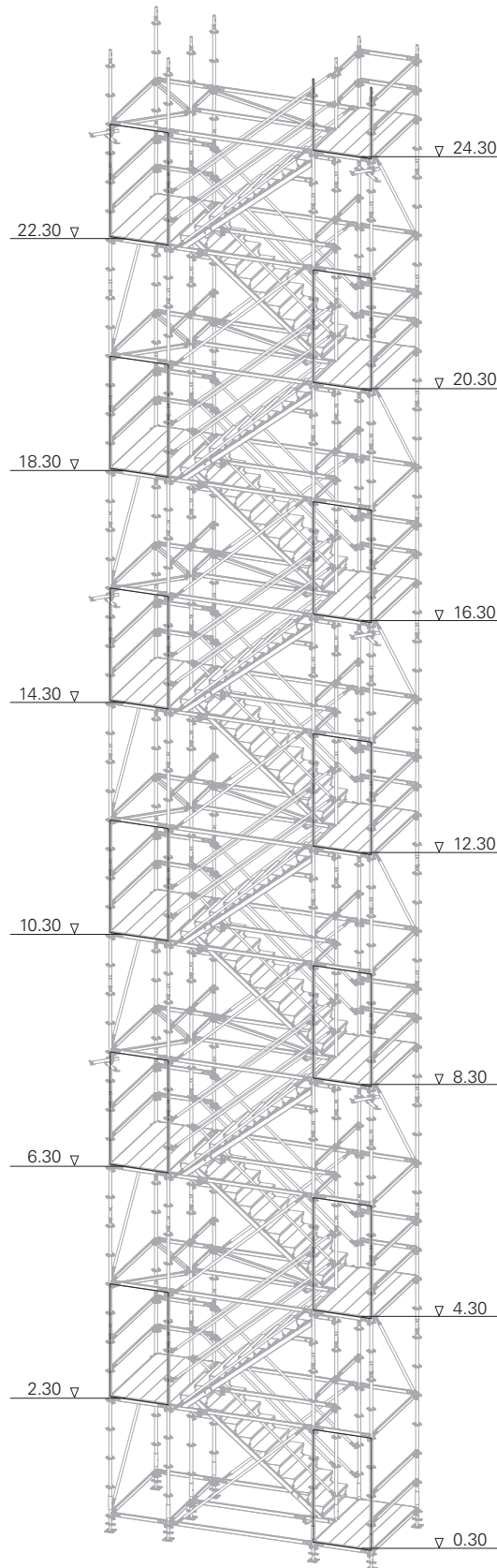

Fig. A3.11

### Footbridge

It is possible to access the building from all landing platforms. To form the footbridge, assemble PERI UP Flex components according to the site-specific requirements.

Remove the Horizontal Ledgers UH-2 100 from the inner side of the tower. Static replacement measures are not necessary. (Fig. A3.12)



Before the horizontal ledgers serving as lateral protection are removed, a safe footbridge into the building must be formed in full.

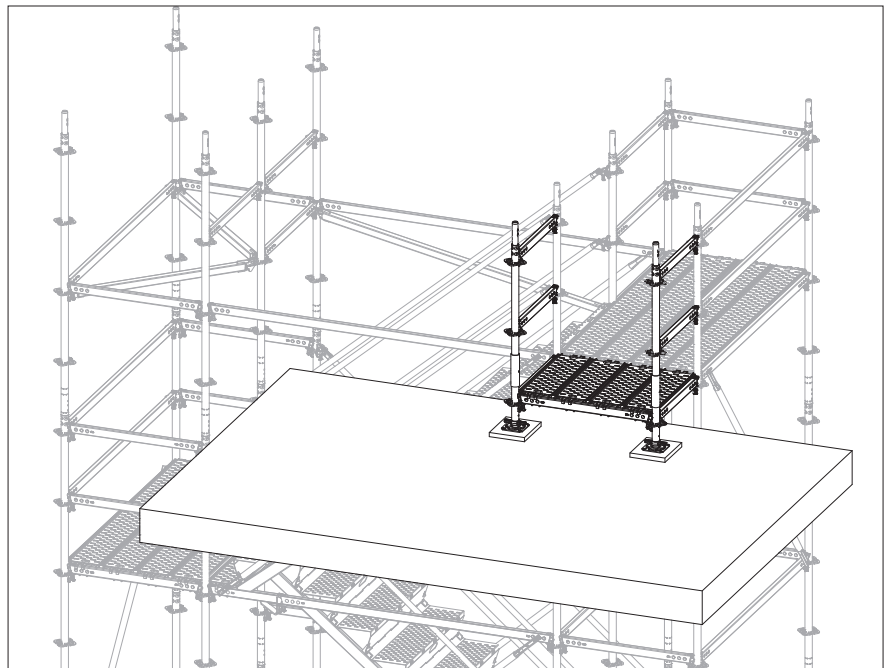
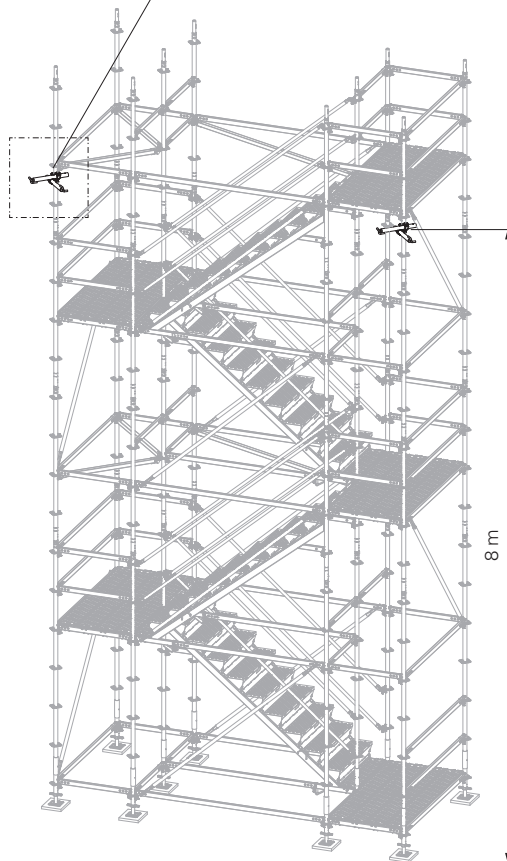
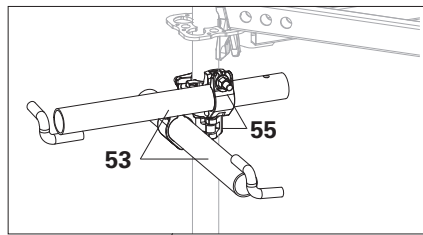

Fig. A3.12



- Ties do not transfer vertical loads!
- Ties should be installed progressively with the erection of the scaffolding.
  - Fix ties with M12 eyebolts or an equivalent connection.
  - The load-bearing capacity of the fixing materials between the wall ties and anchoring base must be verified by the contractor. Tie loads: see tables in Part B.
  - Insert the first tie at a height of 8.0 m. The positions of the other ties are shown in the Tables in Part B.
  - Install ties only in the levels that have been braced with horizontal braces.



## Triangulated tie

For shorter wall spacings, both corner standards must be connected with triangulated ties under 45°.

<b>53</b> Wall Tie UWT 45	4x
<b>55</b> Standard Coupler NK 48/48	4x

### Assembly

1. Fix the standard couplers (**55**) to the corner standards with Wall Ties UWT 45 (**53**).
2. Fix Wall Ties UWT 45 to the wall, e.g. with M12 eyebolts and dowels, or equivalent connection.

Fig. A4.01

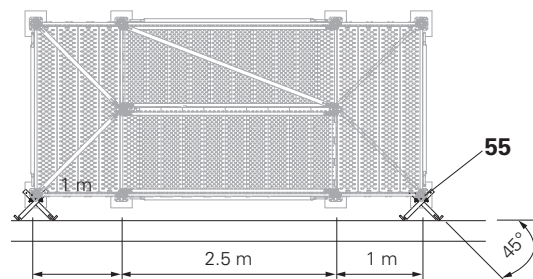

Fig. A4.02

## Single wall ties with bracing

For large wall spacings up to max. 200 cm, single wall ties with crossed diagonals are to be used.

<b>54</b>	Wall Tie UWT from 140 onwards	2x
<b>57</b>	Scaffold Tube 48.3 x 3.2	2x
<b>55</b>	Standard Coupler NK 48/48	2x
<b>56</b>	Swivel Coupling DK 48/48	5x

### Assembly

1. Fix wall ties, e.g. UWT 140 (**54**), to the corner standards using standard couplers (**55**).
2. Fix Wall Ties UWT 140 to the wall, e.g. with M12 eyebolts and dowels, or equivalent connection.
3. Fix scaffold tubes (**57**) to the Wall Ties UWT 140 using swivel couplings (**56**). (Fig. A4.05)
4. At the intersection point of the scaffold tubes, fit swivel couplers for connecting both scaffold tubes. (Fig. A4.03 and A4.04)

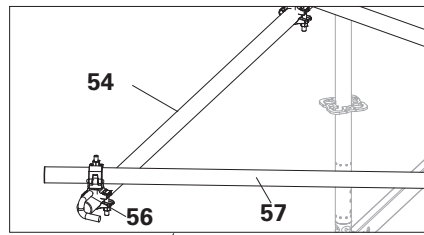

Fig. A4.05

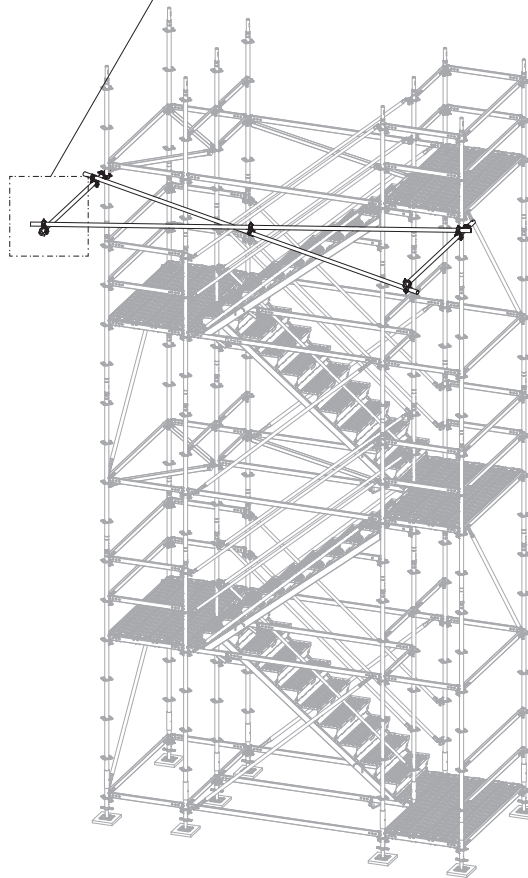

Fig. A4.03

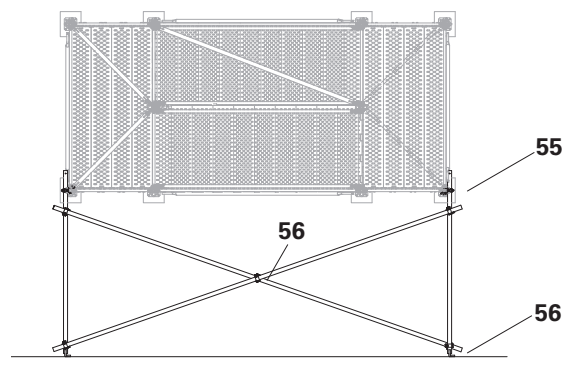

Fig. A4.04

## Sequence

- Dismantle from top to bottom, i.e. in the reverse order as shown in the assembly procedure.
- Install auxiliary decks and guardrails in the opposite order to the one described in the assembly process. Dismantle stair parts and remove auxiliary decks and guardrails.
- Remove the ties progressively along with the stair tower from top to bottom.
- In the event of work being interrupted, the top level should not extend more than 3.0 m beyond the last tie position.



The scaffolding contractor can also undertake other measures on the basis of his own risk assessment.

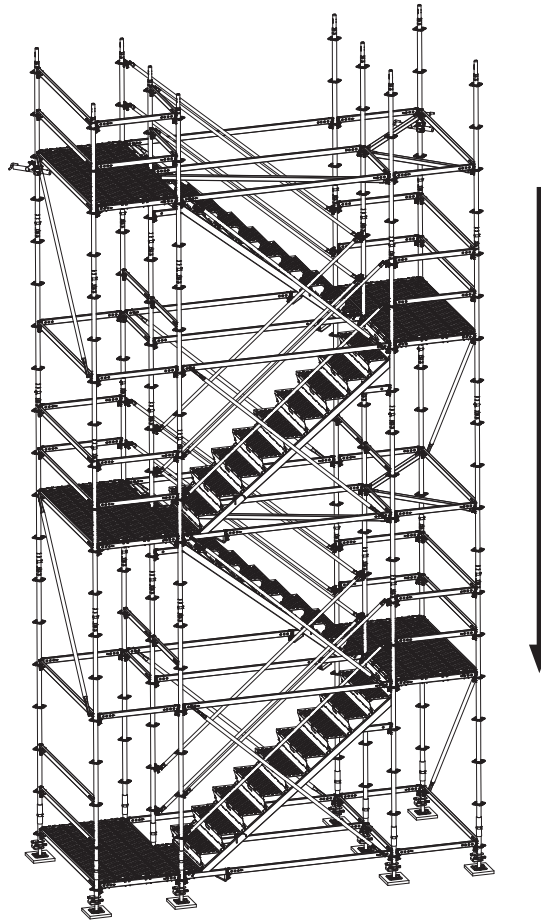

Fig. A5.01

## Step width 125 cm

In Sections A1 to A5, the assembly process for a staircase with a step width of 100 cm is shown. For the larger step width of 125 cm, the information applies analogously. There are changes to the ground plan dimensions of the staircase and therefore also the lengths of the following components:

- Step UAR 125
- End Step UAE 125
- Steel Deck UDG-2 25x125
- Steel Deck UDG-2 25x250
- Horizontal Ledger UH-2 125
- Horizontal Ledger UH-2 250
- Ledger Brace UBL 250/200
- Horizontal Brace UBH Flex 125/125
- Horizontal Brace UBH Flex 125/250

Other components are not affected.  
Landing platform variant: see Section A2.

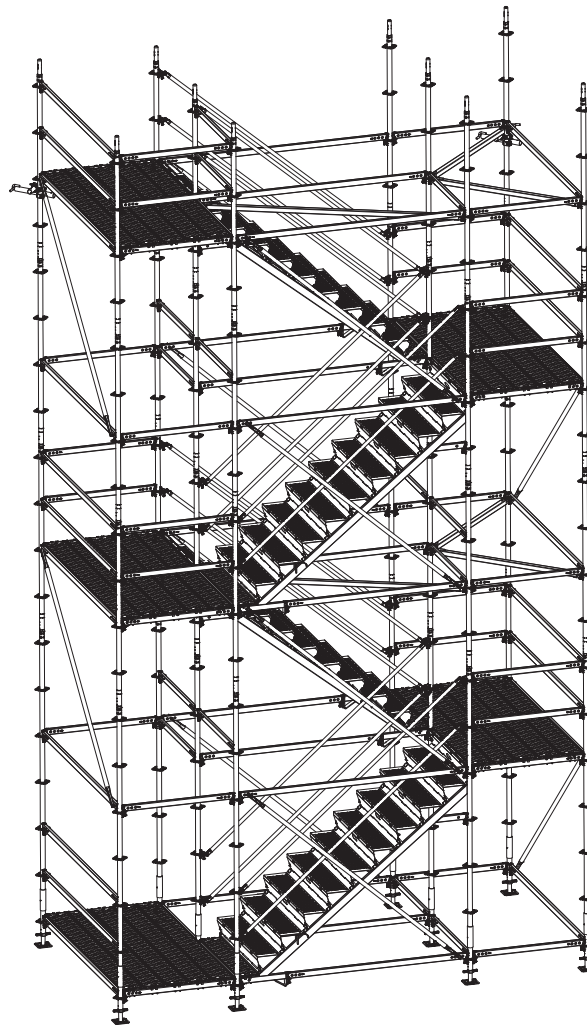

Fig. A6.01

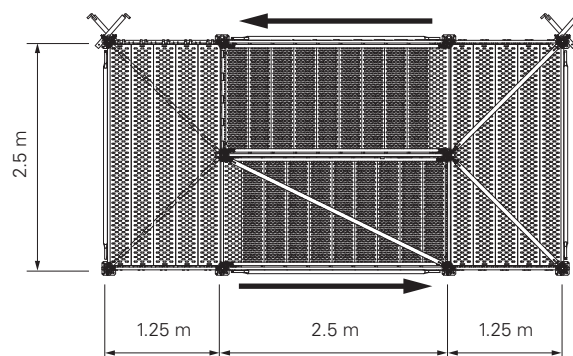

Fig. A6.02

## Loads on Steps UAR

The permissible live load is

- Single load in the centre of the bay:  
 $P = 2.4 \text{ kN}$
- Surface load:  
 $p = 3.0 \text{ kN/m}^2$

## Loads on flights of stairs and landing platforms

The permissible live load is:  
 $p = 3.0 \text{ kN/m}^2$

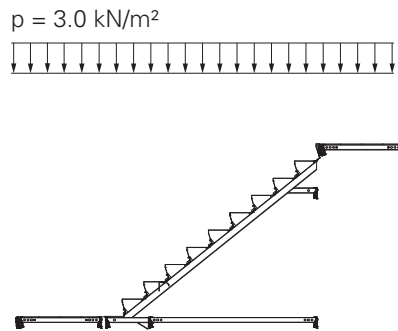

## Loads on stair tower

A stair tower consists of several flights of stairs and landing platforms, which are arranged above one another like a tower.

The permissible live load of the stair tower is 40.0 kN, evenly distributed across all standards (according to NF P 93-522) corresponds to:

- $p = 2.00 \text{ kN/m}^2$  for no more than 20 linear metres (H1) in the case of a Staircase 100.  
For staircases with a landing platform width of 1.0 m, approx. 4 levels are loaded.
- $p = 2.00 \text{ kN/m}^2$  for no more than 16 linear metres (H2) in the case of a Staircase 125.  
For staircases with a landing platform width of 1.25 m, approx. 3 levels are loaded.

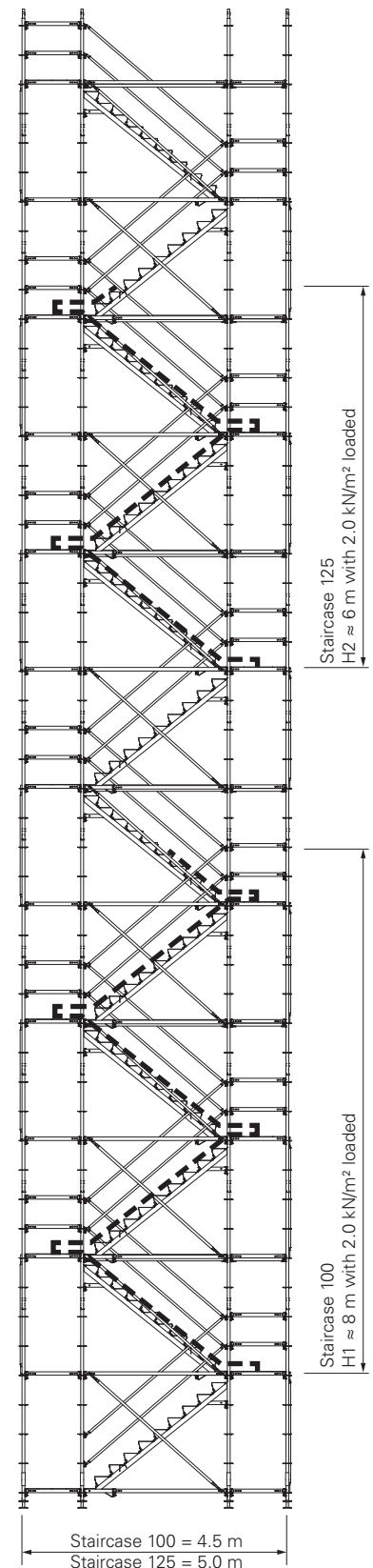
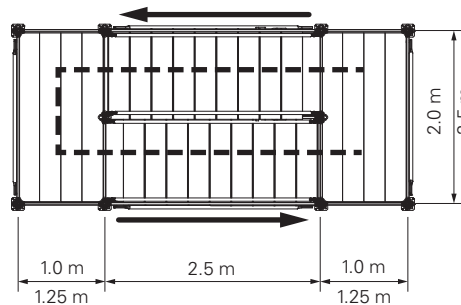



## Step width 100 cm

The support forces for the stair towers are given in the table and depend on the respective overall height.

**Table 1**

Height of access point [m]	Foundation for complete tower			Foundation for individual standards			Stair tower with step width 100 cm
	medium standard loads [kN]			max. standard loads [kN]			
	A	B	C	A	B	C	
4.3	2.7	3.1	3.5	4.0	4.4	4.8	
6.3	4.0	4.7	5.2	5.9	6.6	7.1	
8.3	5.3	6.2	6.9	7.9	8.8	9.5	
10.3	5.6	6.7	7.6	8.2	9.3	10.2	
12.3	5.9	7.3	8.3	8.5	9.9	10.9	
14.3	6.2	7.8	9.0	8.8	10.4	11.6	
16.3	6.5	8.3	9.7	9.1	10.9	12.3	
18.3	6.8	8.9	10.4	9.4	11.5	13.0	
20.3	7.1	9.4	11.1	9.7	12.0	13.7	
22.3	7.4	9.9	11.8	10.0	12.5	14.4	
24.3	7.7	10.5	12.5	10.3	13.1	15.1	
26.3	8.0	11.0	13.2	10.6	13.6	15.8	
28.3	8.3	11.5	13.9	10.9	14.1	16.5	
30.3	8.6	12.1	14.6	11.2	14.7	17.2	
32.3	8.9	12.6	15.3	11.5	15.2	17.9	
34.3	9.2	13.1	16.0	11.8	15.7	18.6	
36.3	9.6	13.7	16.7	12.2	16.3	19.3	
38.3	9.9	14.2	17.4	12.5	16.8	20.0	
40.3	10.2	14.7	18.1	12.8	17.3	20.7	
42.3	10.5	15.3	18.9	13.1	17.9	21.5	
44.3	10.8	15.8	19.6	13.4	18.4	22.2	
46.3	11.1	16.3	20.3	13.7	18.9	22.9	
48.3	11.4	16.9	21.0	14.0	19.5	23.6	
50.3	11.7	17.4	21.7	14.3	20.0	24.3	

For the medium standard loads, the permissible load was distributed evenly across all standards. To determine the maximum leg loads, 80 % of the permissible load was concentrated on one side of the scaffolding.

## Step width 125 cm

The support forces for the stair towers are given in the table and depend on the respective overall height.

Table 2

Height of access point [m]	Foundation for complete tower			Foundation for individual standards			Stair tower with step width 125 cm
	medium standard loads [kN]			max. standard loads [kN]			
	A	B	C	A	B	C	
2.3	1.4	1.6	1.9	2.0	2.3	2.5	
4.3	2.7	3.2	3.7	4.0	4.5	5.0	
6.3	4.0	4.8	5.5	6.0	6.8	7.4	
8.3	5.4	6.4	7.3	8.0	9.0	9.9	
10.3	5.7	7.0	8.0	8.3	9.6	10.6	
12.3	6.0	7.6	8.8	8.6	10.2	11.4	
14.3	6.3	8.1	9.6	8.9	10.7	12.2	
16.3	6.7	8.7	10.4	9.3	11.3	13.0	
18.3	7.0	9.3	11.2	9.6	11.9	13.8	
20.3	7.3	9.9	12.0	9.9	12.5	14.6	
22.3	7.7	10.5	12.8	10.3	13.1	15.4	
24.3	8.0	11.1	13.6	10.6	13.7	16.2	
26.3	8.3	11.6	14.4	10.9	14.2	17.0	
28.3	8.6	12.2	15.2	11.2	14.8	17.8	
30.3	9.0	12.8	16.0	11.6	15.4	18.6	
32.3	9.3	13.4	16.8	11.9	16.0	19.4	
34.3	9.6	14.0	17.6	12.2	16.6	20.2	
36.3	9.9	14.6	18.4	12.5	17.2	21.0	
38.3	10.3	15.1	19.2	12.9	17.7	21.8	
40.3	10.6	15.7	20.0	13.2	18.3	22.6	

For the medium standard loads, the permissible load was distributed evenly across all standards. To determine the maximum leg loads, 80 % of the permissible load was concentrated on one side of the scaffolding.

## Tie positions – installation heights

**Table 3**

Staircase 100

Height of access point [m]	Tie positions	Tie installation height [m]						
		8	16	24	32	40	48	50
2 – 8	1	8						
10 – 16	2	8	16					
18 – 24	3	8	16	24				
26 – 32	4	8	16	24	32			
34 – 40	5	8	16	24	32	40		
42 – 48	6	8	16	24	32	40	48	
50	7	8	16	24	32	40	48	50

Staircase 125

Height of access point [m]	Tie positions	Tie installation height [m]						
		8	16	24	32	40		
2 – 8	1	8						
10 – 16	2	8	16					
18 – 24	3	8	16	24				
26 – 32	4	8	16	24	32			
34 – 40	5	8	16	24	32	40		

### Staircase 100:

#### Tension and compression-proof anchorage

Tie heights are measured without the length of the jack extension.

#### Height up to 50 m:

Fit the first tie at a height of 8.0 m, and then at spacings of 8.0 m.

#### Top level:

Always anchor!

#### Intermediate access on every storey:

Remove Horizontal Ledger UH-2 100 on the inner side of the landing platform.

### Staircase 125:

#### Tension and compression-proof anchorage

Tie heights are measured without the length of the jack extension.

#### Height up to 40 m:

Fit the first tie at a height of 8.0 m, and then at spacings of 8.0 m.

#### Top level:

Always anchor!

#### Intermediate access on every storey:

Remove Horizontal Ledger UH-2 125 on the inner side of the landing platform.

## Anchor forces

The tie forces have been calculated for an unclad stair tower in front of an open facade (60 % openings).

A wind load with the following dynamic pressures has been taken into account for the face areas of the scaffold:

### Load combination – service condition

Constant dynamic pressure:  
 $q = 0.20 \text{ kN/m}^2$

### Load combination – max. wind load

Dynamic pressure changing with height:  
 $q_1 = 0.60 \text{ kN/m}^2$  (at 0 m)  
 $q_2 = 0.77 \text{ kN/m}^2$  (at 24 m) and  
 $q_3 = 0.87 \text{ kN/m}^2$  (at 50 m)  
 with a service life factor of 0.7.

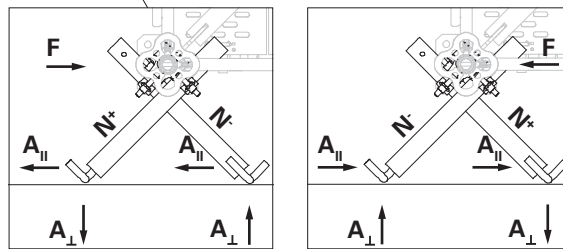
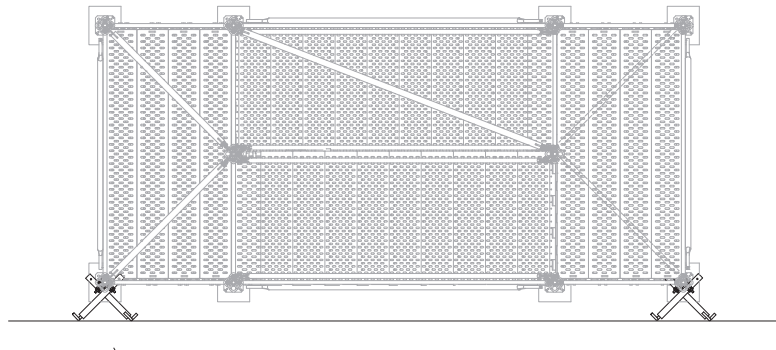

### Tie loads for Staircase 100

- at 8 m tie spacing:  
 max.  $N = 5.7 \text{ kN}$   
 max.  $A_{II} = \text{max. } A_{\perp} = 4.0 \text{ kN}$
- at 6 m tie spacing:  
 max.  $N = 4.3 \text{ kN}$   
 max.  $A_{II} = \text{max. } A_{\perp} = 3.0 \text{ kN}$
- at 4 m tie spacing:  
 max.  $N = 3.2 \text{ kN}$   
 max.  $A_{II} = \text{max. } A_{\perp} = 2.3 \text{ kN}$

### Tie loads for Staircase 125

- at 8 m tie spacing:  
 max.  $N = 7.5 \text{ kN}$   
 max.  $A_{II} = \text{max. } A_{\perp} = 5.5 \text{ kN}$
- at 6 m tie spacing:  
 max.  $N = 5.7 \text{ kN}$   
 max.  $A_{II} = \text{max. } A_{\perp} = 4.1 \text{ kN}$
- at 4 m tie spacing:  
 max.  $N = 4.2 \text{ kN}$   
 max.  $A_{II} = \text{max. } A_{\perp} = 3.2 \text{ kN}$

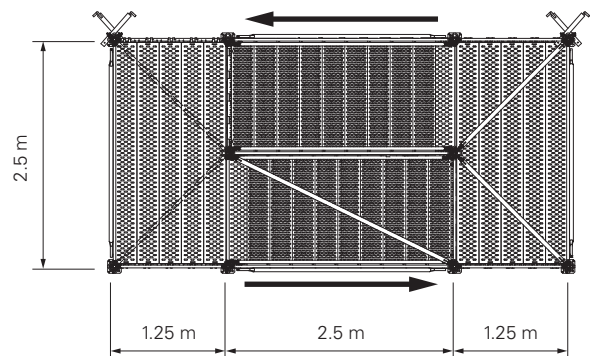
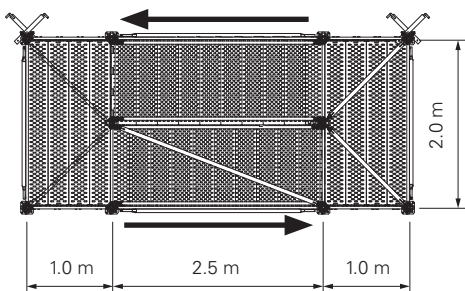

# PERI UP Flex Staircase 100, 125



Article no.	Weight kg
100411	3.390

## Base Spindle UJB 38-50/30

### Note

With captive red quick jack nut.

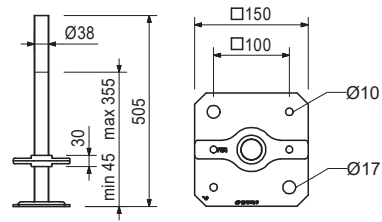

### Accessories

100863	1.020
--------	-------

## Spindle Locking UJS

100863	1.020
--------	-------

## Spindle Locking UJS

Locks base spindles and section spindles  
Ø 38 mm in the leg during moving procedures.

### Technical data

Permissible load 1.5 kN.

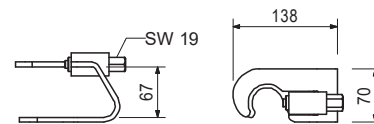

400014	2.470
--------	-------

## Base Standard UVB 24

For fitting directly onto the base spindles.

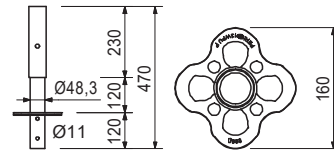

133499	2.270
--------	-------

## Base Standard UVB 25

For fitting directly onto the base spindles.  
Can also be used as 25 cm standard.

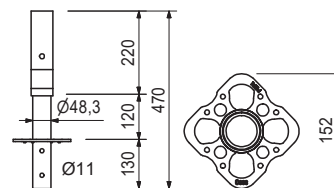

# PERI UP Flex Staircase 100, 125



Article no. Weight kg

417194 3.980

## Base Standard UVB 49

For fitting directly onto the base spindles. Reduces necessary spindle extensions with 25 cm rosette spacing.

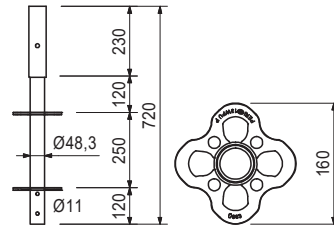

135187

3.590

## Base Standard UVB 50

For fitting directly onto the base spindles. Can also be used as 50 cm standard.

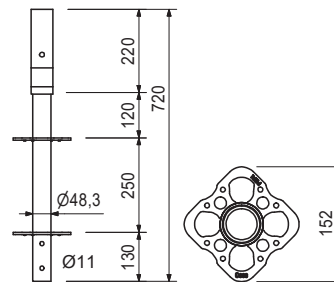

# PERI UP Flex Staircase 100, 125



Article no. Weight kg

Article no.	Weight kg	Standards UVR	L
402859	3.080	<b>Standard UVR 50</b>	500
401306	5.380	<b>Standard UVR 100</b>	1 000
402860	7.690	<b>Standard UVR 150</b>	1 500
400009	10.000	<b>Standard UVR 200</b>	2 000
400012	14.700	<b>Standard UVR 300</b>	3 000
400013	19.200	<b>Standard UVR 400</b>	4 000

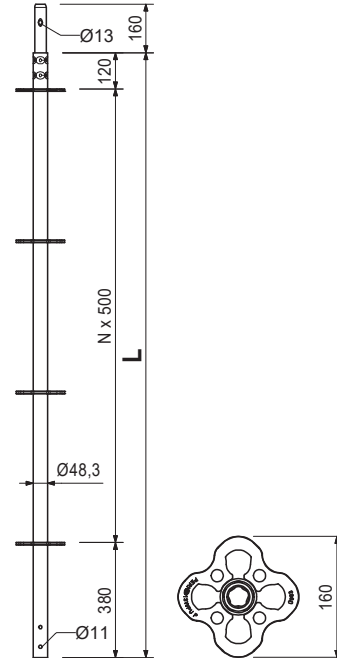

Article no.	Weight kg	Standards UVR-2	L
132219	2.490	<b>Standard UVR-2 50</b>	500
132224	4.350	<b>Standard UVR-2 100</b>	1 000
132229	6.190	<b>Standard UVR-2 150</b>	1 500
132234	8.040	<b>Standard UVR-2 200</b>	2 000
132239	11.700	<b>Standard UVR-2 300</b>	3 000

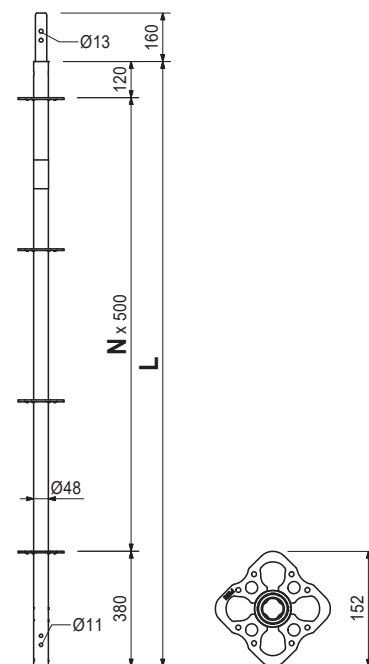

# PERI UP Flex Staircase 100, 125

Article no. Weight kg

Article no.	Weight kg	Top Standards UVH	L
401309	2.510	<b>Top Standard UVH 50</b>	500
400000	4.610	<b>Top Standard UVH 100</b>	1 000
400003	6.920	<b>Top Standard UVH 150</b>	1 500
400005	9.240	<b>Top Standard UVH 200</b>	2 000
400007	11.500	<b>Top Standard UVH 250</b>	2 500

Without pin for mounting head spindles.

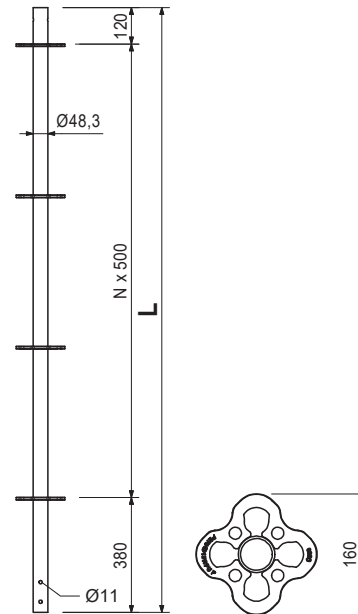

Article no.	Weight kg	Top Standards UVH-2	L
132123	2.100	<b>Top Standard UVH-2 50</b>	500
132194	4.210	<b>Top Standard UVH-2 100</b>	1 000
132198	6.310	<b>Top Standard UVH-2 150</b>	1 500
132200	8.420	<b>Top Standard UVH-2 200</b>	2 000
132202	10.500	<b>Top Standard UVH-2 250</b>	2 500

Without pin for mounting head spindles.

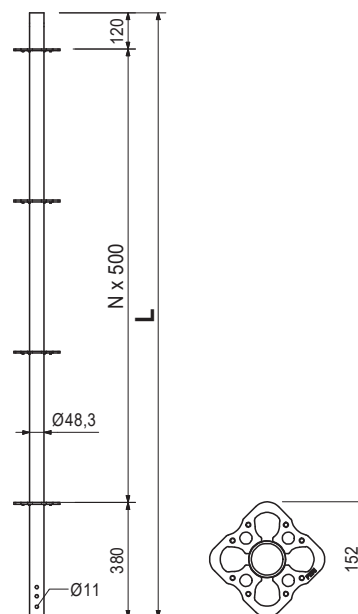

# PERI UP Flex Staircase 100, 125



Article no. Weight kg

417195 7.600

## Top Standard UVH 125

Without pin for mounting head spindles. Reduces necessary spindle extensions with 25 cm rosette spacing.

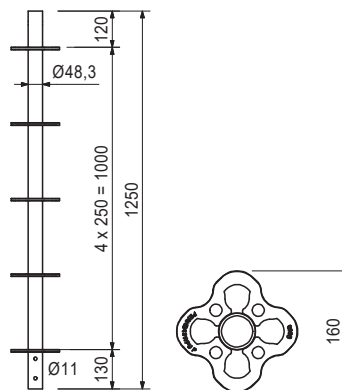

132196

6.060

## Top Standard UVH-2 125

Without pin for mounting head spindles.

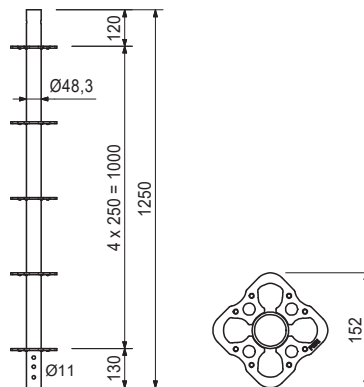

# PERI UP Flex Staircase 100, 125



Article no. Weight kg

Article no.	Weight kg	
414613	1.420	<b>Horizontal Ledger UH Plus</b>
414595	2.070	<b>Horizontal Ledger UH 25 Plus</b>
429982	2.520	<b>Horizontal Ledger UH 50 Plus</b>
414629	2.730	<b>Horizontal Ledger UH 67 Plus</b>
414632	4.390	<b>Horizontal Ledger UH 75 Plus</b>
414638	5.340	<b>Horizontal Ledger UH 100 Plus</b>
414641	4.720	<b>Horizontal Ledger UH 125 Plus</b>
417032	5.380	<b>Horizontal Ledger UH 175 Plus</b>
414645	6.040	<b>Horizontal Ledger UH 200 Plus</b>
416356	6.700	<b>Horizontal Ledger UH 225 Plus</b>
414648	7.360	<b>Horizontal Ledger UH 250 Plus</b>
414651	8.680	<b>Horizontal Ledger UH 300 Plus</b>

L	X
204	250
454	500
624	670
704	750
954	1000
1204	1250
1454	1500
1704	1750
1954	2000
2204	2250
2454	2500
2954	3000

### Note

With length marking for easier identification.

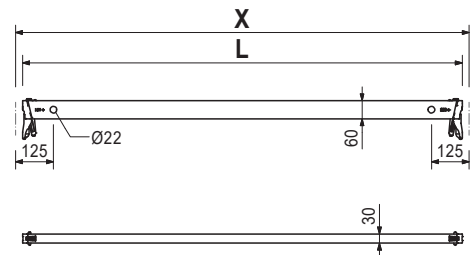
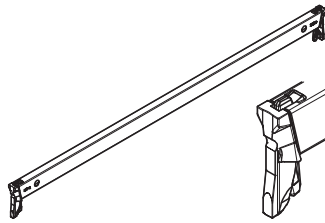

Article no.	Weight kg	
131995	1.410	<b>Horizontal Ledger UH-2</b>
133900	1.590	<b>Horizontal Ledger UH-2 25</b>
131998	2.030	<b>Horizontal Ledger UH-2 33</b>
133903	2.480	<b>Horizontal Ledger UH-2 50</b>
132213	2.690	<b>Horizontal Ledger UH-2 67</b>
132004	3.740	<b>Horizontal Ledger UH-2 100</b>
132007	4.510	<b>Horizontal Ledger UH-2 125</b>
132010	4.680	<b>Horizontal Ledger UH-2 150</b>
132013	5.340	<b>Horizontal Ledger UH-2 175</b>
132016	6.000	<b>Horizontal Ledger UH-2 200</b>
132019	6.660	<b>Horizontal Ledger UH-2 225</b>
132025	7.320	<b>Horizontal Ledger UH-2 250</b>
132022	8.650	<b>Horizontal Ledger UH-2 300</b>

L	X
204	250
284	330
454	500
624	670
704	750
954	1000
1204	1250
1454	1500
1704	1750
1954	2000
2204	2250
2454	2500
2954	3000

### Note

With length marking for easier identification.

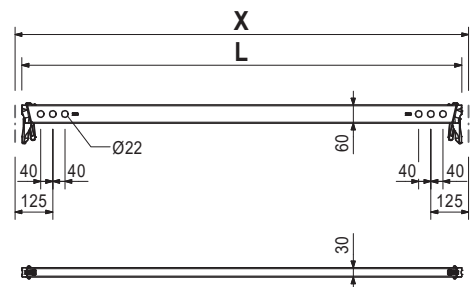
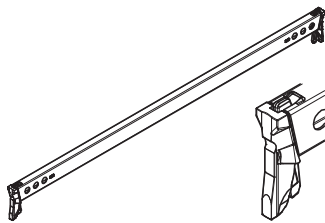

# PERI UP Flex Staircase 100, 125



Article no. Weight kg

Article no.	Weight kg		L	X
414681	10.900	<b>Horizontal Ledger UHV Plus</b>	1454	1500
414687	14.700	<b>Horizontal Ledger UHV 150 Plus</b>	1954	2000
414691	17.900	<b>Horizontal Ledger UHV 200 Plus</b>	2454	2500
414695	21.600	<b>Horizontal Ledger UHV 250 Plus</b>	2954	3000
		<b>Horizontal Ledger UHV 300 Plus</b>		

For high loads, e.g. in the case of material storage.

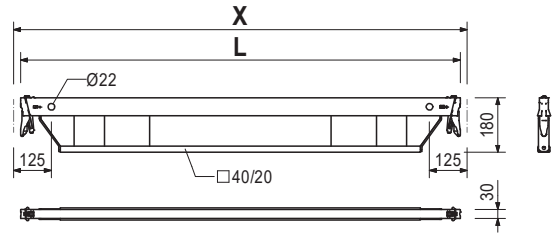
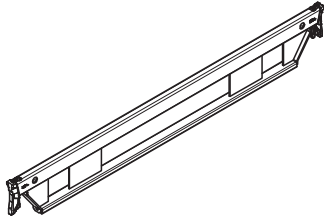

Article no.	Weight kg		L	X
137020	9.410	<b>Horizontal Ledger UHV-2</b>	1454	1500
137025	12.700	<b>Horizontal Ledger UHV-2 150</b>	1954	2000
137030	15.200	<b>Horizontal Ledger UHV-2 200</b>	2454	2500
137035	18.500	<b>Horizontal Ledger UHV-2 250</b>	2954	3000
		<b>Horizontal Ledger UHV-2 300</b>		

For high loads, e.g. in the case of material storage.

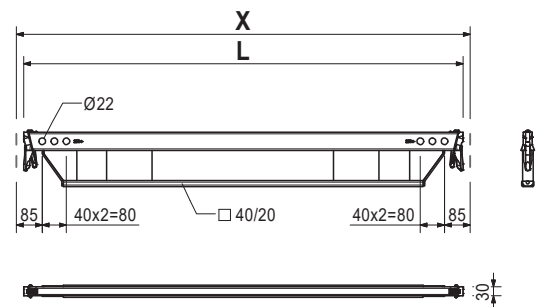
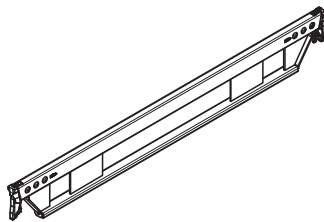

Article no. Weight kg

401731 0.841

## Ledger-to-Ledger Coupler UHA

For connecting horizontal ledgers at right-angles.

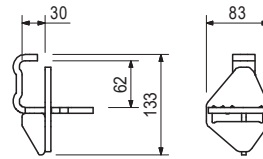

136582 0.829

## Ledger-to-Ledger Coupler UHA-2

For connecting horizontal ledgers at right-angles.

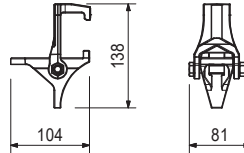
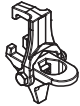

130562 0.623

## Guardrail Holder EPW

For installing the Guardrail Posts EPG to rosettes.

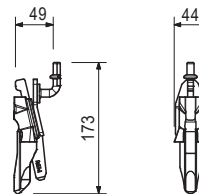

130191	1.150	<b>Guardrail Posts EPG</b>
130193	1.680	<b>Guardrail Post EPG 67</b>
130195	2.480	<b>Guardrail Post EPG 100</b>
130197	3.280	<b>Guardrail Post EPG 150</b>
130199	4.090	<b>Guardrail Post EPG 200</b>
130201	4.890	<b>Guardrail Post EPG 250</b>
		<b>Guardrail Post EPG 300</b>

**Guardrail Posts EPG**  
**Guardrail Post EPG 67**  
**Guardrail Post EPG 100**  
**Guardrail Post EPG 150**  
**Guardrail Post EPG 200**  
**Guardrail Post EPG 250**  
**Guardrail Post EPG 300**

L	X
735	670
1065	1000
1565	1500
2065	2000
2565	2500
3065	3000

### Note

With length marking for easier identification.

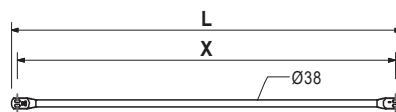
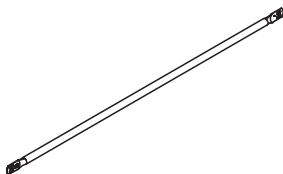

# PERI UP Flex Staircase 100, 125



Article no. Weight kg

Article no.	Weight kg		L	X	Y
		<b>Ledger Braces UBL</b>			
415156	2.660	<b>Ledger Brace UBL 100/50</b>	901	1000	500
415513	4.640	<b>Ledger Brace UBL 100/150</b>	1677	1000	1500
415157	5.810	<b>Ledger Brace UBL 100/200</b>	2136	1000	2000
407867	3.790	<b>Ledger Brace UBL 150/50</b>	1347	1500	500
400055	4.440	<b>Ledger Brace UBL 150/100</b>	1601	1500	1000
402846	5.340	<b>Ledger Brace UBL 150/150</b>	1953	1500	1500
400057	6.380	<b>Ledger Brace UBL 150/200</b>	2358	1500	2000
409034	6.740	<b>Ledger Brace UBL 175/200</b>	2500	1750	2000
404391	5.000	<b>Ledger Brace UBL 200/50</b>	1820	2000	500
400059	5.510	<b>Ledger Brace UBL 200/100</b>	2016	2000	1000
402862	6.240	<b>Ledger Brace UBL 200/150</b>	2305	2000	1500
400061	7.150	<b>Ledger Brace UBL 200/200</b>	2658	2000	2000
430282	5.620	<b>Ledger Brace UBL 225/50</b>	2062	2250	500
430283	6.070	<b>Ledger Brace UBL 225/100</b>	2236	2250	1000
417689	7.580	<b>Ledger Brace UBL 225/200</b>	2829	2250	2000
400063	6.640	<b>Ledger Brace UBL 250/100</b>	2462	2500	1000
402861	7.260	<b>Ledger Brace UBL 250/150</b>	2705	2500	1500
400065	8.050	<b>Ledger Brace UBL 250/200</b>	3010	2500	2000
404762	7.490	<b>Ledger Brace UBL 300/50</b>	2795	3000	500
400067	7.830	<b>Ledger Brace UBL 300/100</b>	2926	3000	1000
404766	8.360	<b>Ledger Brace UBL 300/150</b>	3133	3000	1500
400069	9.040	<b>Ledger Brace UBL 300/200</b>	3400	3000	2000

They are attached using holes in the horizontal ledgers.

**Note**

With length marking for easier identification.

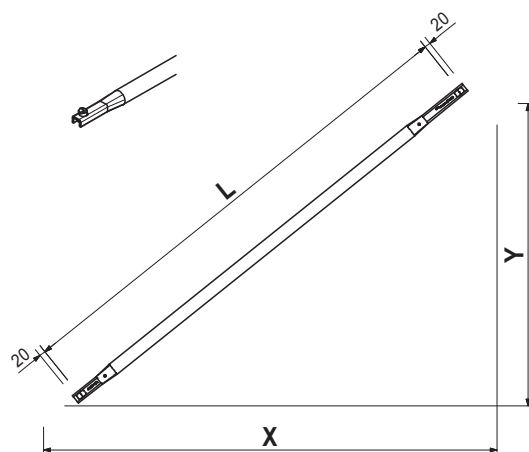
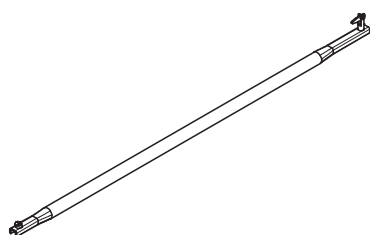

# PERI UP Flex Staircase 100, 125



Article no. Weight kg

Article no.	Weight kg		L	X	Y
		<b>Ledger Braces UBL-2</b>			
132771	2.140	<b>Ledger Brace UBL-2 100/50</b>	901	1000	500
132773	2.830	<b>Ledger Brace UBL-2 100/100</b>	1250	1000	1000
132775	3.680	<b>Ledger Brace UBL-2 100/150</b>	1677	1000	1500
132777	4.600	<b>Ledger Brace UBL-2 100/200</b>	2136	1000	2000
132779	3.030	<b>Ledger Brace UBL-2 150/50</b>	1347	1500	500
132781	3.530	<b>Ledger Brace UBL-2 150/100</b>	1601	1500	1000
132783	4.230	<b>Ledger Brace UBL-2 150/150</b>	1953	1500	1500
132785	5.040	<b>Ledger Brace UBL-2 150/200</b>	2358	1500	2000
132787	5.330	<b>Ledger Brace UBL-2 175/200</b>	2500	1750	2000
132789	3.970	<b>Ledger Brace UBL-2 200/50</b>	1820	2000	500
132791	4.360	<b>Ledger Brace UBL-2 200/100</b>	2016	2000	1000
132793	4.940	<b>Ledger Brace UBL-2 200/150</b>	2305	2000	1500
132795	5.640	<b>Ledger Brace UBL-2 200/200</b>	2658	2000	2000
132797	4.450	<b>Ledger Brace UBL-2 225/50</b>	2062	2250	500
132808	4.800	<b>Ledger Brace UBL-2 225/100</b>	2236	2250	1000
132810	5.980	<b>Ledger Brace UBL-2 225/200</b>	2829	2250	2000
132812	5.250	<b>Ledger Brace UBL-2 250/100</b>	2462	2500	1000
132814	5.730	<b>Ledger Brace UBL-2 250/150</b>	2705	2500	1500
132816	6.340	<b>Ledger Brace UBL-2 250/ 200</b>	3010	2500	2000
132827	5.920	<b>Ledger Brace UBL-2 300/50</b>	2795	3000	500
132829	6.180	<b>Ledger Brace UBL-2 300/100</b>	2926	3000	1000
132831	6.590	<b>Ledger Brace UBL-2 300/150</b>	3133	3000	1500
132833	7.120	<b>Ledger Brace UBL-2 300/200</b>	3400	3000	2000

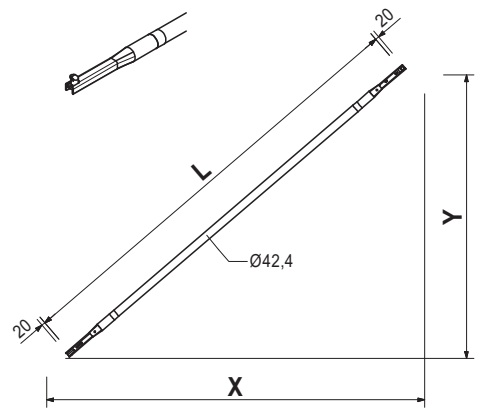
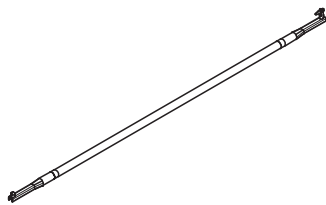

# PERI UP Flex Staircase 100, 125

Article no. Weight kg

Article no.	Weight kg		L	X	Y
		<b>Horizontal Braces UBH Flex</b>			
114818	4.590	<b>Horizontal Brace UBH Flex 100/100</b>	1335	1000	1000
114904	5.630	<b>Horizontal Brace UBH Flex 125/125</b>	1689	1250	1250
114821	5.730	<b>Horizontal Brace UBH Flex 150/100</b>	1725	1500	1000
114908	6.170	<b>Horizontal Brace UBH Flex 150/125</b>	1874	1500	1250
114912	6.660	<b>Horizontal Brace UBH Flex 150/150</b>	2042	1500	1500
114820	7.010	<b>Horizontal Brace UBH Flex 200/100</b>	2161	2000	1000
124097	7.780	<b>Horizontal Brace UBH Flex 200/150</b>	2422	2000	1500
114916	8.740	<b>Horizontal Brace UBH Flex 200/200</b>	2749	2000	2000
114896	8.130	<b>Horizontal Brace UBH Flex 250/75</b>	2541	2500	750
114819	8.360	<b>Horizontal Brace UBH Flex 250/100</b>	2620	2500	1000
114996	8.650	<b>Horizontal Brace UBH Flex 250/125</b>	2720	2500	1250
124101	9.000	<b>Horizontal Brace UBH Flex 250/150</b>	2838	2500	1500
114920	9.840	<b>Horizontal Brace UBH Flex 250/200</b>	3123	2500	2000
114928	10.800	<b>Horizontal Brace UBH Flex 250/250</b>	3456	2500	2500
114900	9.550	<b>Horizontal Brace UBH Flex 300/75</b>	3025	3000	750
114892	9.740	<b>Horizontal Brace UBH Flex 300/100</b>	3092	3000	1000
124105	10.300	<b>Horizontal Brace UBH Flex 300/150</b>	3279	3000	1500
114924	11.000	<b>Horizontal Brace UBH Flex 300/200</b>	3528	3000	2000
114932	11.900	<b>Horizontal Brace UBH Flex 300/250</b>	3826	3000	2500
114936	12.900	<b>Horizontal Brace UBH Flex 300/300</b>	4163	3000	3000

For horizontal bracing of towers.  
Can also be used underneath Decks UDG.

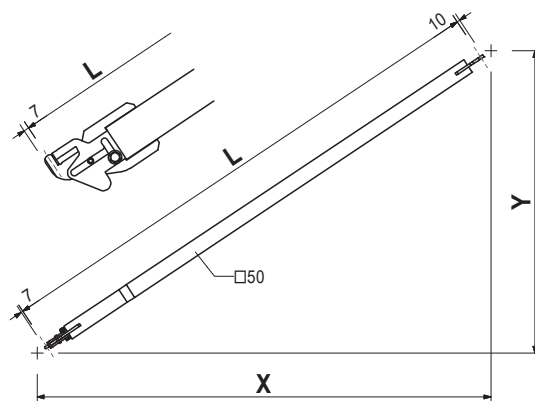
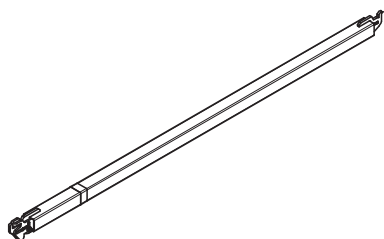

Article no. Weight kg

		<b>Node Braces UBK</b>		
Article no.	Weight kg	<b>L</b>	<b>X</b>	<b>Y</b>
424170	6.770	2190	750	2000
412926	6.980	2285	1000	2000
415354	5.210	1625	1250	1000
412765	7.250	2401	1250	2000
400981	5.700	1821	1500	1000
400973	6.570	2152	1500	1500
400572	7.590	2539	1500	2000
400985	6.780	2246	2000	1000
406630	7.500	2521	2000	1500
400573	8.380	2860	2000	2000
400989	7.930	2696	2500	1000
406624	8.530	2930	2500	1500
400574	9.300	3226	2500	2000
400993	9.120	3131	3000	1000
400575	10.300	3625	3000	2000

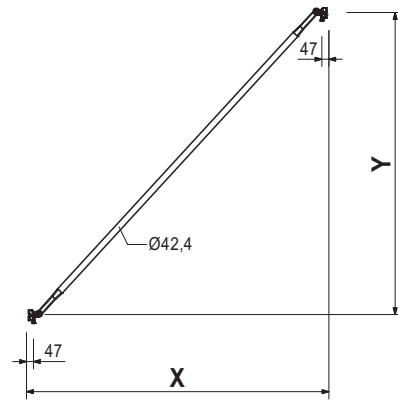
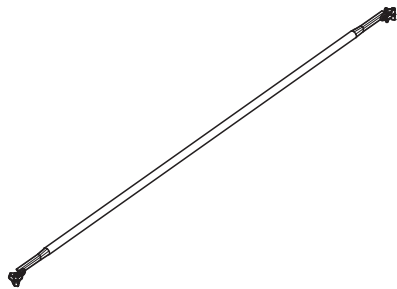

		<b>Node Braces UBK-2</b>		
Article no.	Weight kg	<b>L</b>	<b>X</b>	<b>Y</b>
133418	4.980	2190	750	2000
133421	5.130	2285	1000	2000
133424	3.900	1625	1250	1000
133427	5.320	2401	1250	2000
133430	4.240	1821	1500	1000
133433	4.840	2152	1500	1500
133436	5.550	2539	1500	2000
133439	4.990	2246	2000	1000
133442	5.490	2521	2000	1500
133445	6.100	2860	2000	2000
133448	5.790	2696	2500	1000
133451	6.210	2930	2500	1500
133454	6.740	3226	2500	2000
133457	6.620	3131	3000	1000
133460	6.980	3356	3000	1500
133463	7.440	3625	3000	2000

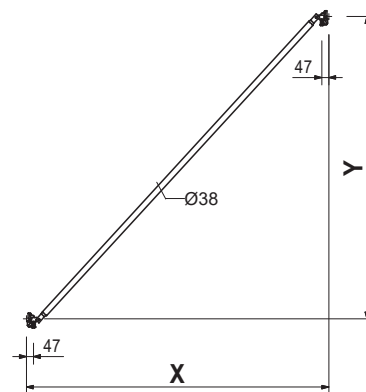
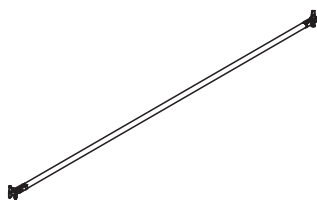

# PERI UP Flex Staircase 100, 125



Article no. Weight kg

114731	9.780	<b>Stair Stringers UA</b>
109219	15.800	<b>Stair Stringer UA 125/100</b>
		<b>Stair Stringer UA 250/200</b>

## Technical data

Permissible load 3.0 kN/m<sup>2</sup>.

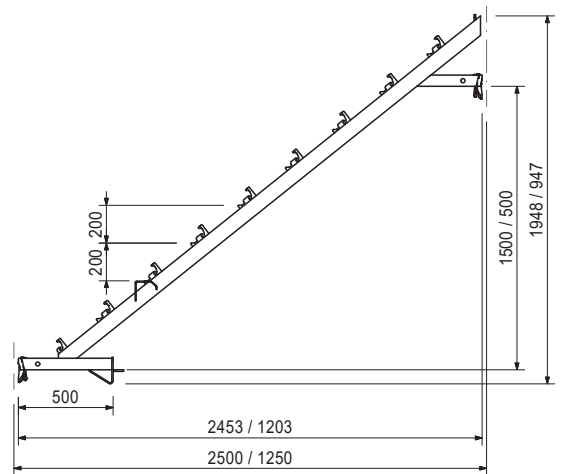
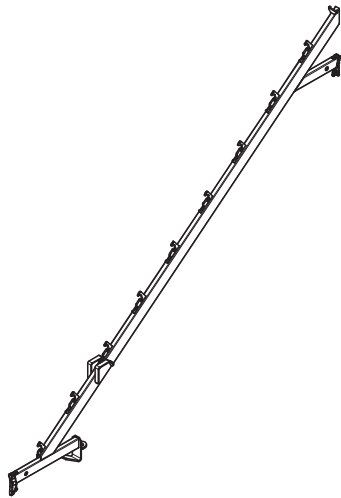

109198	7.390	<b>Steps UAR</b>
114179	9.250	<b>Step UAR 100</b>
		<b>Step UAR 125</b>

## Steps UAR

### Step UAR 100

### Step UAR 125

Step for Stair Stringer UA.

Non-slip due to perforated surface.

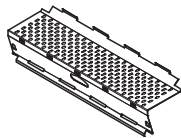

## Technical data

Permissible load 3.0 kN/m<sup>2</sup>.

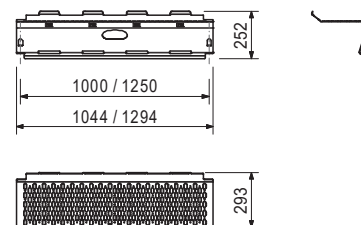

109208	5.610	<b>End Steps UAE</b>
114180	6.590	<b>End Step UAE 100</b>
		<b>End Step UAE 125</b>

## End Steps UAE

### End Step UAE 100

### End Step UAE 125

End Step for Stair Stringer UA. Secures all steps.

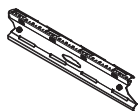

## Technical data

Permissible load 3.0 kN/m<sup>2</sup>.

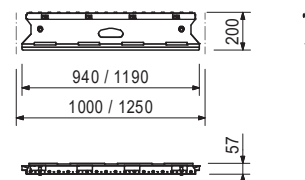

# PERI UP Flex Staircase 100, 125



Article no. Weight kg

Article no.	Weight kg	Steel Decks UDG
424124	3.880	<b>Steel Deck UDG 25 x 50</b>
432858	4.810	<b>Steel Deck UDG 25 x 67</b>
424121	5.260	<b>Steel Deck UDG 25 x 75</b>
424118	6.630	<b>Steel Deck UDG 25 x 100</b>
424115	8.010	<b>Steel Deck UDG 25 x 125</b>
424112	9.410	<b>Steel Deck UDG 25 x 150</b>
424109	12.200	<b>Steel Deck UDG 25 x 200</b>
423771	14.900	<b>Steel Deck UDG 25 x 250</b>
424915	17.700	<b>Steel Deck UDG 25 x 300</b>

Fit onto Horizontal Ledgers UH.

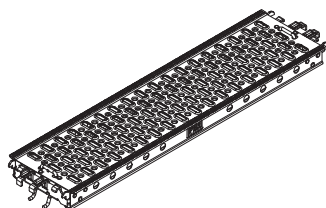

X	perm. p [kN/m <sup>2</sup> ]	max. p [kN/m <sup>2</sup> ]
500	6.0	40.0
670	6.0	40.0
750	6.0	40.0
1000	6.0	40.0
1250	6.0	28.4
1500	6.0	19.6
2000	6.0	10.9
2500	4.5	6.9
3000	3.0	4.7

### Note

Values correspond with EN 12811-1.  
max. p = max. possible surface load without deflection limitation.

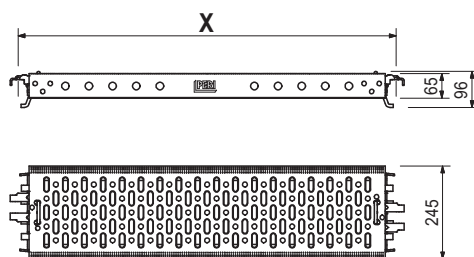

Article no.	Weight kg	Steel Decks UDG-2 25
132479	3.190	<b>Steel Deck UDG-2 25 x 50</b>
132483	3.960	<b>Steel Deck UDG-2 25 x 67</b>
132488	4.320	<b>Steel Deck UDG-2 25 x 75</b>
132492	5.450	<b>Steel Deck UDG-2 25 x 100</b>
132502	6.590	<b>Steel Deck UDG-2 25 x 125</b>
132505	7.730	<b>Steel Deck UDG-2 25 x 150</b>
132508	10.500	<b>Steel Deck UDG-2 25 x 200</b>
132511	12.900	<b>Steel Deck UDG-2 25 x 250</b>
132515	15.800	<b>Steel Deck UDG-2 25 x 300</b>

Length X: 500- 1500 with H of 45 mm  
Length X: 2000- 2500 with H of 60 mm  
Length X: 3000 with H of 70 mm

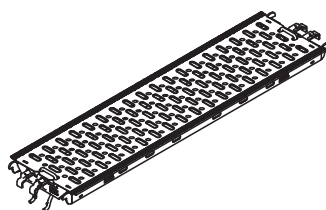

X	perm. p [kN/m <sup>2</sup> ]
500	6.0
670	6.0
750	6.0
1000	6.0
1250	6.0
1500	6.0
2000	6.0
2500	4.5
3000	3.0

### Note

Values correspond with EN 12811-1

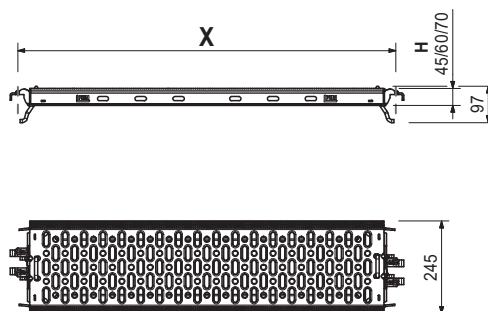

017010	1.400	<b>Swivel Coupling AF 48/48, galv.</b> For scaffold tubes Ø 48 mm.
--------	-------	---

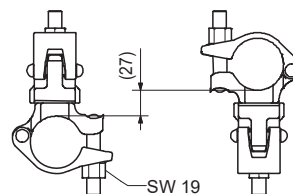
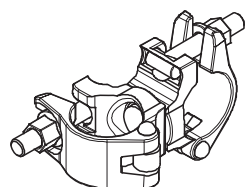

Article no. Weight kg

017020 1.120

## Standard Coupler RA 48/48, galv.

For scaffold tubes  $\varnothing$  48 mm.

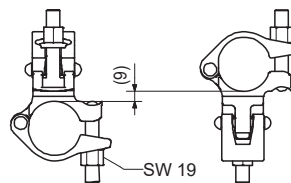
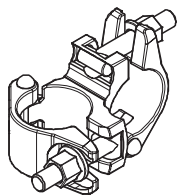

		<b>Steel scaffold tubes <math>\varnothing</math> 48.3 x 3.2</b>	<b>L</b>
026415	3.550	<b>Steel scaffold tube <math>\varnothing</math> 48.3 x 3.2, special length</b>	
026417	0.000	<b>Cutting costs for scaffold tubes</b>	
026411	3.550	<b>Steel scaffold tube <math>\varnothing</math> 48.3 x 3.2, L = 1.0 m</b>	1 000
026412	7.100	<b>Steel scaffold tube <math>\varnothing</math> 48.3 x 3.2, L = 2.0 m</b>	2 000
026413	10.650	<b>Steel scaffold tube <math>\varnothing</math> 48.3 x 3.2, L = 3.0 m</b>	3 000
026414	14.200	<b>Steel scaffold tube <math>\varnothing</math> 48.3 x 3.2, L = 4.0 m</b>	4 000
026419	17.750	<b>Steel scaffold tube <math>\varnothing</math> 48.3 x 3.2, L = 5.0 m</b>	5 000
026418	21.600	<b>Steel scaffold tube <math>\varnothing</math> 48.3 x 3.2, L = 6.0 m</b>	6 000

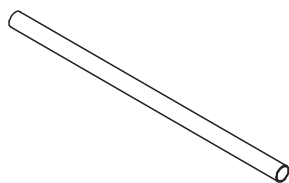

111053	0.059	<b>Locking pin <math>\varnothing</math> 48/57</b> As tension-proof connection of standards with a diameter of 48 up to 57 mm.
--------	-------	--

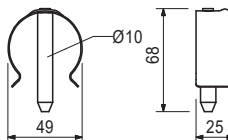

100719	0.060	<b>Bolt ISO 4014 M10 x 70-8.8</b> As tension-proof connection of standards at suspended scaffolds and formwork girders.
--------	-------	--

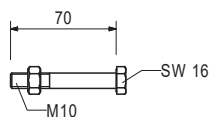
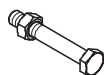

# PERI UP Flex Staircase 100, 125



Article no. Weight kg

Article no.	Weight kg		L
100088	1.920	<b>Wall Tie UWT</b>	488
100091	4.680	<b>Wall Tie UWT 45</b>	1 138
100093	5.870	<b>Wall Tie UWT 110</b>	1 438
102951	7.060	<b>Wall Tie UWT 140</b>	1 738
102954	9.050	<b>Wall Tie UWT 170</b>	2 238
102957	11.000	<b>Wall Tie UWT 270</b>	2 738

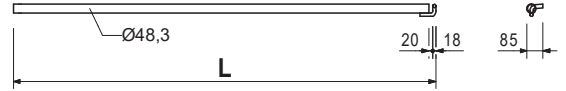
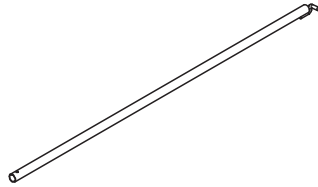

Article no.	Weight kg		Note
100693	0.169	<b>Eyebolts UFE</b>	With marking for screw-in depth.
100694	0.190	<b>Eyebolt UFE 12/90</b>	
100695	0.250	<b>Eyebolt UFE 12/120</b>	
		<b>Eyebolt UFE 12/190</b>	
For assembly of the Wall Tie UWT. Required Expanding Dowel UFI 14.			

Article no.	Weight kg	
100696	0.007	<b>Expanding Dowel UFI</b>
100697	0.009	<b>Expanding Dowel UFI 14/70</b>
100698	0.010	<b>Expanding Dowel UFI 14/100</b>
		<b>Expanding Dowel UFI 14/135</b>

Article no.	Weight kg		Note
100242	4.570	<b>Base Spindle UJB 38-80/55</b>	With captive yellow quick jack nut.

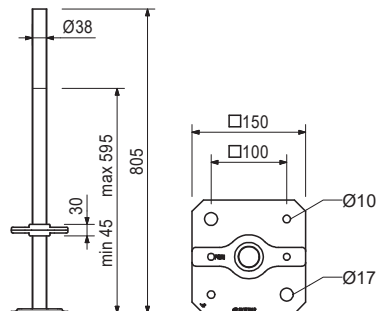
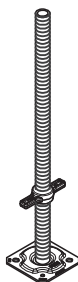

Article no.	Weight kg	Accessories
100863	1.020	<b>Spindle Locking UJS</b>





The optimal system for all projects and every requirement



Wall formwork



Column formwork



Slab formwork



Climbing systems

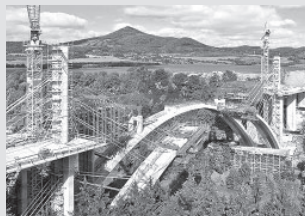

Bridge formwork



Tunnel formwork



Shoring



Working scaffolds



Working scaffolds facade



Working scaffolds industry



Means of access



Safety scaffolds



Safety systems

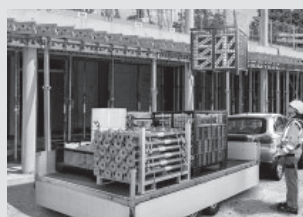

System-independent accessories



Services



**PERI SE**  
**Formwork Scaffolding Engineering**  
 Rudolf-Diesel-Strasse 19  
 89264 Weissenhorn  
 Germany  
 Telephone +49 (0)7309.950-0  
 Fax +49 (0)7309.951-0  
 info@peri.de  
 www.peri.com



**PERI Australia Pty Ltd**  
**Formwork Scaffolding Engineering**  
 116 Glendenning Rd  
 Glendenning NSW 2761  
 Australia  
 Telephone +61 (2) 8805 2300  
 Fax +61 (2) 9675 7277  
 info@peri.com.au  
 www.peri.com.au